

DCDH-Series Mini DC Motors – Upto 400Watts

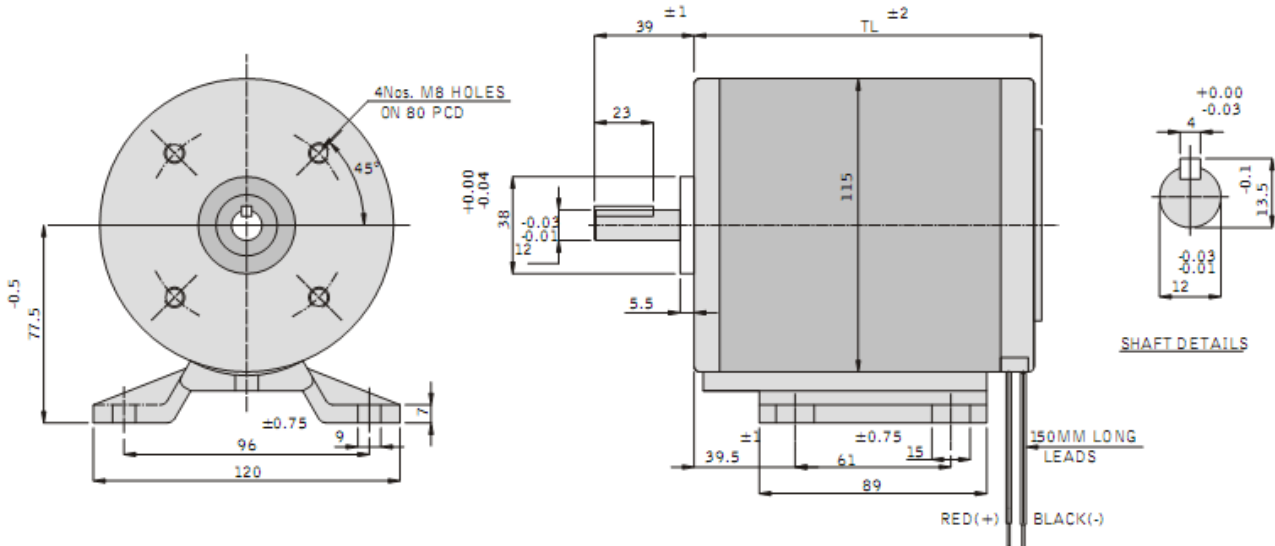

SPECIFICATIONS

H.P./Watts	Frame Size	Volts		Current (Amps)		TL	Torque (Kg.cm)	Mounting	Type	Ins. Class	Protection	Duty	Weight (kg)
		V1	V2	I1	I2								
1500 RPM MOTORS													
0.12 /90	DH-2	12	24	10.0	5.0	116	6	Foot/Face	TENV	F	IP-44	S1	3.4
0.16/120	DH-3	12	24	14.0	7.0	136	8	Foot/Face	TENV	F	IP-44	S1	4.3
0.34/250	DH-4	12	24	26.0	13.0	156	16	Foot/Face	TENV	F	IP-44	S1	5.8
3000 RPM MOTORS													
0.25/185	DH-2	12	24	20.0	10.0	116	6	Foot/Face	TENV	F	IP-44	S1	3.4
0.34/250	DH-3	12	24	28.0	13.0	136	8	Foot/Face	TENV	F	IP-44	S1	4.3
0.54/400	DH-4	12	24	42.0	21.0	156	13	Foot/Face	TENV	F	IP-44	S1	5.8

*Base plate available only on request.