

DCCT-Series Mini DC Motors – Upto 120Watts

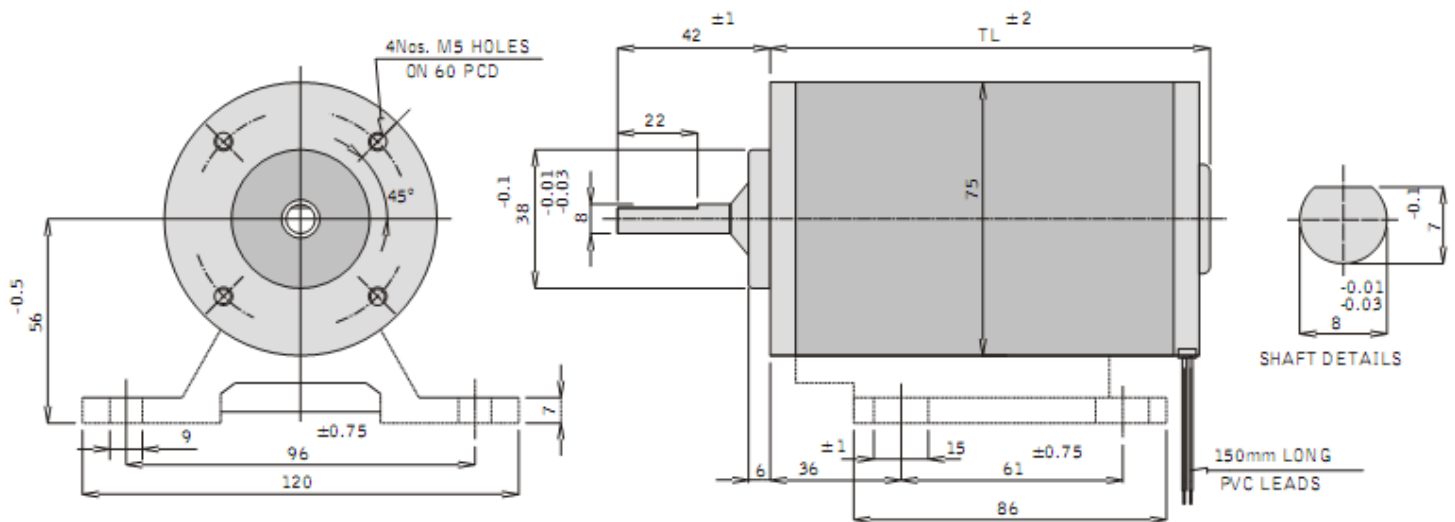

SPECIFICATIONS

H.P./Watts	Frame Size	Volts		Current (Amps)		TL	Torque (Kg.cm)	Mounting	Type	Ins. Class	Protection	Duty	Weight (kgs)
		V1	V2	I1	I2								
1500 RPM MOTORS													
0.05 / 40	CT-1	12	24	4.5	2.2	121	2.5	Foot/Face	TENV	F	IP-44	S1	1.7
0.08 / 60	CT-2	12	24	6.5	3.5	151	4.0	Foot/Face	TENV	F	IP-44	S1	2.2
3000 RPM MOTORS													
0.1 / 80	CT-1	12	24	9.0	4.5	121	2.5	Foot/Face	TENV	F	IP-44	S1	1.7
0.16/120	CT-2	12	24	13.0	7.0	151	4.0	Foot/Face	TENV	F	IP-44	S1	2.2

*Base plate available only on request. Also available in 36 & 48 Volts