

DC180V-Series DC Motors – (Industrial) Upto 2250Watts



**M30, M3, M7
FOOT MOUNTING**



**M30, M3, M7
B5 FLANGE MOUNTING
(Foot Optional)**



**V1, V2, V3
FOOT MOUNTING**



**V1, V2, V3
B5 FLANGE MOUNTING
(Foot Optional)**

SPECIFICATIONS

HP	Watts	Frame Size		IEC Frame		Volts	Amps	Torque (Kg-cm)	Type	Protection	Ins. Class	Weight (Kgs.)
		FOOT Mounting	Flg./Face Mounting	B5	B14							
1500 RPM MOTORS												
0.10	75	S2N-T	S2N-F	-	-	180	0.5	5	SPDP	IP-21	B	5
0.25	180	M30-T	M30-L	M30-71	M30-71	180	1.3	12	TEFC	IP-44	B	9
0.5	370	M3-T	M3-L	M3-71	M3-71	180	2.6	24	TEFC	IP-44	B	11
1.0	750	M7-T	M7-L	M7-80	-	180	5.2	48	TEFC	IP-44	B	14
2.0	1500	V2-T	V2-L	-	-	180	11.0	96	SPDP	IP-21	F	23
3.0	2250	V3-T	V3-L	V3-100	-	180	16.7	143	SPDP	IP-21	F	30
3000 RPM MOTORS												
0.16	120	S2N-T	S2N-F	-	-	180	0.9	3.5	SPDP	IP-21	B	5
0.25	180	M30-T	M30-L	M30-71	M30-71	180	1.3	6	TEFC	IP-44	B	9
0.5	370	M30-T	M30-L	M30-71	M30-71	180	2.6	12	TEFC	IP-44	B	9
1.0	750	M5-T	M5-L	M5-71	-	180	5.2	24	TEFC	IP-44	B	12
1.5	1125	M7-T	M7-L	M7-80	-	180	8.5	36	TEFC	IP-44	B	14
2.0	1500	V1-T	V1-L	-	-	180	11.0	48	SPDP	IP-21	F	18
3.0	2250	V2-T	V2-L	-	-	180	16.7	72	SPDP	IP-21	F	23

Flange Mounted PMDC Motors (IEC B5 Frame)

Dimensions: DC180V Industrial – Series DC Motors

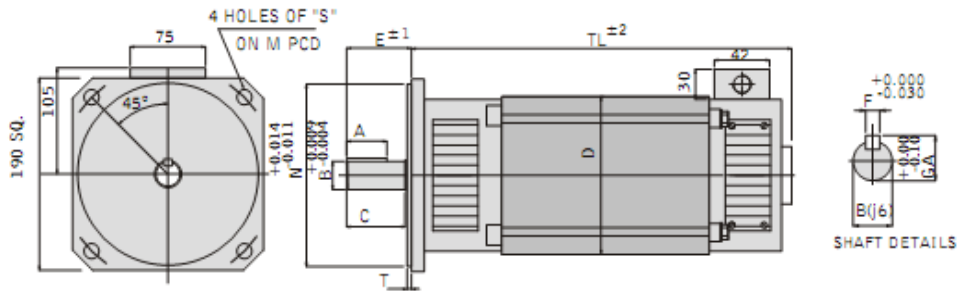

(V1-L, V2-L, V3-100B5)

Foot Mounted PMDC Motors

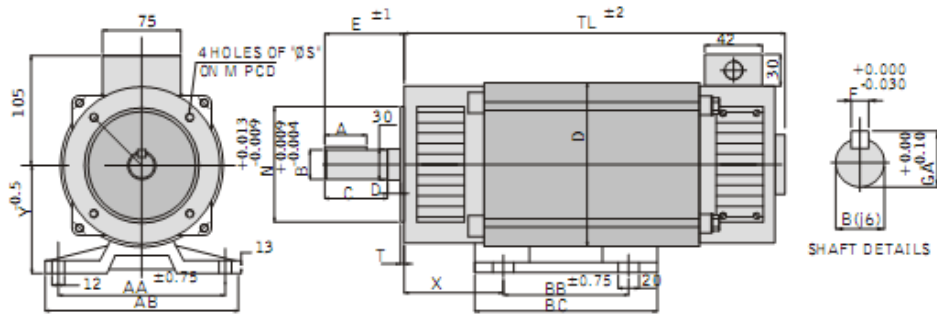

(S2N-F & S2N-T, V1-T, V2-T, V3-T)

DIMENSIONS

Frame Size	A	∅B	C	D	E	F	GA	T	LA	∅N	M	S	AA	AB	BB	BC	∅D	X	Y	TL
S2N-F/S2N-T	23	11	25	-	30	4	12.5	5	-	38	72.5	M4	96	120	61	89	92	42.5	64.5	174
V1-T	34	19	41	3.5	48	6	21.5	3.5	-	110	130	M8	160	185	140	175	156	96.5	100	298
V1-L	34	19	37	-	40	6	21.5	4.0	12	180	215	15	-	-	-	-	156	-	-	310
V2-T	40	24	50	12.5	66	8	27	3.5	-	110	130	M8	160	185	140	175	156	96.5	100	373
V2-L	40	24	50	-	54	8	27	4.0	12	180	215	15	-	-	-	-	156	-	-	385
V3-T	40	28	60	12.5	76	8	31	3.5	-	110	130	M8	160	185	140	175	156	96.5	100	448
V3-100B5	40	28	60	-	64	8	31	4.0	12	180	215	15	-	-	-	-	156	-	-	460

(T – Foot Mount) & (L&F – Face Mount)

Foot & Face Mounted PMDC Motors (IEC B14 Frame)

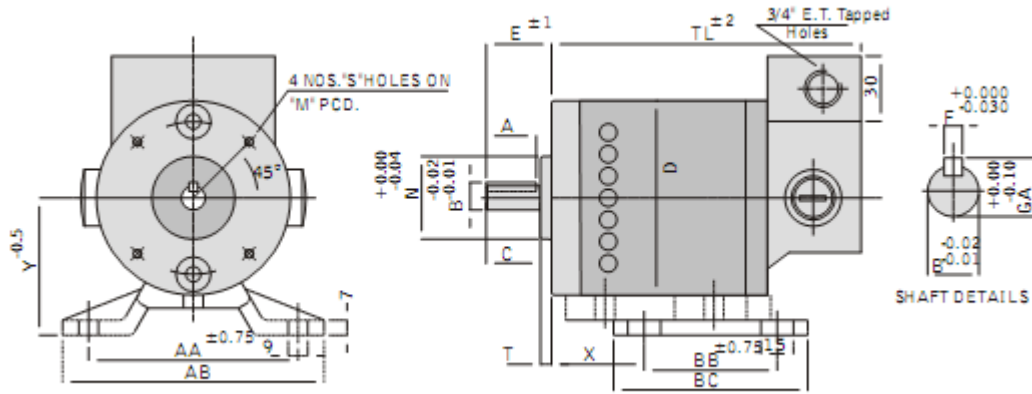

**(M30-L, M3-L, M5-L & M7-L)
Face Dimensions**

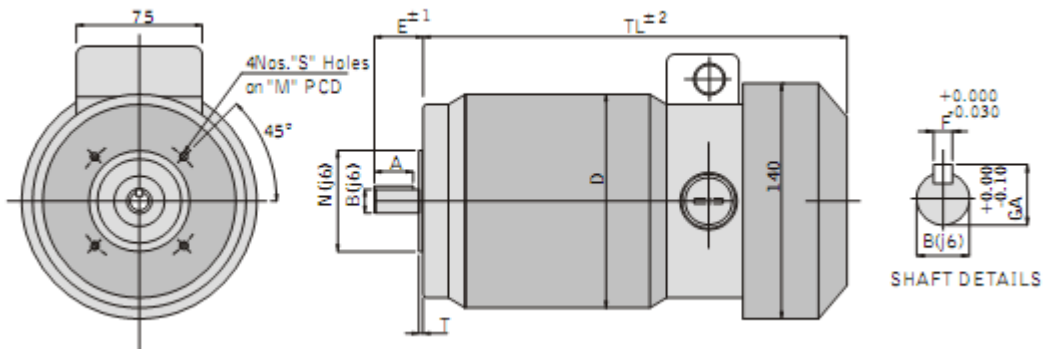

(M30-71B14, M3-71B14) IEC Flange

Flange Mounted PMDC Motors (IEC B5 Frame)

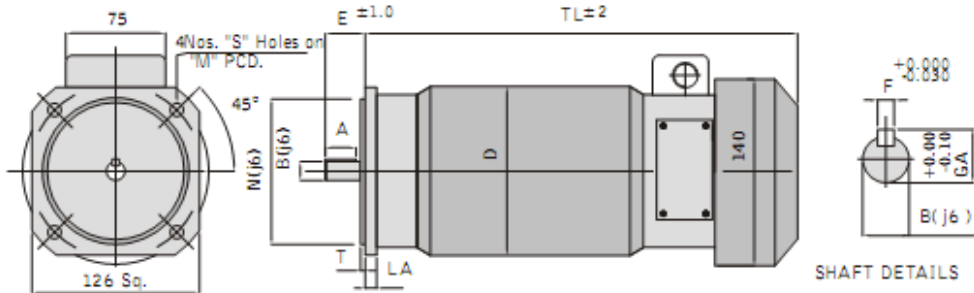

(M30-71B5, M3-71B5, M5-71B5, M7-80B5) IEC Flange

Foot Mounted PMDC Motors

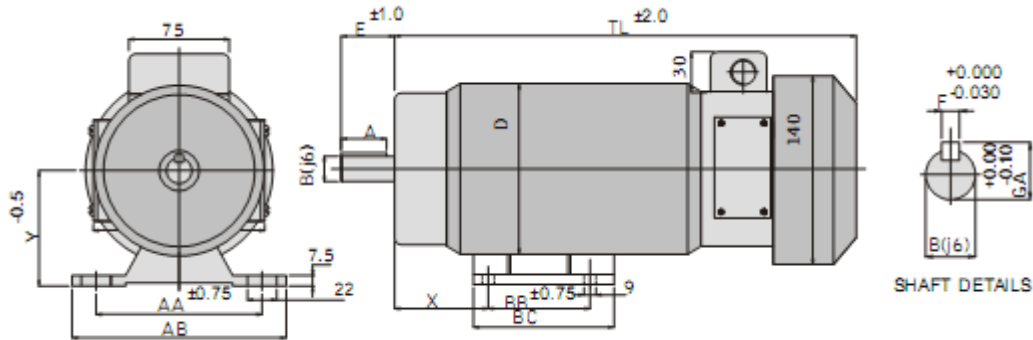

(M30-T, M3-T, M5-T, M7-T) Foot Mounting

DIMENSIONS																				
Frame Size	A	∅B	C	D	E	F	GA	T	LA	∅N	M	S	AA	AB	BB	BC	∅D	X	Y	TL
M30-T/M30-L	34	19	-	-	40	6	21.5	3.5	8.5	110	130	10	124	160	76	105	127	60	86	237
M30-71B5	23	14	-	-	30	5	16.0	3.5	8.5	110	130	10	-	-	-	-	127	-	-	237
M30-71B14	23	14	-	-	30	5	16.0	2.5	-	70	85	M6	-	-	-	-	127	-	-	213
M3-T / M3-L	34	19	-	-	40	6	21.5	3.5	8.5	110	130	-	124	160	76	105	127	70	86	257
M3-71B5	23	14	-	-	30	5	16.0	3.5	8.5	110	130	10	-	-	-	-	127	-	-	257
M3-71B14	23	14	-	-	30	5	16.0	2.5	-	70	85	M6	-	-	-	-	127	-	-	233
M5-T / M5-L	34	19	-	-	40	6	21.5	3.5	8.5	110	130	-	124	160	76	105	127	70	86	297
M7-T / M7-L	34	19	-	-	40	6	21.5	3.5	8.5	110	130	10	124	160	76	105	127	70	86	345
M7-80B5	34	19	-	-	40	6	21.5	3.5	12	130	165	12	-	-	-	-	127	-	-	345