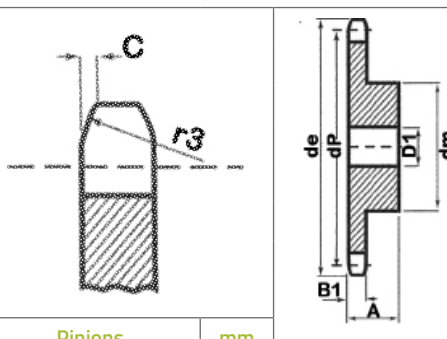
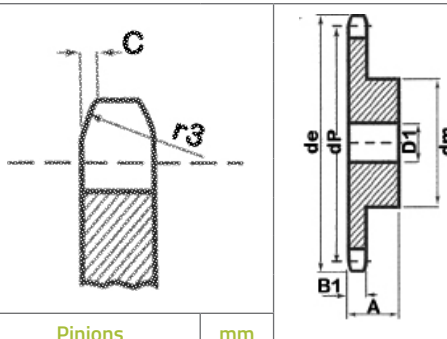
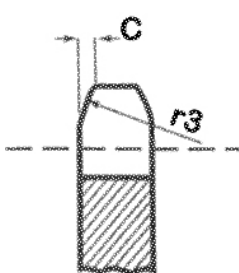
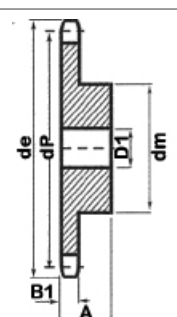

| 06B-1 Sprocket | | Teeth | de | dp | Simplex | | | |
|-----------------|-----------|-------|------|-------|---------|----|----|---------|
| | | | | | dm | D1 | A | App. Kg |
| | | 13 | 43.5 | 39.8 | 28 | 8 | 25 | 0.11 |
| | | 15 | 49.5 | 45.81 | 34 | 8 | 25 | 0.14 |
| | | 17 | 55.5 | 51.83 | 40 | 10 | 28 | 0.20 |
| | | 19 | 61.6 | 57.87 | 45 | 10 | 28 | 0.25 |
| | | 21 | 67.6 | 63.91 | 48 | 12 | 28 | 0.36 |
| | | 23 | 73.7 | 69.95 | 52 | 12 | 28 | 0.39 |
| | | 25 | 79.7 | 76 | 57 | 12 | 28 | 0.41 |
| | | 27 | 85.7 | 82.04 | 60 | 12 | 28 | 0.44 |
| | | 30 | 94.8 | 91.12 | 60 | 12 | 28 | 0.48 |
| | | 38 | 119 | 115.3 | 70 | 16 | 30 | 0.77 |
| Pinions | mm | | | | | | | |
| Tooth Radius r3 | | | | | | | | |
| Radius Width C | | | | | | | | |
| Tooth Width B1 | 5.3 | | | | | | | |
| Tooth Width b1 | | | | | | | | |
| Chain | mm | | | | | | | |
| Pitch | 9.53 | | | | | | | |
| Inside | 5.72 | | | | | | | |
| Roller ϕ | 6.35 | | | | | | | |

| 08B-1 Sprocket | | Teeth | de | dp | Simplex | | | |
|-----------------|-----------|-------|-------|-------|---------|----|----|---------|
| | | | | | dm | D1 | A | App. Kg |
| | | 13 | 57.9 | 53.06 | 37 | 10 | 28 | 0.25 |
| | | 15 | 65.9 | 61.09 | 45 | 10 | 28 | 0.33 |
| | | 17 | 74 | 69.11 | 52 | 12 | 28 | 0.51 |
| | | 19 | 82 | 77.16 | 60 | 12 | 28 | 0.65 |
| | | 21 | 90.1 | 85.22 | 68 | 14 | 28 | 0.82 |
| | | 23 | 98.1 | 93.27 | 70 | 14 | 28 | 1.05 |
| | | 25 | 106.2 | 101.3 | 70 | 14 | 28 | 1.13 |
| | | 27 | 114.2 | 109.4 | 70 | 16 | 30 | 1.19 |
| | | 30 | 126.3 | 121.5 | 80 | 16 | 30 | 1.36 |
| | | 38 | 158.6 | 153.8 | 90 | 16 | 35 | 1.78 |
| Pinions | mm | | | | | | | |
| Tooth Radius r3 | | | | | | | | |
| Radius Width C | | | | | | | | |
| Tooth Width B1 | 7.2 | | | | | | | |
| Tooth Width b1 | | | | | | | | |
| Chain | mm | | | | | | | |
| Pitch | 12.7 | | | | | | | |
| Inside | 7.75 | | | | | | | |
| Roller ϕ | 8.51 | | | | | | | |

| 10B-1 Sprocket | | Teeth | de | dp | Simplex | | | | |
|---|-----------------|-----------|----|-------|---------|-----|----|---------|------|
| | | | | | dm | D1 | A | App. Kg | |
|  | Pinions | mm | 13 | 87.8 | 79.59 | 58 | 16 | 35 | 0.75 |
| | Tooth Radius r3 | | 15 | 99.8 | 91.63 | 70 | 16 | 35 | 1.14 |
| | Radius Width C | | 17 | 111.9 | 103.7 | 80 | 16 | 35 | 1.46 |
| | Tooth Width B1 | 9.1 | 19 | 123.9 | 115.8 | 80 | 16 | 35 | 1.78 |
| | Tooth Width b1 | | 21 | 136 | 127.8 | 90 | 20 | 40 | 2.27 |
| | | | 23 | 148.1 | 139.9 | 90 | 20 | 40 | 2.49 |
| | | | 25 | 160.2 | 152 | 90 | 20 | 40 | 2.78 |
| | | | 27 | 172.3 | 164.1 | 95 | 20 | 40 | 3.05 |
| | | | 30 | 190.4 | 182.3 | 95 | 20 | 40 | 3.44 |
| | | | 38 | 238.9 | 230.1 | 100 | 25 | 40 | 4.92 |
| Chain | mm | | | | | | | | |
| Pitch | 5.88 | | | | | | | | |
| Inside | 9.65 | | | | | | | | |
| Roller ø | 10.2 | | | | | | | | |

| 12B-1 Sprocket | | Teeth | de | dp | Simplex | | | | |
|---|-----------------|-----------|----|-------|---------|-----|----|---------|------|
| | | | | | dm | D1 | A | App. Kg | |
|  | Pinions | mm | 13 | 87.8 | 79.59 | 58 | 16 | 35 | 0.75 |
| | Tooth Radius r3 | | 15 | 99.8 | 91.63 | 70 | 16 | 35 | 1.14 |
| | Radius Width C | | 17 | 111.9 | 103.7 | 80 | 16 | 35 | 1.46 |
| | Tooth Width B1 | 11.1 | 19 | 123.9 | 115.8 | 80 | 16 | 35 | 1.78 |
| | Tooth Width b1 | | 21 | 136 | 127.8 | 90 | 20 | 40 | 2.27 |
| | | | 23 | 148.1 | 139.9 | 90 | 20 | 40 | 2.49 |
| | | | 25 | 160.2 | 152 | 90 | 20 | 40 | 2.78 |
| | | | 27 | 172.3 | 164.1 | 95 | 20 | 40 | 3.05 |
| | | | 30 | 190.4 | 182.3 | 95 | 20 | 40 | 3.44 |
| | | | 38 | 238.9 | 230.1 | 100 | 25 | 40 | 4.92 |
| Chain | mm | | | | | | | | |
| Pitch | 19.05 | | | | | | | | |
| Inside | 11.68 | | | | | | | | |
| Roller ø | 12.07 | | | | | | | | |

| 16B-1 Sprocket | | Teeth | de | dp | Simplex | | | | | | | | | | | | |
|--|---|---------|-------|-----------------|---------|----------------|----|----------------|-------|----------------|--|--|--|--|--|--|--|
| | | | | | dm | D1 | A | App. Kg | | | | | | | | | |
|  |  | 13 | 117.7 | 106.1 | 78 | 16 | 40 | 1.94 | | | | | | | | | |
| | | 15 | 133.7 | 122.2 | 92 | 16 | 40 | 2.59 | | | | | | | | | |
| | | 17 | 149.8 | 138.2 | 100 | 20 | 45 | 3.18 | | | | | | | | | |
| | | 19 | 165.9 | 154.4 | 100 | 20 | 45 | 3.86 | | | | | | | | | |
| | | 21 | 182 | 170.4 | 110 | 20 | 50 | 4.54 | | | | | | | | | |
| | | 23 | 198.1 | 186.5 | 110 | 20 | 50 | 5.08 | | | | | | | | | |
| | | 25 | 214.2 | 202.7 | 110 | 20 | 50 | 5.76 | | | | | | | | | |
| | | 27 | 230.4 | 218.8 | 120 | 20 | 50 | 7.53 | | | | | | | | | |
| | | 30 | 254.6 | 243 | 120 | 20 | 50 | 8.26 | | | | | | | | | |
| | | 38 | 319.2 | 307.6 | 120 | 25 | 50 | 11.12 | | | | | | | | | |
| <table border="1"> <thead> <tr> <th>Pinions</th> <th>mm</th> </tr> </thead> <tbody> <tr> <td>Tooth Radius r3</td> <td></td> </tr> <tr> <td>Radius Width C</td> <td></td> </tr> <tr> <td>Tooth Width B1</td> <td>16.2</td> </tr> <tr> <td>Tooth Width b1</td> <td></td> </tr> </tbody> </table> | | Pinions | mm | Tooth Radius r3 | | Radius Width C | | Tooth Width B1 | 16.2 | Tooth Width b1 | | | | | | | |
| Pinions | mm | | | | | | | | | | | | | | | | |
| Tooth Radius r3 | | | | | | | | | | | | | | | | | |
| Radius Width C | | | | | | | | | | | | | | | | | |
| Tooth Width B1 | 16.2 | | | | | | | | | | | | | | | | |
| Tooth Width b1 | | | | | | | | | | | | | | | | | |
| <table border="1"> <thead> <tr> <th>Chain</th> <th>mm</th> </tr> </thead> <tbody> <tr> <td>Pitch</td> <td>25.4</td> </tr> <tr> <td>Inside</td> <td>17</td> </tr> <tr> <td>Roller ϕ</td> <td>15.88</td> </tr> </tbody> </table> | | Chain | mm | Pitch | 25.4 | Inside | 17 | Roller ϕ | 15.88 | | | | | | | | |
| Chain | mm | | | | | | | | | | | | | | | | |
| Pitch | 25.4 | | | | | | | | | | | | | | | | |
| Inside | 17 | | | | | | | | | | | | | | | | |
| Roller ϕ | 15.88 | | | | | | | | | | | | | | | | |

