

Specialised Air Motors and Transmission

SAMT

Specialised Air Motors and Transmission

TONSON Australia (SAMT) Pty Ltd.
Factory 19 / 5 Lyn Parade PRESTONS NSW 2170
PH: 02 9607 4100 FAX: 02 9607 4200
www.tonson-motor.com.au

Asynchronous three-phase motors LEX and LEN Series IE2 Efficiency



FORME COSTRUTTIVE - CONSTRUCTION SHAPES

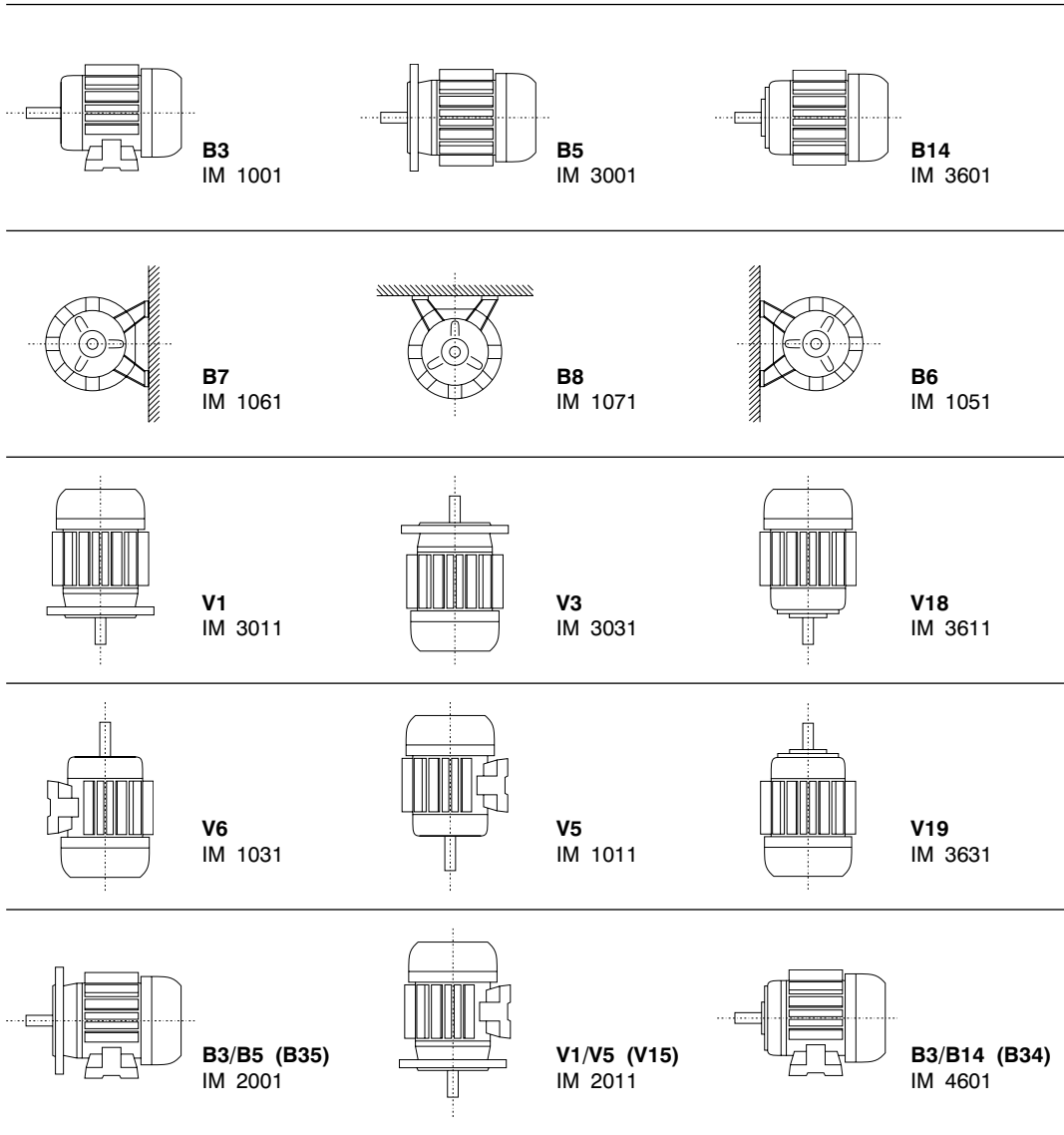

PRESENTAZIONE

La Direttiva comunitaria N° 94/9/EC ATEX identifica le seguenti aree pericolose:

- Area con presenza di **GAS: Zona 0, Zona 1 e Zona 2**
- Area con presenza di **POLVERI (Dust): Zona 20, Zona 21 e Zona 22**

I nostri motori serie LEX e LEN sono così identificati e abilitati per essere installati come segue:

Serie LEX

- Modo di protezione: **Ex nA II T3 IP65 II 3D; Ex tD A21 IP65 T135°C II 2D**
- Aree di utilizzo: **Zona 2, Zona 21 e Zona 22**
- Omologazione: certificato **N. ICEPI 07 ATEX 03C009**
- Ente: Istituto **ICEPI** di Piacenza-Italy, organismo notificato **N. 0066**

Serie LEN

- Modo di protezione: **Ex tD A22 IP65 T155°C II 3D**
- Aree di utilizzo: **Zona 22**
- Omologazione: autocertificato secondo Direttiva ATEX

CARATTERISTICHE GENERALI

I nostri motori **serie LEX e LEN** sono progettati e costruiti per rispettare le condizioni di utilizzo in ambienti definiti pericolosi Secondo Direttiva ATEX, offrendo il massimo della sicurezza e affidabilità d'impiego.

CARATTERISTICHE COSTRUTTIVE

Tutti i motori serie LEX e LEN hanno le seguenti caratteristiche costruttive:

- Carcasse: fusione in ghisa
- Scudi: fusione in ghisa
- Scatola morsettiera: fusione in ghisa, con possibilità di rotazione di 90° in 90°
- Ventola: in polietilene dalla grandezza 80 alla grandezza 280; in alluminio per le grandezze 315 e 355
- Copriventola: in acciaio stampato per tutte le grandezze

SPECIFICHE STANDARD

Tutti i motori sono costruiti con il seguente grado di protezione meccanica:

- Motori **serie LEX**: grado di protezione meccanica IP65
- Motori **serie LEN**: grado di protezione meccanica IP55

I motori serie LEX e LEN sono chiusi con ventilazione esterna e disponibili nelle seguenti forme costruttive:

- dalla grandezza 80 alla grandezza 280: B3 (IM 1001); B5 (IM 3001): B3/B5 (IM 2001) e V1 (IM 3031)
- per le grandezze 315 e 355: B3 (IM 1001); B3/B5 (IM 2001) e V1 (IM 3031)

La potenza nominale indicata in targa si intende per servizio continuo S1. Il voltaggio Standard di v. 400 con frequenza Hz50. La tolleranza sulla tensione è di $\pm 5\%$: voltaggi oltre questi valori danneggiano l'avvolgimento. I motori **serie LEX e LEN** possono operare con temperatura ambiente massima di 40°C e con altitudine massima di 1000 m s.l.m.

La classe di isolamento è **F** con sovratemperatura dell'avvolgimento della classe **B**.

Dalla grandezza 160 alla grandezza 355, gli avvolgimenti sono provvisti di protettori termici PTC collegati in scatola morsettiera principale con morsetti separati.

Il lamierino magnetico è al silicio isolato a basse perdite. Il livello di vibrazione è molto basso: la maggior parte di motori hanno vibrazioni inferiori a 1 mm/sec.

CUSCINETTI

Tutti i motori **serie LEX e LEN** sono equipaggiati con cuscinetti SKF o NSK, con precarico sul lato comando.

Fino alla grandezza 132, i cuscinetti sono ZZ; dalla grandezza 160 in poi sono aperti, con gioco radiale C3 e la lubrificazione avviene mediante ingrassatori.

NORME DI RIFERIMENTO

I motori **serie LEX e LEN** sono costruiti rispettando le seguenti norme:

- IEC EN 60034-1 Macchine elettriche rotanti - Caratteristiche nominali e di funzionamento
- IEC EN 60034-5 gradi di protezione degli involucri delle macchine elettriche (Codice IP) - Classificazione
- IEC EN 60072-1 Dimensioni esterne e tolleranze costruttive delle macchine elettriche rotanti
- EN 60079-0:2006 Costruzioni elettriche per atmosfere esplosive per la presenza di gas - Regole generali
- EN 60079-15:2005 Costruzione elettrica per atmosfere potenzialmente esplosive - Modo di protezione "n"
- EN 61241-1:2006 Costruzioni elettriche destinate ad essere utilizzate in presenza di polveri combustibili - Protezione mediante custodie "tD"
- EN 61241-0:2004 Costruzioni elettriche destinate ad essere utilizzate in presenza di polveri combustibili - Regole generali

La società **SAMT** srl si riserva il diritto di apportare, in qualunque momento e senza preavviso, eventuali modifiche allo scopo di migliorare i propri prodotti.

INTRODUCTION

The european directive N. 94/9/EC ATEX identify the following hazardous areas:

- Area with presence of **GAS: Zone 0, Zone 1 and Zone 2**
- Area with presence of **DUST: zone 20, Zone 21 and Zone 22**

Our **LEX** and **LEN** series motors are identified and qualified to be installed as follows:

LEX series

- Type of enclosure: **Ex nA II T3 IP 65 II 3D; Ex tD A21 IP 65 T 135°C II 2D**
- Areas of use: **Zone 2, Zone 21 and Zone 22**
- Certification: **N. ICEPI 07 ATEX 03C009**
- Authority: **ICEPI** institute of Piacenza - Italy, notified body **N. 0066**

LEN series

- Type of enclosure: **Ex tD A22 IP65 T 155°C II 3D**
- Areas of use: **Zone 22**
- Certification: authocertified according to ATEX standard

GENERAL CHARACTERISTICS

Our **LEX** and **LEN** series motors are designed and manufactured to respect the service conditions in the environments defined dangerous by the ATEX normative, offering the maximum safety and the reliability.

CONSTRUCTION CHARACTERISTICS

All the **LEX** and **LEN** series motors have the following constructive characteristics:

- Housing: cast iron
- Shields: cast iron
- Terminal box: cast iron, it can be rotated by 90 degrees
- Fan in polyethylene from 80 to 280 frame size; in aluminium for 315 and 355 frame size
- Fan cover: pressed steel for all sizes

STANDARD SPECIFICATIONS

All motors are designed with the following mechanical degree of protection:

- **LEX series** motors: mechanical degree of protection IP 65
- **LEN series** motors: mechanical degree of protection IP 55

LEX and **LEN** series motors are TEFC and available with the following construction shapes:

- From 80 to 280: B3 (IM 1001); B5 (IM 3001); B3/B5 (IM 2001) and V1 (IM 3031)
- Frame size 315 and 355: B3 (IM 1001); B/B5 (IM 2001) and V1 (IM 3031)

The rated output indicated on the nameplate is for S1 continuous duty.

The standard voltage is V. 400 Hz 50.

The tolerance on the tension is $\pm 5\%$: voltages applied beyond this tolerance may cause damage to the winding.

The **LEX** and **LEN** series motors can work with maximum ambient temperature of 40°C and altitudes up to 1000 metres above the sea level.

The insulation class is **F**, class **B** temperature rise limit.

From frame size 160 up to 355 the windings are equipped with PTC thermistors connected in the main terminal box through separate terminals.

The rotor and stator laminations are produced from low loss double insulated silicon electrical steel. Vibration level is very low; most motors have vibrations levels of less than 1mm/sec.

BEARINGS

All the **LEX** and **LEN** series motors have SKF or NSK bearings which are preloaded on drive end.

Up to frame size 132 the bearings are ZZ, from frame size 160 upwards they have C3 clearances and lubrication is performed through grease release.

STANDARDS

- IEC EN 60034-1 Rotating electrical machines - Rating performances
- IEC EN 60034-5 degrees of protection provided by the integral design of rotating electrical machines - (IP Code) - Classification
- IEC EN 60072-1 Dimensions and output series for rotating electrical machines
- EN 60079-0:2006 Electrical apparatus for explosive atmospheres - General requirements
- EN 60079-15:2005 Electrical apparatus for potentially explosive atmospheres - Type of protection "n"
- EN 61241-1:2006 Electrical apparatus for use in the presence of combustible dust - Protection by enclosures "tD"
- EN 61241-0:2004 Electrical apparatus for use in the presence of combustible dust - General requirements

SAMT reserved the right to make at any time without notice, with the intention to maintain their products to the highest standard.

DATI ELETTRICI - MOTORI TRIFASE Serie LEX e LEN IE2
RATED DATA - THREE PHASE MOTORS - LEX and LEN Series IE2
POLI 2

2 Pole 3000 RPM Synchronous Speed 50Hz

TIPO TYPE	POTENZA OUTPUT KW	GIRI/min. r.p.m.	CORRENTE A VUOTO NO LOAD CURRENT V 400 A	CORRENTE FULL LOAD CURRENT			Ia/In Ia/In	RENDIMENTO EFFICIENCY			FATTORE DI POTENZA POWER FACTOR			RATED TORQUE Nm	Ca/Cn Ma/Mn	Cm/Cn Mk/Mn	Mom. In. J (Kg ^m)	RUMOR NOISE LEVEL 1 m dB (A)	MASSA MASS Kg.
				380V A	400V A	415V A		100%	75%	50%	η	100%	cos γ 75%						
LEX-LEN 801-2	0.75	2850	0.8	1.8	1.7	1.6	6.8	77.4	78.9	78.6	0.83	0.78	0.71	2.5	2.3	2.4	0.0008	58	18
LEX-LEN 802-2	1.1	2840	1.2	2.5	2.4	2.3	7.3	79.6	81.0	80.8	0.83	0.79	0.70	3.7	2.3	2.5	0.0009	56	20
LEX-LEN 90S-2	1.5	2875	1.4	3.3	3.2	3.1	7.6	81.3	81.8	80.6	0.84	0.80	0.71	5.0	2.4	2.6	0.0012	64	26
LEX-LEN 90L-2	2.2	2880	1.8	4.7	4.5	4.3	7.8	83.2	84.1	83.5	0.85	0.81	0.71	7.3	2.3	2.6	0.0014	68	30
LEX-LEN 100L-2	3	2880	2.1	6.2	5.9	5.7	8.0	84.6	84.9	84.1	0.87	0.83	0.73	9.9	2.4	2.4	0.0040	64	37
LEX-LEN 112M1-2	4	2900	2.3	8.0	7.6	7.4	8.1	85.8	86.7	85.9	0.88	0.84	0.74	13.2	2.3	2.4	0.0057	72	47
LEX-LEN 132S1-2	5.5	2855	3.5	10.9	10.4	10.0	7.8	87.0	87.7	87.6	0.88	0.84	0.75	18.2	2.2	2.4	0.0112	75	65
LEX-LEN 132S2-2	7.5	2890	4.5	14.5	13.8	13.3	7.9	88.1	88.9	88.7	0.89	0.85	0.80	24.8	2.3	2.3	0.0134	62	73
LEX-LEN 160M1-2	11	2930	5.9	21.0	20.0	19.2	7.9	89.4	89.7	87.9	0.89	0.87	0.81	35.9	2.2	2.3	0.0391	76	122
LEX-LEN 160M2-2	15	2935	7.8	28.4	26.9	26.0	8.0	90.3	90.6	90.1	0.89	0.87	0.81	48.8	2.2	2.4	0.0464	69	133
LEX-LEN 160L-2	18.5	2930	7.7	34.7	33.0	31.8	8.0	90.9	91.2	91.0	0.89	0.87	0.81	60.2	2.3	2.3	0.0567	75	163
LEX-LEN 180M-2	22	2950	12.2	41.1	39.1	37.7	8.1	91.3	91.7	91.4	0.89	0.88	0.82	71.2	2.2	2.4	0.0783	74	190
LEX-LEN 200L1-2	30	2960	15.3	55.7	52.9	51.0	7.5	92.0	92.1	91.7	0.89	0.87	0.80	96.8	2.3	2.3	0.1277	83	252
LEX-LEN 200L2-2	37	2960	17.5	68.3	64.9	62.5	7.5	92.5	92.6	91.9	0.89	0.86	0.81	119.4	2.2	2.3	0.1432	84	275
LEX-LEN 225M-2	45	2965	21.4	82.7	78.6	75.7	7.6	92.9	92.8	91.6	0.89	0.87	0.80	144.8	2.2	2.3	0.2400	83	315
LEX-LEN 250M1-2	55	2965	31.3	100.7	95.7	92.2	7.6	93.2	93.8	93.3	0.89	0.86	0.82	177.0	2.2	2.3	0.3214	90	417
LEX-LEN 280S-2	75	2970	34.2	136.5	129.7	125.0	6.9	93.8	93.9	93.5	0.89	0.88	0.79	240.9	2.0	2.3	0.5964	89	572
LEX-LEN 280M1-2	90	2970	35.8	163.3	155.1	149.5	7.0	94.1	94.2	93.6	0.89	0.87	0.81	289.2	2.1	2.3	0.6953	87	605
LEX-LEN 315S-2	110	2980	45.5	196.9	187.1	180.3	7.1	94.3	94.5	93.9	0.90	0.89	0.81	352.7	2.0	2.2	1.2154	87	965
LEX-LEN 315M-2	132	2980	56.1	235.6	223.8	215.7	7.1	94.6	95.0	94.1	0.90	0.88	0.81	423.3	2.0	2.3	1.5965	86	1067
LEX-LEN 315L1-2	160	2975	60.6	281.8	267.7	258.0	7.1	94.8	94.9	94.2	0.91	0.88	0.82	513.8	2.1	2.3	1.8128	87	1151
LEX-LEN 315L2-2	200	2980	66.3	351.5	333.9	321.9	7.2	95.0	95.2	94.6	0.91	0.89	0.80	641.2	2.1	2.2	2.0806	88	1253
LEX-LEN 355M-2	250	2980	105.6	432.3	412.9	398.0	6.1	95.0	95.1	94.3	0.92	0.90	0.84	801.1	1.5	2.4	3.4977	103	1600
LEX-LEN 355L-2	315	2980	127.8	544.7	520.2	501.4	6.0	95.0	95.1	94.4	0.92	0.90	0.84	1009.6	1.5	2.3	4.4362	103	1850

DATI ELETTRICI - MOTORI TRIFASE - Serie LEX e LEN IE2
RATED DATA - THREE PHASE MOTORS - LEX and LEN Series IE2
POLI 4

4 Pole 1500 RPM Synchronous Speed 50Hz

TIPO TYPE	POTENZA OUTPUT KW	GIRI/min. r.p.m.	CORRENTE A VUOTO NO LOAD CURRENT V 400 A	CORRENTE FULL LOAD CURRENT			Ia/In Ia/In	RENDIMENTO EFFICIENCY			FATTORE DI POTENZA POWER FACTOR			RATED TORQUE Nm	Ca/Cn Ma/Mn	Cm/Cn Mk/Mn	Mom. In. Mom. of In. J (Kgm ²) dB (A)	RUMOR. NOISE LEVEL 1 m	MASSA MASS Kg.
				380V A	400V A	415V A		100%	75%	50% η	100%	75%	50%						
IE1 LEX-LEN 80M1-4	0.55	1405	1.0	1.5	1.5	1.4	4.6	72.7	72.2	70.2	0.75	0.67	0.55	3.7	2.5	2.8	0.002	54	15
LEX-LEN 80M2-4	0.75	1420	1.3	1.9	1.8	1.7	6.5	79.6	80.1	80.2	0.75	0.66	0.54	5.1	2.3	2.4	0.0026	50	20
LEX-LEN 90S-4	1.1	1420	1.7	2.7	2.6	2.5	6.6	81.4	81.8	80.4	0.75	0.67	0.60	7.4	2.3	2.4	0.0026	57	26
LEX-LEN 90L-4	1.5	1425	1.9	3.7	3.5	3.4	6.9	82.8	83.3	82.0	0.75	0.68	0.60	10.1	2.4	2.5	0.0031	59	29
LEX-LEN 100L1-4	2.2	1445	2.5	4.9	4.7	4.5	7.5	84.3	84.6	83.4	0.81	0.67	0.61	14.5	2.3	2.4	0.0073	58	37
LEX-LEN 100L2-4	3	1440	3.1	6.5	6.2	6.0	7.6	85.5	85.8	84.7	0.82	0.69	0.61	19.9	2.3	2.4	0.0073	58	40
LEX-LEN 112M-4	4	1440	4.1	8.6	8.1	7.8	7.7	86.6	87.3	86.9	0.82	0.71	0.63	26.5	2.3	2.5	0.0099	60	52
LEX-LEN 132S-4	5.5	1455	5.0	11.6	11.0	10.6	7.5	87.9	88.3	87.7	0.82	0.71	0.62	36.1	2.1	2.4	0.0223	72	70
LEX-LEN 132M1-4	7.5	1460	5.9	15.5	14.7	14.2	7.4	89.0	89.3	88.7	0.83	0.73	0.63	49.1	2.2	2.4	0.0308	62	84
LEX-LEN 160M-4	11	1465	7.9	21.9	20.8	20.0	7.5	89.8	90.0	89.4	0.85	0.72	0.62	71.6	2.3	2.4	0.0780	69	134
LEX-LEN 160L-4	15	1470	11.5	29.3	27.8	26.8	7.5	90.6	90.8	90.1	0.86	0.75	0.66	97.4	2.2	2.4	0.0957	71	169
LEX-LEN 180M-4	18.5	1470	12.2	35.8	34.0	32.8	7.7	91.2	91.8	91.0	0.86	0.76	0.71	120.0	2.3	2.5	0.1446	75	196
LEX-LEN 180L-4	22	1470	14.8	42.4	40.3	38.9	7.8	91.6	92.0	91.6	0.86	0.78	0.72	142.7	2.2	2.4	0.1643	70	242
LEX-LEN 200L-4	30	1470	17	57.4	54.6	52.6	7.2	92.3	92.4	91.8	0.86	0.79	0.73	194.5	2.2	2.4	0.2725	76	275
LEX-LEN 225S-4	37	1480	24	70.5	67.0	64.6	7.3	92.7	92.9	92.5	0.86	0.79	0.75	238.6	2.2	2.4	0.4222	77	328
LEX-LEN 225M-4	45	1480	24.5	85.4	81.1	78.2	7.4	93.1	93.4	93.0	0.86	0.81	0.73	290.1	2.2	2.3	0.4878	76	355
LEX-LEN 250M1-4	55	1480	31.7	103.9	98.7	95.2	7.4	93.5	93.7	93.6	0.86	0.81	0.74	354.5	2.2	2.3	0.6864	81	451
LEX-LEN 280S-4	75	1485	35.6	137.8	130.9	126.1	6.7	94.0	94.1	93.7	0.88	0.84	0.79	481.8	2.3	2.4	1.1648	81	591
LEX-LEN 280M1-4	90	1485	43.5	165.0	156.7	151.0	6.9	94.2	94.3	93.7	0.88	0.84	0.80	578.3	2.3	2.3	1.5184	77	692
LEX-LEN 315S-4	110	1485	49.9	201.0	190.9	184.0	6.9	94.5	94.7	94.2	0.88	0.85	0.83	706.3	2.2	2.3	3.2344	84	1012
LEX-LEN 315M-4	132	1485	64.5	240.7	228.6	220.4	6.9	94.7	94.6	94.3	0.88	0.86	0.82	848.0	2.2	2.3	3.4216	82	1147
LEX-LEN 315L1-4	160	1485	79.8	287.8	273.4	263.6	6.9	94.9	95.0	94.6	0.89	0.87	0.84	1027.5	2.2	2.3	3.9416	94	1224
LEX-LEN 315L2-4	200	1485	101	359.0	341.1	328.7	6.9	95.1	94.9	94.6	0.89	0.87	0.83	1285.1	2.2	2.3	4.6696	85	1331
LEX-LEN 355M-4	250	1490	102	443.8	421.6	406.4	6.7	95.1	95.1	94.6	0.90	0.88	0.84	1603.9	2.1	2.5	8.4044	101	1650
LEX-LEN 355L-4	315	1490	99.8	559.2	531.2	512.0	7.1	95.1	95.0	94.8	0.90	0.89	0.84	2020.3	2.1	2.5	9.9325	101	2040

DATI ELETTRICI - MOTORI TRIFASE - Serie LEX e LEN IE2
RATED DATA - THREE PHASE MOTORS - LEX and LEN Series IE2
POLI 6

6 Pole 1000 RPM Synchronous Speed 50Hz

TIPO TYPE	POTENZA OUTPUT KW	GIRI/min. r.p.m.	CORRENTE A VUOTO NO LOAD CURRENT V 400 A	CORRENTE FULL LOAD CURRENT			Ia/In Ia/In	RENDIMENTO EFFICIENCY			FATTORE DI POTENZA POWER FACTOR			RATED TORQUE Nm	Ca/Cn Ma/Mn	Cm/Cn Mk/Mn	Mom. In. Mom. of In. J (Kg ^{m2}) dB (A)	RUMOR. NOISE LEVEL 1 m	MASSA MASS Kg.
				380V A	400V A	415V A		100%	75%	50%	η	100%	cos γ 75%						
IE1 LEX-LEN 80M1-6	0.37	916	0.9	1.3	1.2	1.1	3.3	63.5	63.4	56.2	0.70	0.63	0.50	3.9	1.9	2	0.002	46	17
IE1 LEX-LEN 80M2-6	0.55	915	1.1	1.6	1.6	1.5	3.2	69.3	69.0	67.3	0.72	0.62	0.53	5.7	2.1	2.4	0.003	50	20
LEX-LEN 90S-6	0.75	945	1.5	2.1	2.0	1.9	5.8	75.9	75.0	71.1	0.72	0.64	0.52	7.6	2.1	2.3	0.0032	53	24
LEX-LEN 90L-6	1.1	945	1.9	2.9	2.8	2.7	5.9	78.1	78.3	76.2	0.73	0.65	0.54	11.1	2.1	2.3	0.0042	68	28
LEX-LEN 100L-6	1.5	955	2.4	3.9	3.7	3.5	6.0	79.8	80.0	78.3	0.74	0.64	0.54	15.0	2.1	2.3	0.0074	58	34
LEX-LEN 112M-6	2.2	955	2.8	5.5	5.2	5.1	6.0	81.8	82.2	80.8	0.74	0.67	0.55	22.0	2.2	2.3	0.0147	61	45
LEX-LEN 132S-6	3	965	4.2	7.4	7.0	6.8	6.2	83.3	83.9	82.8	0.74	0.67	0.55	29.7	2.1	2.3	0.0305	62	60
LEX-LEN 132M1-6	4	965	5.1	9.7	9.2	8.9	6.8	84.6	85.1	84.2	0.74	0.69	0.58	39.5	2.0	2.2	0.0378	64	69
LEX-LEN 132M2-6	5.5	965	7.2	13.0	12.3	11.9	7.1	86.0	86.5	85.7	0.75	0.70	0.57	54.3	2.0	2.3	0.0473	61	82
LEX-LEN 160M-6	7.5	970	7.0	16.8	15.9	15.3	6.7	87.2	87.8	87.1	0.78	0.69	0.56	73.9	2.2	2.4	0.0924	68	114
LEX-LEN 160L-6	11	970	9.8	23.9	22.7	21.8	6.9	88.7	89.2	88.5	0.79	0.71	0.57	108.1	2.1	2.3	0.1218	70	154
LEX-LEN 180L-6	15	980	13.4	31.4	29.8	28.7	7.2	89.7	90.2	90.1	0.81	0.72	0.57	146.3	2.0	2.2	0.2174	73	197
LEX-LEN 200L1-6	18.5	980	14.5	38.4	36.5	35.1	7.2	90.4	90.6	90.0	0.81	0.74	0.62	180.1	2.2	2.3	0.3308	73	231
LEX-LEN 200L2-6	22	980	15.2	44.8	42.6	41.1	7.3	90.9	91.2	90.7	0.82	0.73	0.63	214.1	2.2	2.4	0.3780	71	240
LEX-LEN 225M-6	30	985	20.2	61.4	58.3	56.2	7.1	91.7	92.2	91.9	0.81	0.74	0.65	291.4	2.1	2.3	0.5744	73	302
LEX-LEN 250M-6	37	985	22.3	72.6	69.0	66.5	7.1	92.2	92.6	98.4	0.84	0.75	0.67	358.6	2.2	2.2	0.8757	75	387
LEX-LEN 280S-6	45	990	25.3	85.8	81.5	78.5	7.2	92.7	92.9	92.5	0.86	0.76	0.69	434.6	2.1	2.2	1.4700	79	502
LEX-LEN 280M1-6	55	990	28.8	104.4	99.2	95.6	7.2	93.1	93.3	92.9	0.86	0.75	0.68	531.2	2.1	2.1	1.7325	76	548
LEX-LEN 315S-6	75	990	44.1	143.1	135.9	131.0	6.7	93.7	93.6	92.8	0.85	0.80	0.73	722.8	2.0	2.1	4.3155	76	976
LEX-LEN 315M-6	90	990	49.2	173.2	164.5	158.6	6.7	94.0	93.9	93.3	0.84	0.81	0.74	867.3	2.0	2.1	4.4940	76	1007
LEX-LEN 315L1-6	110	990	54.2	208.5	198.1	190.9	6.7	94.3	94.4	93.7	0.85	0.88	0.78	1061.2	2.0	2.1	5.7225	78	1097
LEX-LEN 315L2-6	132	990	68.8	246.5	234.2	285.7	6.7	94.6	94.6	94.1	0.86	0.84	0.79	1271.6	2.0	2.2	6.4260	78	1168
LEX-LEN 355M1-6	160	990	91.9	294.1	279.4	269.3	6.5	95.0	94.9	94.4	0.87	0.84	0.80	1543.5	2.0	2.6	9.2925	81	1554
LEX-LEN 355M2-6	200	990	90.8	367.7	349.3	336.7	6.3	95.0	95.1	94.7	0.87	0.84	0.80	1929.9	1.9	2.5	11.9439	92	1814
LEX-LEN 355L-6	250	990	101	459.6	436.6	420.8	6.3	95.0	95.2	95.0	0.87	0.85	0.80	2415.3	1.7	2.2	13.3771	92	1980

DATI ELETTRICI - MOTORI TRIFASE - Serie LEX e LEN
RATED DATA - THREE PHASE MOTORS - LEX and LEN Series
POLI 8

8 Pole 750 RPM Synchronous Speed 50Hz

TIPO TYPE	POTENZA OUTPUT KW	GIRI/min. r.p.m.	CORRENTE A VUOTO NO LOAD CURRENT V 400 A	CORRENTE FULL LOAD CURRENT			Ia/In Ia/In	RENDIMENTO EFFICIENCY			FATTORE DI POTENZA POWER FACTOR			Cn Nm	Ca/Cn Ma/Mn	Cm/Cn Mk/Mn	Mom. In. Mom. of In. J (Kg·m²) dB (A)	RUMOR NOISE LEVEL 1 m	MASSA MASS Kg.
				380V A	400V A	415V A		100%	75%	50%	100%	75%	50%						
LEX-LEN 80M1-8	0.18	689	0.6	0.8	0.7	0.7	2.9	58.8	54.1	46.5	0.62	0.57	0.48	2.5	2.0	2.2	0.002	50	17
LEX-LEN 80M2-8	0.25	699	0.9	1.0	1.0	0.9	3.0	60.8	55.8	45.9	0.61	0.55	0.47	3.4	2.1	2.4	0.003	50	19
LEX-LEN 90S-8	0.37	702	1.2	1.4	1.4	1.3	3.4	65.1	64.2	57.5	0.61	0.54	0.45	5.0	2.0	2.4	0.004	53	23
LEX-LEN 90L-8	0.55	703	1.5	2.0	1.9	1.9	3.5	68.1	67.3	60.6	0.61	0.53	0.43	7.4	2.1	2.6	0.004	53	25
LEX-LEN 100L1.8	0.75	704	1.8	2.3	2.2	2.1	3.5	70.5	70.0	63.6	0.69	0.55	0.46	10.2	2.0	2.2	0.008	56	33
LEX-LEN 100L2-8	1.1	705	2.4	3.2	3.2	3.1	3.6	73.0	72.5	70.1	0.68	0.58	0.45	15.1	2.2	2.6	0.01	58	38
LEX-LEN 112M1-8	1.5	700	2.8	4.3	4.1	3.8	3.9	77.1	76.6	74.6	0.69	0.61	0.48	20.5	2.4	2.7	0.017	60	50
LEX-LEN 132S-8	2.2	710	3.9	5.8	5.6	5.3	4.3	80.0	79.4	79.3	0.71	0.64	0.53	29.6	2.3	2.5	0.031	63	66
LEX-LEN 132M1-8	3	710	4.0	7.6	7.2	6.8	4.4	80.8	80.5	78.8	0.75	0.66	0.54	40.4	2.2	2.4	0.04	64	72
LEX-LEN 132M2-8	4	711	5.5	9.6	9.3	8.9	4.5	81.4	81.1	79.8	0.76	0.68	0.56	53.8	2.1	2.6	0.04	65	78
LEX-LEN 160M1-8	4	716	5.6	9.8	9.5	9.1	4.4	81.9	81.4	80.0	0.74	0.67	0.58	53.4	2.2	2.2	0.075	65	123
LEX-LEN 160M2-8	5.5	721	7.8	13.4	12.5	12.0	5.0	86.2	85.8	84.6	0.74	0.66	0.55	72.9	2.2	2.8	0.093	66	134
LEX-LEN 160L-8	7.5	721	9.6	17.2	16.6	15.7	5.7	87.0	86.7	84.8	0.75	0.68	0.55	99.4	2.1	2.9	0.126	67	157
LEX-LEN 180L-8	11	719	12.0	24.9	23.8	23.2	5.6	87.5	87.1	85.2	0.77	0.71	0.6	146.2	2.3	2.8	0.203	68	195
LEX-LEN 200L-8	15	731	15.9	33.1	31.3	30.3	5.5	89.5	89.2	87.5	0.77	0.73	0.63	196.1	2.1	2.7	0.339	70	276
LEX-LEN 225S-8	18.5	731	20.3	41.5	39.6	38.4	5.6	90.2	89.8	87.8	0.75	0.71	0.64	241.8	2.2	2.8	0.491	72	326
LEX-LEN 225M-8	22	732	20.5	46.9	44.9	43.2	5.4	90.7	90.3	88.2	0.78	0.75	0.66	287.2	2.1	2.9	0.547	72	364
LEX-LEN 250M-8	30	736	27.4	61.3	59.4	58.0	5.3	90.6	90.3	88.3	0.80	0.77	0.69	389.5	2.2	2.6	0.83	74	460
LEX-LEN 280S-8	37	738	29.6	74.9	71.2	68.5	5.6	91.7	91.2	88.7	0.82	0.78	0.69	479.0	2.3	2.9	1.39	75	549
LEX-LEN 280M1-8	45	739	36.2	90.8	87.3	84.4	5.2	91.8	91.3	89.2	0.81	0.76	0.67	581.8	2.1	3.1	1.65	76	597
LEX-LEN 315S-8	55	739	41.5	107.6	102.9	98.5	5.7	93.6	93.4	91.8	0.82	0.78	0.71	711.1	1.9	2.8	4.79	78	1054
LEX-LEN 315M-8	75	741	51.3	147.7	139.6	133.3	5.9	93.9	93.6	92.1	0.83	0.80	0.72	967.1	2.1	2.5	5.58	81	1216
LEX-LEN 315L1-8	90	740	65.8	176.1	166.6	160.1	6.2	94.1	93.7	92.2	0.83	0.77	0.71	1162.1	2.3	2.7	6.37	80	1274
LEX-LEN 315L2-8	110	741	73.8	214.9	204.8	195.3	6.0	94.2	93.8	92.4	0.82	0.80	0.71	1418.4	2.3	2.6	7.23	80	1363
LEX-LEN 355M1-8	132	741	85.8	250.4	237.7	230.2	5.9	95.3	95.2	92.6	0.84	0.81	0.73	1702.1	1.9	2.6	7.55	82	1598
LEX-LEN 355M2-8	160	744	104.3	307.8	291.2	279.3	5.8	95.3	95.1	92.8	0.83	0.80	0.74	2054.8	1.7	2.4	11.73	88	1698
LEX-LEN 355L-8	200	745	112.1	370.5	354.3	340.4	5.7	95.7	95.5	93.2	0.85	0.84	0.78	2565.1	1.8	2.9	12.86	87	1798

FORMA COSTRUTTIVA B3 DIMENSIONS FOOTMOUNT B3

LEX-LEN 80 ÷ 132

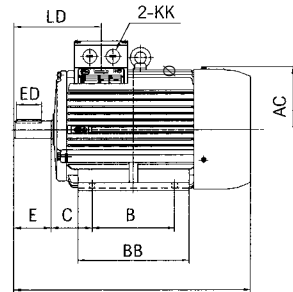
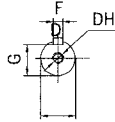
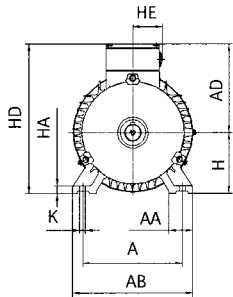

LEX-LEN 160 ÷ 280

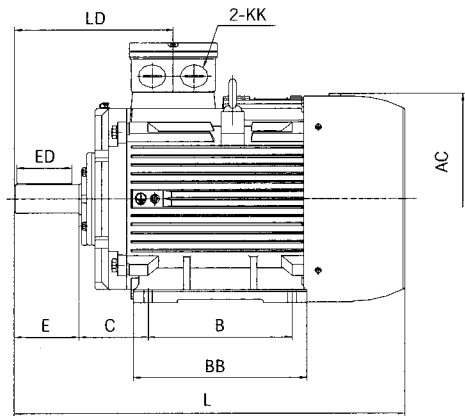
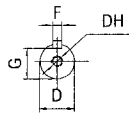
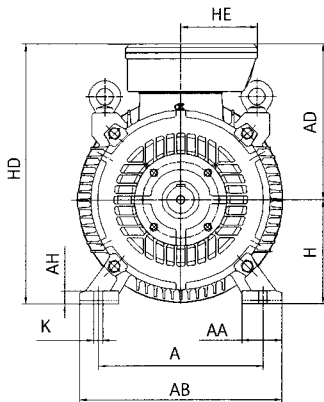

LEX-LEN 315 ÷ 355

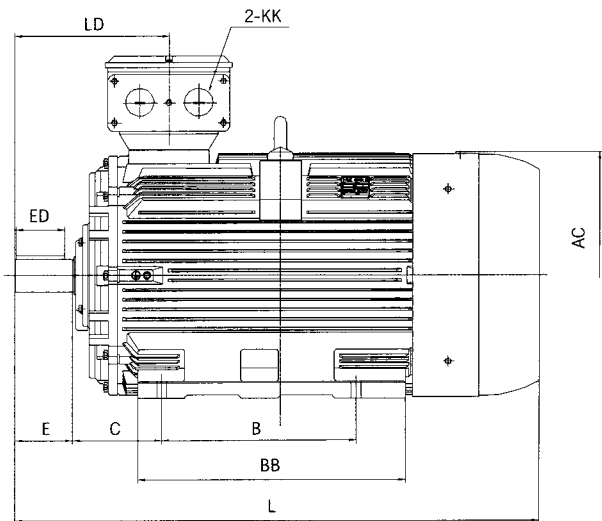
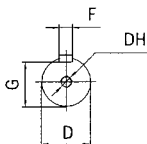
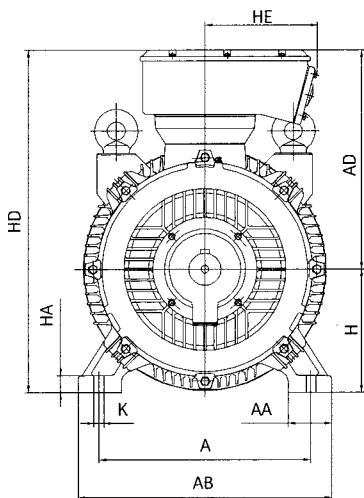

FORMA COSTRUTTIVA B3 DIMENSIONS FOOTMOUNT B3

Tipo/Frame	A	AA	AB	AC	AD	B	BB	C	D	DH	E	ED	F	G	H	HA	HD	HE	K	KK	L	LD
LEX-LEN 80	125	34	160	175	145	100	130	50	19	M6x16	40	25	6	15.5	80	10	225	50	10	M25x1.5	305	116
LEX-LEN 90S	140	36	180	190	170	100	160	56	24	M8x19	50	40	8	20	90	12.5	260	50	10	M25x1.5	360	131
LEX-LEN 90L	140	36	180	190	170	125	160	56	24	M8x19	50	40	8	20	90	12.5	260	50	10	M25x1.5	390	131
LEX-LEN 100	160	40	200	215	180	140	182	63	28	M10x22	60	45	8	24	100	14	280	70	12	M32x1.5	435	157
LEX-LEN 112	190	45	230	236	188	140	195	70	28	M10x22	60	45	8	24	112	14	300	70	12	M32x1.5	480	163
LEX-LEN 132S	216	52	265	275	213	140	245	89	38	M12x28	80	63	10	33	132	16	345	70	12	M32x1.5	515	188
LEX-LEN 132M	216	52	265	275	213	178	245	89	38	M12x28	80	63	10	33	132	16	345	70	12	M32x1.5	550	188
LEX-LEN 160M	254	67	320	330	250	210	260	108	42	M16x36	110	90	12	37	160	19	410	105	14.5	M40x1.5	622	268
LEX-LEN 160L	254	67	320	330	250	254	305	108	42	M16x36	110	90	12	37	160	19	410	105	14.5	M40x1.5	667	268
LEX-LEN 180M	279	74	350	380	275	241	297	121	48	M16x36	110	90	14	42.5	180	22	455	105	14.5	M40x1.5	685	273
LEX-LEN 180L	279	74	350	380	275	279	335	121	48	M16x36	110	90	14	42.5	180	22	455	105	14.5	M40x1.5	732	273
LEX-LEN 200	318	85	395	420	324	305	370	133	55	M20x42	110	90	16	49	200	25	524	166	18.5	M50x1.5	790	291
LEX-LEN 225S (4-8P)	356	80	436	465	335	286	355	149	60	M20x42	140	110	18	53	225	28	560	166	18.5	M50x1.5	841	340
LEX-LEN 225M (2P)	356	80	436	465	335	311	380	149	55	M20x42	110	90	16	49	225	28	560	166	18.5	M50x1.5	865	310
LEX-LEN 225M (4-8P)	356	80	436	465	335	311	380	149	60	M20x42	140	110	18	53	225	28	560	166	18.5	M50x1.5	870	340
LEX-LEN 250M (2P)	406	88	495	520	375	349	440	168	60	M20x42	140	110	18	53	250	33	625	161	24	M63x1.5	950	353
LEX-LEN 250M (4-8P)	406	88	495	520	375	349	440	168	65	M20x42	140	110	18	58	250	33	625	161	24	M63x1.5	955	353
LEX-LEN 280S (2P)	457	109	550	570	405	368	485	190	65	M20x42	140	110	18	58	280	35	685	161	24	M63x1.5	1020	365
LEX-LEN 280S (4-8P)	457	109	550	570	405	368	485	190	75	M20x42	140	110	20	67.5	280	35	685	161	24	M63x1.5	1020	365
LEX-LEN 280M (2P)	457	109	550	570	405	419	535	190	65	M20x42	140	110	18	58	280	35	685	161	24	M63x1.5	1020	365
LEX-LEN 280M (4-8P)	457	109	550	570	405	419	535	190	75	M20x42	140	110	20	67.5	280	35	685	161	24	M63x1.5	1020	365
LEX-LEN 315S (2P)	508	120	635	650	555	406	565	216	65	M20x42	140	110	18	58	315	45	870	308	28	M63x1.5	1180	376
LEX-LEN 315M (2P)	508	120	635	650	555	457	675	216	65	M20x42	140	110	18	58	315	45	870	308	28	M63x1.5	1290	376
LEX-LEN 315L (2P)	508	120	635	650	555	508	675	216	65	M20x42	140	110	18	58	315	45	870	308	28	M63x1.5	1290	376
LEX-LEN 315S (4-8P)	508	120	635	650	555	406	565	216	80	M20x42	170	140	22	71	315	45	870	308	28	M63x1.5	1210	406
LEX-LEN 315M (4-8P)	508	120	635	650	555	457	675	216	80	M20x42	170	140	22	71	315	45	870	308	28	M63x1.5	1320	406
LEX-LEN 315L (4-8)	508	120	635	650	555	508	675	216	80	M20x42	170	140	22	71	315	45	870	308	28	M63x1.5	1320	406
LEX-LEN 315L (4-8)	508	120	635	650	555	508	675	216	80	M20x42	170	140	22	71	315	45	870	308	28	M63x1.5	1320	406
LEX-LEN 355M (2P)	610	125	735	735	640	560	775	254	75	M24x50	140	110	20	67.5	355	49	995	310	28	M63x1.5	1490	415
LEX-LEN 355L (2P)	610	125	735	735	640	630	775	254	75	M24x50	140	110	20	67.5	355	49	995	321	28	M63x1.5	1490	415
LEX-LEN 355M (4-8P)	610	125	735	735	640	560	775	254	100	M24x50	210	140	28	86	355	49	995	321	28	M63x1.5	1560	445
LEX-LEN 355L (4-8P)	610	125	735	735	640	630	775	254	100	M24x50	210	140	28	86	355	49	995	321	28	M63x1.5	1560	445

FORMA COSTRUTTIVA B5 e V1
DIMENSIONS FOOTMOUNT B5 and V1

LEX-LEN 80 ÷ 132

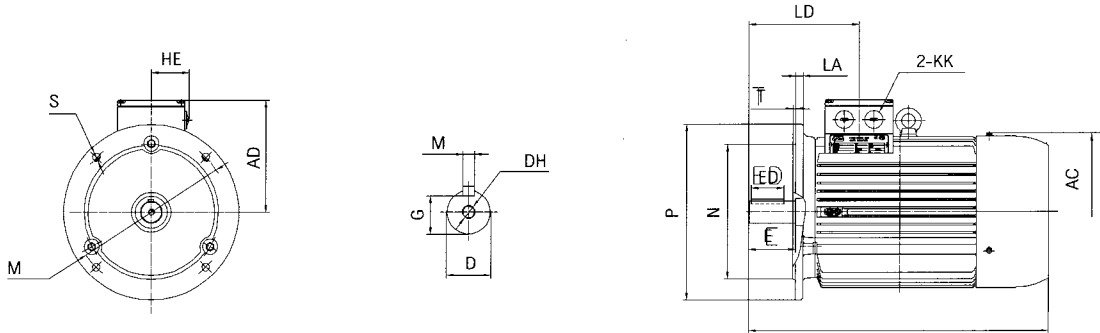

LEX-LEN 160 ÷ 280

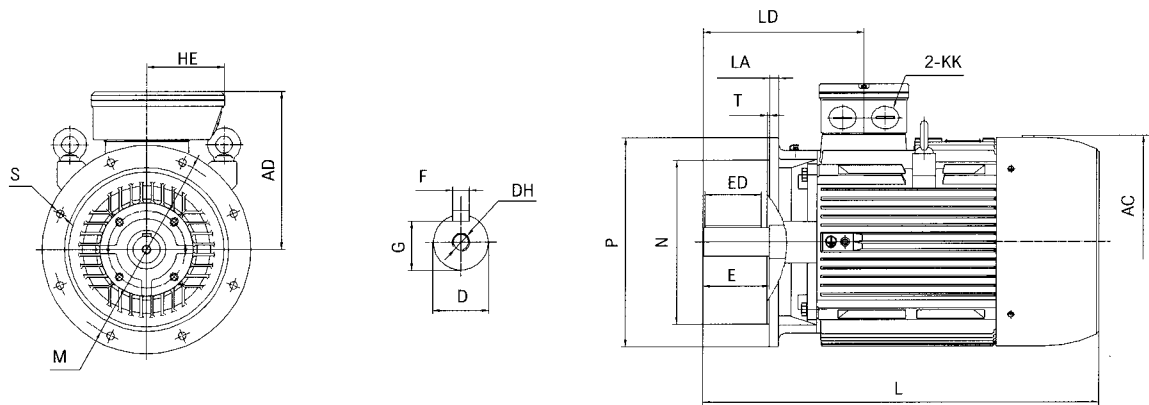

LEX-LEN 315 ÷ 355

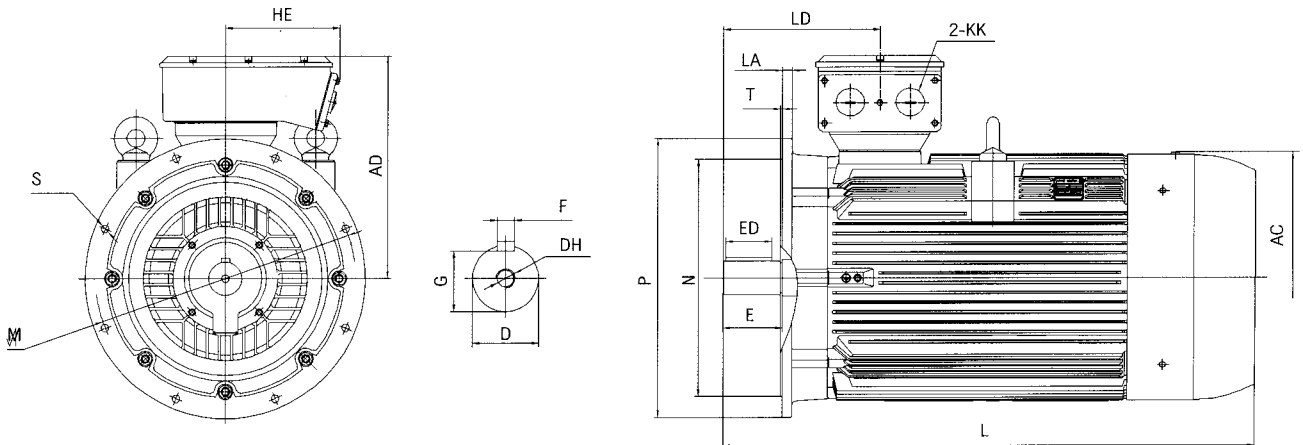

FORMA COSTRUTTIVA B5 e V1 DIMENSIONS FOOTMOUNT B5 and V1

Tipo/Frame	AC	AD	D	DH	E	ED	F	G	HE	KK	L	LA	LD	M	N	P	S	T
LEX-LEN 80	175	145	19	M6x16	40	25	6	15.5	50	M25x1.5	305	10	116	165	130	200	12	3.5
LEX-LEN 90S	190	165	24	M8x19	50	40	8	20	50	M25x1.5	360	12	131	165	130	200	12	3.5
LEX-LEN 90L	190	165	24	M8x19	50	40	8	20	50	M25x1.5	390	12	131	165	130	200	12	3.5
LEX-LEN 100	215	180	28	M10x22	60	45	8	24	70	M32x1.5	435	12	157	215	180	250	15	4
LEX-LEN 112	236	188	28	M10x22	60	45	8	24	70	M32x1.5	480	12	163	215	180	250	15	4
LEX-LEN 132S	275	213	38	M12x28	80	63	10	33	70	M32x1.5	515	13	188	265	230	300	15	4
LEX-LEN 132M	275	213	38	M12x28	80	63	10	33	70	M32x1.5	550	13	188	265	230	300	15	4
LEX-LEN 160M	330	250	42	M16x36	110	90	12	37	105	M40x1.5	622	15	268	300	250	350	18.5	5
LEX-LEN 160L	330	250	42	M16x36	110	90	12	37	105	M40x1.5	667	15	268	300	250	350	18.5	5
LEX-LEN 180M	380	275	48	M16x36	110	90	14	42.5	105	M40x1.5	685	15	273	300	250	350	18.5	5
LEX-LEN 180L	380	275	48	M16x36	110	90	14	42.5	105	M40x1.5	732	15	273	300	250	350	18.5	5
LEX-LEN 200	420	324	55	M20x42	110	90	16	49	166	M50x1.5	790	17	291	350	300	400	18.5	5
LEX-LEN 225S (4-8P)	465	335	60	M20x42	140	110	18	53	166	M50x1.5	841	20	340	400	350	450	18.5	5
LEX-LEN 225M (2P)	465	335	55	M20x42	110	90	16	49	166	M50x1.5	865	20	310	400	350	450	18.5	5
LEX-LEN 225M (4-8P)	465	335	60	M20x42	140	110	18	53	166	M50x1.5	870	20	340	400	350	450	18.5	5
LEX-LEN 250M (2P)	520	375	60	M20x42	140	110	18	53	161	M63x1.5	950	21	353	500	450	550	18.5	5
LEX-LEN 250M (4-8P)	520	375	65	M20x42	140	110	18	58	161	M63x1.5	955	21	353	500	450	550	18.5	5
LEX-LEN 280S (2P)	570	405	65	M20x42	140	110	18	58	161	M36x1.5	1020	22	365	500	450	550	18.5	5
LEX-LEN 280S (4-8P)	570	405	75	M20x42	140	110	20	67.5	161	M63x1.5	1020	22	365	500	450	550	18.5	5
LEX-LEN 280M (2P)	570	405	65	M20x42	140	110	18	58	161	M63x1.5	1020	22	365	500	450	550	18.5	5
LEX-LEN 280M (4-8P)	570	405	75	M20x42	140	110	20	67.5	161	M63x1.5	1020	22	365	500	450	550	18.5	5
LEX-LEN 315S (2P)	650	555	65	M20x42	140	110	18	58	308	M63x1.5	1180	24	376	600	550	660	24	6
LEX-LEN 315M (2P)	650	555	65	M20x42	140	110	18	58	308	M63x1.5	1290	24	376	600	550	660	24	6
LEX-LEN 315L (2P)	650	555	65	M20x42	140	110	18	58	308	M63x1.5	1290	24	376	600	550	660	24	6
LEX-LEN 315L (2P)	650	555	65	M20x42	140	110	18	58	308	M63x1.5	1290	24	376	600	550	660	24	6
LEX-LEN 315S (4-8P)	650	555	80	M20x42	170	140	22	71	308	M63x1.5	1210	24	406	600	550	660	24	6
LEX-LEN 315M (4-8P)	650	555	80	M20x42	170	140	22	71	308	M63x1.5	1320	24	406	600	550	660	24	6
LEX-LEN 315L (4-8P)	650	555	80	M20x42	170	140	22	71	308	M63x1.5	1320	24	406	600	550	660	24	6
LEX-LEN 355M (2P)	735	640	75	M24x50	140	110	20	67.5	321	M63x1.5	1490	25	415	740	680	800	24	6
LEX-LEN 355L (2P)	735	640	75	M24x50	140	110	20	67.5	321	M63x1.5	1490	25	415	740	680	800	24	6
LEX-LEN 355M (4-8P)	735	640	100	M24x50	210	140	25	86	321	M63x1.5	1560	25	445	740	680	800	24	6
LEX-LEN 355L (4-8P)	735	640	100	M24x50	210	140	25	86	321	M63x1.5	1560	25	445	740	680	800	24	6

MORSETTIERA TERMINAL BOX

LEX-LEN 80-132

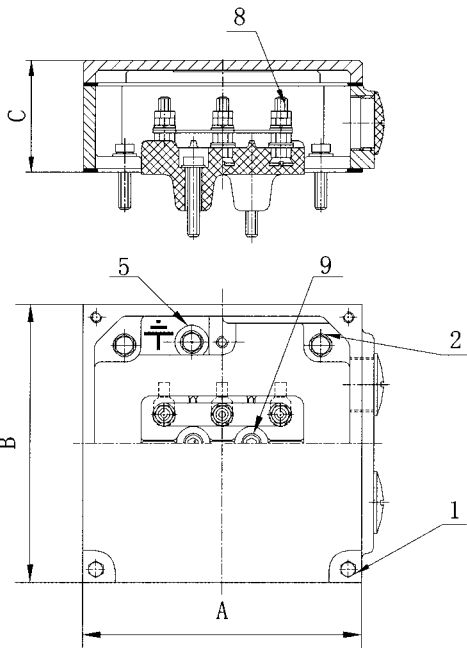

LEX-LEN 160-315

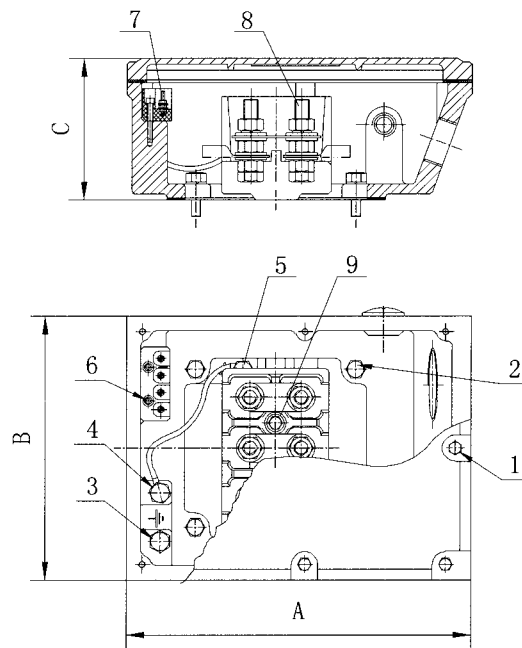

LEX-LEN 355

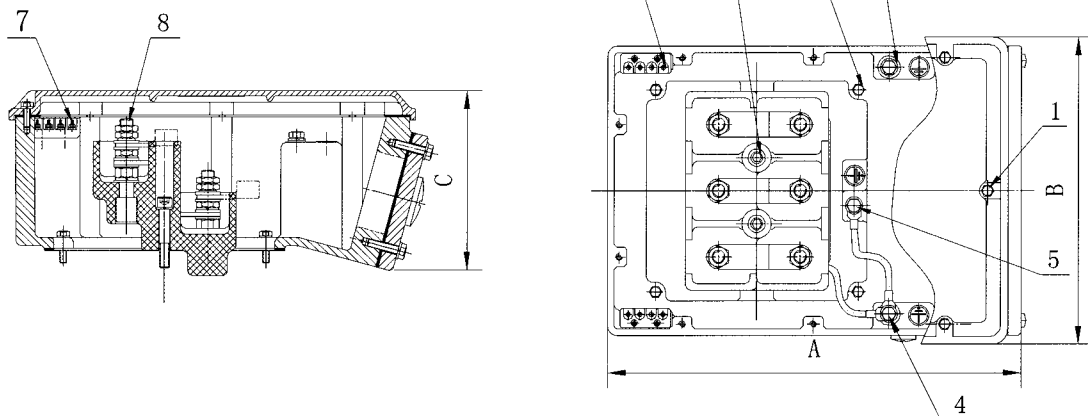

Tipo	A	B	C	1	2	3**	4**	5**	6	7	8	9	Pressacavi metrici
Frame													Metric Gland Sizes
LEX-LEN 80-90	100	100	46	M5x16	M6x16	N/A	N/A	M6x10	N/A	N/A	M4	M6x25	2xM25
LEX-LEN 100-132	118	118	59	M5x16	M6x16	N/A	N/A	M6x10	N/A	N/A	M5	M6x25	2xM32
LEX-LEN 160-180	200	164	83	M6x16	M6x20	M8x16	M8x16	M8x16	M4x25	M3	M8	M8x30	2xM40
LEX-LEN 200-225	285	190	109	M6x25	M8x30	M8x16	M8x16	M8x16	M4x25	M3	M10	M8x30	2xM50
LEX-LEN 250-280	284	218	119	M6x25	M8x30	M10x20	M10x20	M10x20	M4x25	M3	M10	M10x30	2xM63
LEX-LEN 315	441	326	195	M8x30	M8x30	M10x16	M10x16	M10x16	M4x25	M3	M12	M10x50	2xM63
LEX-LEN 355	490	365	220	M8x30	M8x30	M10x25	M10x25	M10x25	M4x25	M3	M16	M12x80	2xM63

** Morsetto di messa a terra

** Earth stud on the T/Box

CUSCINETTI E ANELLI DI TENUTA BEARING & OIL SEAL INFORMATION

CUSCINETTI BEARING DATA

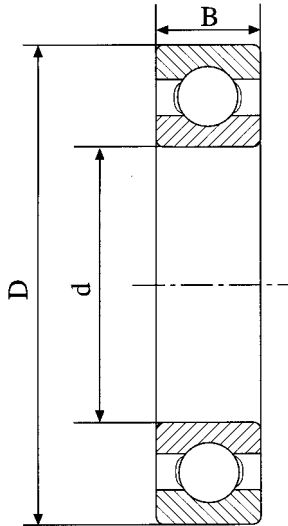

Tipo/Frame	DE	NDE	d	D	B
LEX-LEN 80	6204 ZZ C3	6204 ZZ C3	20	47	14
LEX-LEN 90	6205 ZZ C3	6205 ZZ C3	25	52	15
LEX-LEN 100	6206 ZZ C3	6206 ZZ C3	30	62	16
LEX-LEN 112	6306 ZZ C3	6306 ZZ C3	30	72	19
LEX-LEN 132	6308 ZZ C3	6308 ZZ C3	40	90	23
LEX-LEN 160	6309 C3	6309 C3	45	100	25
LEX-LEN 180	6311 C3	6311 C3	55	120	29
LEX-LEN 200	6312 C3	6312 C3	60	130	31
LEX-LEN 225	6313 C3	6313 C3	65	140	33
LEX-LEN 250	6314 C3	6314 C3	70	150	35
LEX-LEN 280 2P	6314 C3	6314 C3	70	150	35
LEX-LEN 280 4-8P	6316 C3	6316 C3	80	170	39
LEX-LEN 315 2P (Orizzontale/Horizontal)	6316 C3	6316 C3	80	170	39
LEX-LEN 315 2P (Verticale/Vertical)	6316 C3	7316	80	170	39
LEX-LEN 315 4-8P (Orizzontale/Horizontal)	NU319 C3	6319 C3	95	200	45
LEX-LEN 315 4-8P (Verticale/Vertical)	NU319 C3	7319	95	200	45
LEX-LEN 355 2P (Orizzontale/Horizontal)	6319 C3	6319 C3	95	200	45
LEX-LEN 355 2P (Verticale/Vertical)	6319 C3	7319	95	200	45
LEX-LEN 355 4-8P (Orizzontale/Horizontal)	NU322	6322 C3	110	240	50
LEX-LEN 355 4-8P (Verticale/Vertical)	NU322 C3	7322	110	240	50

ANELLI DI TENUTA OIL SEAL DATA

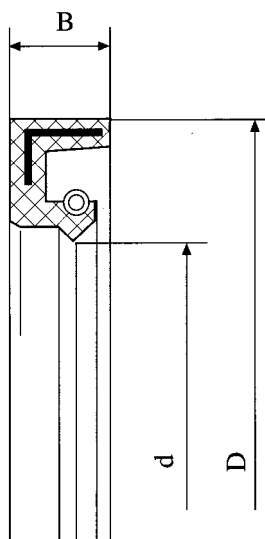

Tipo/Frame	DE			NDE		
	d	D	B	d	D	B
LEX-LEN 80	20	35	5	20	35	5
LEX-LEN 90	25	40	5	25	40	5
LEX-LEN 100	30	52	7	30	52	7
LEX-LEN 112	30	52	7	30	52	7
LEX-LEN 132	40	62	5	40	62	5
LEX-LEN 160	45	65	8	45	65	8
LEX-LEN 180	55	75	8	55	75	8
LEX-LEN 200	60	80	8	60	80	8
LEX-LEN 225	65	90	10	65	90	10
LEX-LEN 250	70	95	10	70	95	10
LEX-LEN 280 2P	70	95	10	70	95	10
LEX-LEN 280 4-8P	80	100	10	80	100	10
LEX-LEN 315 2P	80	100	10	80	100	10
LEX-LEN 315 4-8P	95	120	12	95	120	12
LEX-LEN 355 2P	95	120	12	95	120	12
LEX-LEN 355 4-8P	110	140	12	110	140	12

CUSCINETTI E INTERCUSCINETTI E INTERVALLI DI LUBRIFICAZIONE BEARING SIZES & REGREASING INFORMATION

Standard: I cuscinetti schermati ZZ non richiedono ingrassaggio.

Standard: "Sealed for life" double shielded ZZ bearings
motor clearance or C3 not regreasable.

Tipo <i>IEC frame size</i>	Cuscinetto lato comando <i>Bearing drive end (D.E.)</i>	Cuscinetto lato ventola <i>Bearing non drive end (N.D.E.)</i>	Intervallo di lubrificazione con temperatura di utilizzo del cuscinetto fino a 70°C un condizioni normali <i>Regreasing period hours for operating temperatures up to 70° C</i>			Quantità di grasso in grammi
			RPM<3600	RPM<1800	RPM<1200	<i>Quantity of grease in bearing chamber if open bearings are fitted</i> GRAMS
LEX-LEN 80	6204ZZC3	6204ZZC3	30000	30000	30000	3.5
LEX-LEN 90	6205ZZC3	6205ZZC3	28000	30000	30000	4
LEX-LEN 100	6206ZZC3	6206ZZC3	25000	30000	30000	6
LEX-LEN 112	6306ZZC3	6306ZZC3	20000	20000	30000	7
LEX-LEN 132	6308ZZC3	6308ZZC3	15000	20000	30000	10.5

CUSCINETTI E INTERVALLI DI LUBRIFICAZIONE BEARING SIZES & REGREASING INFORMATION

Standard: Cuscinetti aperti senza sistema di lubrificazione automatica.

Standard: *Regreasable open bearing
C3 clearance without automatic grease relief.*

Tipo <i>IEC frame size</i>	Cuscinetto lato comando <i>Bearing drive end (D.E.)</i>	Cuscinetto lato ventola <i>Bearing non drive end (N.D.E.)</i>	Intervallo di lubrificazione con temperatura di utilizzo del cuscinetto fino a 70°C un condizioni normali <i>Regreasing period hours for operating temperatures up to 70° C</i>			Quantità di grasso in grammi <i>Quantity of grease in bearing chamber if open bearings are fitted</i>
			RPM<3600	RPM<1800	RPM<1200	
LEX-LEN 160	6309 C3	6309 C3	6000	12000	18000	13
LEX-LEN 180	6311 C3	6311 C3	4000	11000	16000	15
LEX-LEN 200	6312 C3	6312 C3	3500	8500	13000	20
LEX-LEN 200*	NU312	6312 C3	1800	4250	6500	20
LEX-LEN 225	6313 C3	6313 C3	3000	6000	9000	22
LEX-LEN 225*	NU313	6313 C3	1500	3000	4500	22
LEX-LEN 250	6314 C3	6314 C3	2000	5000	8000	23
LEX-LEN 250*	NU314	6314 C3	1000	2500	4000	23
LEX-LEN 280 2P	6314 C3	6314 C3	1200	-	-	30
LEX-LEN 280 4-8P	6316 C3	6316 C3	-	4000	6000	30
LEX-LEN 280 4-8P*	NU316	6316 C3	600	2000	3500	30
LEX-LEN 315 2P	6316 C3	6316 C3	1200	-	-	30
LEX-LEN 315 4-8P	NU319 C3	6319 C3	-	2000	3000	45
LEX-LEN 355 2P	6319 C3	6319 C3	1200	-	-	30
LEX-LEN 355 4-8P	NU322 C3	6322 C3	-	1400	2200	60

Note:

1. I motori in verticale devono essere ingrassati il doppio dei motori in orizzontale.
2. È raccomandato sostituire i cuscinetti schermati (ZZ) con nuovi cuscinetti schermati (ZZ) al termine dell'intervallo di lubrificazione.
3. L'intervallo di lubrificazione viene ridotto se la temperatura di esercizio del cuscinetto supera i 70°C.

Notes:

1. Vertical motors should be greased twice as often as horizontal motors.
2. It is recommended that "Cealed for life" bearings are replaced with new bearings when they are due for regreasing. It is possible to remove the shield from the out board side of these bearings, clean them out, and repack them with fresh grease, but it is non recommended. (The grease is retained between the inboard bearing shield and the oilseal in the endshield, as all motors are IP55 and fitted with an oilseal at both ends).
3. Regreasing time should be reduced if bearing operating temperature is in excess of 70° C.

SPECIFICHE, DISPOSIZIONE E DESCRIZIONE MOTORE TIPO LEX-LEN80-132 SPECIFICATION, ARRANGEMENT AND PARTS LIST LEX-LEN80-132 FRAME

- 1 Scudo anteriore con anello di tenuta.
- 2 Molla di precarico.
- 3 Cuscinetto anteriore.
- 4 Morsetto di messa a terra esterno.
- 5 Scatola morsetti.
- 6 Coperchio scatola morsetti.
- 7 Statore.
- 8 Rotore.
- 9 Carcassa.
- 10 Scudo posteriore con anello di tenuta.
- 11 Cuscinetto posteriore.
- 12 Ventola.
- 13 Copriventola.

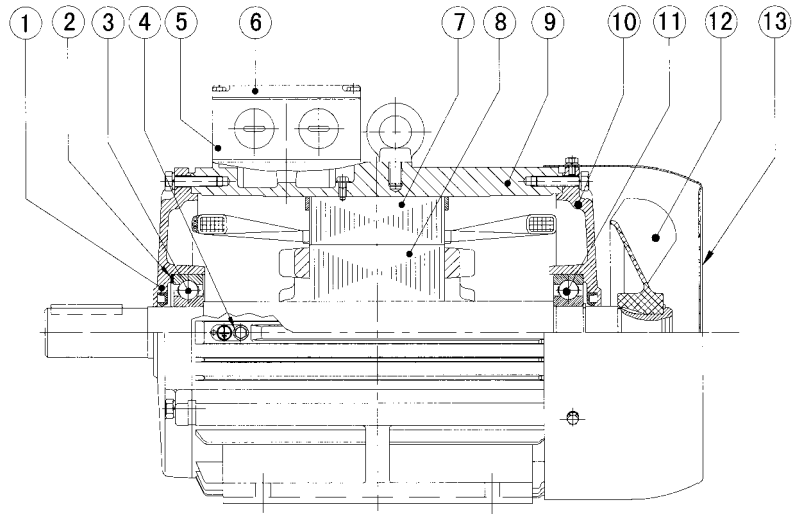

- 1 *Endshield D. E. with oil seal.*
- 2 *Wave Washer*
- 3 *Bearing D. E.*
- 4 *External Earth Stud.*
- 5 *Terminal Box.*
- 6 *Terminal Box Lid.*
- 7 *Stator lamination pack.*
- 8 *Rotor lamination pack.*
- 9 *Stator Frame.*
- 10 *Endshield N. D. E. with oil seal.*
- 11 *Bearing N. D. E.*
- 12 *Fan.*
- 13 *Fan cowl.*

SPECIFICHE, DISPOSIZIONE E DESCRIZIONE MOTORE TIPO LEX-LEN160-280 SPECIFICATION, ARRANGEMENT AND PARTS LIST LEX-LEN160-280 FRAME

- 1 Coperchio esterno del cuscinetto anteriore con anello di tenuta.
- 2 Molla di precarico.
- 3 Cuscinetto anteriore.
- 4 Coperchio interno del cuscinetto anteriore.
- 5 Scudo anteriore.
- 6 Coperchio scatola morsetti.
- 7 Scatola morsetti.
- 8 Morsetto di messa a terra esterno.
- 9 Rotore.
- 10 Statore.
- 11 Targa motore.
- 12 Carcassa.
- 13 Coperchio interno del cuscinetto posteriore.
- 14 Scudo posteriore.
- 15 Ventola.
- 16 Copriventola.
- 17 Cuscinetto posteriore.
- 18 Coperchio esterno del cuscinetto posteriore con anello di tenuta.

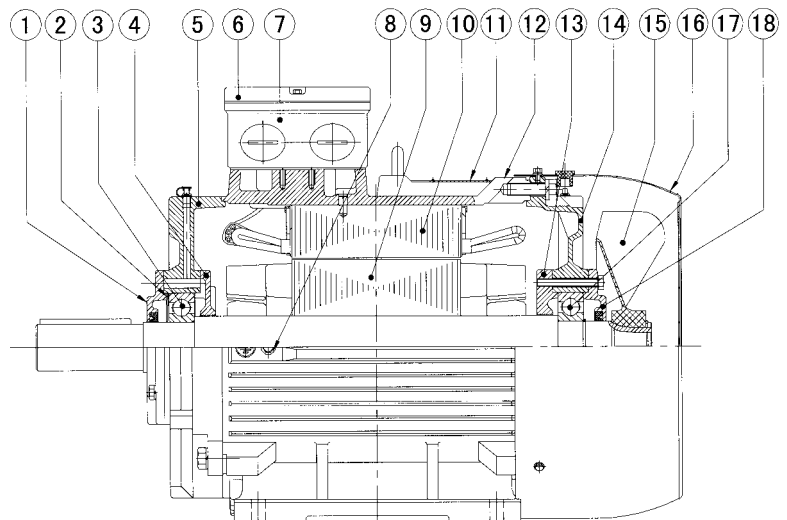

- 1 *Outer Bearing Cap D. E. with oil seal.*
- 2 *Wave Washer.*
- 3 *Bearing D. E.*
- 4 *Inner Bearing Cap D. E.*
- 5 *Endshield D. E.*
- 6 *Terminal Box Lid.*
- 7 *Terminal Box.*
- 8 *External Earth Stud.*
- 9 *Rotor lamination pack.*
- 10 *Stator lamination pack.*
- 11 *Nameplate.*
- 12 *Stator Frame.*
- 13 *Inner Bearing Cap N. D. E.*
- 14 *Endshield N. D. E.*
- 15 *Fan.*
- 16 *Fan cowl.*
- 17 *Bearing N. D. E.*
- 18 *Outer Bearing Cap N. D. E. with oil seal.*

SPECIFICHE, DISPOSIZIONE E DESCRIZIONE MOTORE TIPO LEX-LEN315-355 SPECIFICATION, ARRANGEMENT AND PARTS LIST LEX-LEN315-355 FRAME

- 1 Labirinto anteriore.
- 2 Coperchio esterno del cuscinetto anteriore con anello di tenuta.
- 3 Cuscinetto anteriore.
- 4 Coperchio interno del cuscinetto anteriore.
- 5 Scudo anteriore.
- 6 Scatola morsettiera.
- 7 Coperchio scatola morsettiera.
- 8 Adattatore scatola morsettiera.
- 9 Piastra pressocavi removibile.
- 10 Morsetto di messa a terra esterno.
- 11 Lamierino statore.
- 12 Lamierino rotore.
- 13 Carcassa.
- 14 Coperchio interno del cuscinetto posteriore.
- 15 Scudo posteriore.
- 16 Ventola.
- 17 Copriventola.
- 18 Cuscinetto posteriore.
- 19 Coperchio esterno del cuscinetto posteriore con anello di tenuta.
- 20 Labirinto posteriore.

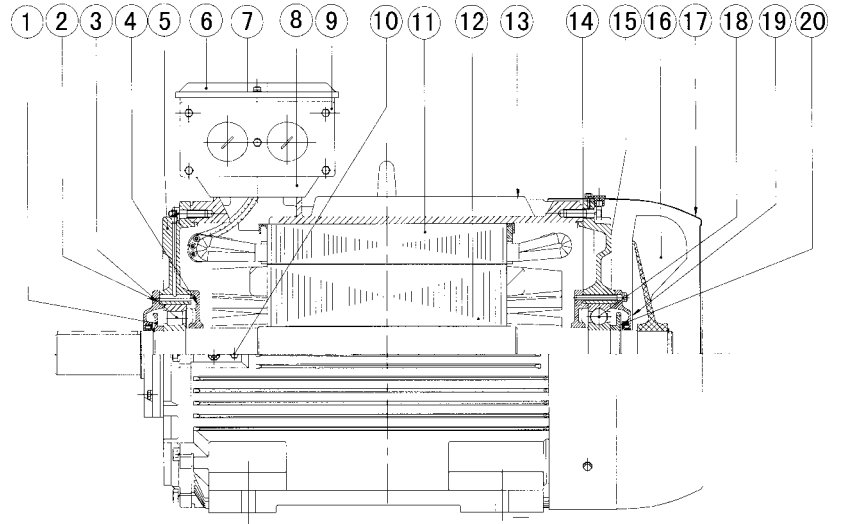

- 1 *Flinger D. E.*
- 2 *Outer Bearing Cap D. E. with oil seal.*
- 3 *Bearing D. E.*
- 4 *Inner Bearing Cap D. E.*
- 5 *Endshield D. E.*
- 6 *Terminal Box.*
- 7 *Terminal Box Lid.*
- 8 *Terminal Box Adapter*
- 9 *Removable Gland Plate.*
- 10 *External Earth Stud.*
- 11 *Stator lamination pack.*
- 12 *Rotor lamination pack.*
- 13 *Stator Frame.*
- 14 *Inner Bearing Cap N. D. E.*
- 15 *Endshield N. D. E.*
- 16 *Fan.*
- 17 *Fan cowl.*
- 18 *Bearing N. D. E.*
- 19 *Outer Bearing Cap N. D. E. with oil seal.*
- 20 *Flinger N. D. E.*