

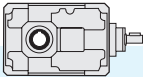

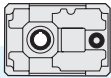

INDICE		INDEX	INHALTSVERZEICHNIS	
<b>1.0</b>	<b>GENERALITA'</b>	<b>GENERAL INFORMATION</b>	<b>ALLGEMEINES</b>	<b>2</b>
1.1	Unità di misura	<i>Measurement units</i>	Maßeinheiten	2
1.2	Fattore di servizio	<i>Service factor</i>	Betriebsfaktor	2
1.3	Selezione	<i>Selection</i>	Wahl	4
1.4	Potenza termica	<i>Thermal power</i>	Thermische Leistung	5
1.5	Verifica del dispositivo antiritorno	<i>Check out of the backstop device</i>	Prüfung der Rücklaufsperr	6
1.6	Lubrificazione	<i>Lubrication</i>	Ölschmierung	8
1.7	Installazione	<i>Installation</i>	Einbau	9
1.8	Rodaggio	<i>Running-in</i>	Einfahren	10
1.9	Manutenzione	<i>Maintenance</i>	Wartung	10
				
<b>2.0</b>	<b>RIDUTTORI AD ASSI ORTOGONALI T</b>	<b>BEVEL HELICAL GEARBOX T</b>	<b>KEGELSTIRNRADGETRIEBE T</b>	<b>11</b>
				
<b>3.0</b>	<b>RIDUTTORI AD ASSI PARALLELI Z</b>	<b>PARALLEL SHAFT GEARBOX Z</b>	<b>PARALLELENGETRIEBE Z</b>	<b>45</b>
				
<b>4.0</b>	<b>RIDUTTORI PENDOLARI P</b>	<b>SHAFT-MOUNTED GEARBOX P</b>	<b>AUFSTECKGETRIEBE P</b>	<b>69</b>
				
<b>5.0</b>	<b>RIDUTTORI PENDOLARI M</b>	<b>SHAFT-MOUNTED GEARBOX M</b>	<b>AUFSTECKGETRIEBE M</b>	<b>85</b>
				
<b>6.0</b>	<b>RINVII ANGOLARI R</b>	<b>RIGHT ANGLE GEARBOX R</b>	<b>WINKELGETRIEBE R</b>	<b>95</b>
				
<b>7.0</b>	<b>RINVII ANGOLARI L</b>	<b>RIGHT ANGLE GEARBOX L</b>	<b>WINKELGETRIEBE L</b>	<b>111</b>
				
<b>8.0</b>	<b>RINVII ANGOLARI RL</b>	<b>RIGHT ANGLE GEARBOX RL</b>	<b>WINKELGETRIEBE RL</b>	<b>127</b>
				
<b>9.0</b>	<b>VARIATORI N</b>	<b>VARIATORS N</b>	<b>VERSTELLGETRIEBE N</b>	<b>135</b>
				
<b>10.0</b>	<b>VARIATORI UDL</b>	<b>VARIATORS UDL</b>	<b>VERSTELLGETRIEBE UDL</b>	<b>147</b>
<b>11.0</b>	<b>MOTORI ELETTRICI</b>	<b>ELECTRIC MOTORS</b>	<b>ELEKTROMOTOREN</b>	<b>153</b>

1.0 GENERALITA'

1.0 GENERAL INFORMATION

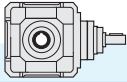
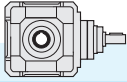
1.0 ALLGEMEINES

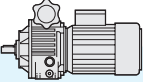
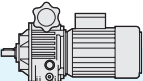
1.1 Unità di misura

1.1 Measurement units

1.1 Maßeinheiten

Tab. 1

SIMBOLO SYMBOL SYMBOL	DEFINIZIONE	DEFINITION	BEZEICHNUNG	UNITA' DI MISURA MEASUREMENT UNIT MAßEINHEIT
Fr <sub>1-2</sub>	Carico Radiale	Radial load	Radialbelastung	N
Fa <sub>1-2</sub>	Carico Assiale	Axial load	Axialbelastung	N
	Dimensioni	Dimensions	Abmessungen	mm
FS	Fattore di servizio	Service factor	Betriebsfaktor	
kg	Massa	Mass	Masse	kg
T <sub>2M</sub>	Momento torcente riduttore	Gearbox torque	Getriebe Drehmoment	Nm
T <sub>2</sub>	Momento torcente motorid.	Gearmotor torque	Getriebemotor Drehmoment	Nm
P	Potenza motore	Motor power	Motor Leistung	kW
Pc	Potenza corretta	Corrected power	Verbesserte Leistung	kW
P1	Potenza motoriduttore	Gearmotor power	Getriebemotor Leistung	kW
P <sub>10</sub>	Potenza termica	Thermal power	Thermische Leistung	kW
P'	Potenza richiesta in uscita	Output power	Erforderliche Abtriebsleistung	kW
RD	Rendimento dinamico	Dynamic efficiency	Dynamischer Wirkungsgrad	
in	Rapp. di trasm. nominale	Rated reduction ratio	Nennuntersetzung	
ir	Rapporto di trasmissione reale	Actual reduction ratio	Reelle Untersetzung	
n <sub>1</sub>	Velocità albero entrata	Input speed	Antriebsdrehzahl	min <sup>-1</sup>
n <sub>2</sub>	Velocità albero uscita	Output speed	Abtriebsdrehzahl	1 min <sup>-1</sup> = 6.283 rad.
Tc	Temperatura ambiente	Ambient temperature	Umgebungstemperatur	°C
η	Rendimento	Efficiency	Wirkungsgrad	
IEC	Motori accoppiabili	Motor options	Passende Motoren	

1.2 Fattore di servizio

1.2 Service factor

1.2 Betriebsfaktor

Il fattore di servizio **FS** permette di qualificare, in prima approssimazione, la tipologia dell'applicazione tenendo conto della natura del carico (A, B, C), della durata di funzionamento h/gg (ore giornaliere) e del numero di avviamenti/ora. Il coefficiente così trovato dovrà essere uguale o inferiore al fattore di servizio del riduttore **FS'** dato dal rapporto fra la coppia nominale del riduttore T<sub>2M</sub> indicata a catalogo e la coppia T<sub>2'</sub> richiesta dall'applicazione.

*Service factor **FS** enables approximate qualification of the type of application, taking into account type of load (A,B,C), length of operation h/d (hours/day) and the number of starts-up/hour. The coefficient thus calculated must be equal to or lower than the gear unit service factor **FS'** which equals the ratio between T<sub>2M</sub> (gear unit rated torque reported in the catalogue) and T<sub>2'</sub> (torque required by the application).*

Der **FS** Betriebsfaktor ermöglicht die annähernde Bestimmung der Anwendungsart. Dabei werden Art der Last (A, B, C), Betriebsstunden pro Tag (S/T) und Anzahl der Starts pro Stunde berücksichtigt. Der so ermittelte Koeffizient sollte dem Betriebsfaktor **FS'**, der sich aus dem Verhältnis zwischen Nenndrehmoment des Getriebes T<sub>2M</sub> (s. Katalog) und dem für die Anwendung erforderlichen Drehmoment T<sub>2'</sub> ergibt, entweder entsprechen oder niedriger liegen.

$$FS' = \frac{T_{2M}}{T_2'} > FS$$

I valori di **FS** indicati nella tab. 2, sono relativi all'azionamento con motore elettrico; se utilizzato un motore a scoppio, si dovrà tenere conto di un fattore di moltiplicazione 1.3 se a più cilindri e 1.5 se monocilindro. Se il motore elettrico applicato è autofrenante, considerare un numero di avviamenti doppio di quello effettivamente richiesto.

***FS** values reported in table 2 refer to a drive unit equipped with an electric motor. If an internal combustion engine is used, a multiplication factor of 1.3 must be applied for a several-cylinder engine, 1.5 for a single-cylinder engine. If the electric motor is self-braking, consider twice the number of starts-up than those actually required.*

Die **FS** Werte, die in Tabelle 2 angegeben werden, beziehen sich auf den Antrieb mit Elektromotor; falls ein Explosionsmotor verwendet wird, ist ein Multiplikationsfaktor von 1.3 für Mehrzylindermotor und von 1.5 für Einzylindermotor zu berücksichtigen. Falls der verwendete Elektromotor ein Bremsmotor ist, so ist die Zahl der tatsächlich erforderlichen Startvorgänge doppelt zu zählen.

Tab. 2

Classe di carico <i>Load class</i> Lastklasse	h/gg <i>h/d</i> St./Tag	N. AVVIAMENTI/ORA / N. START-UP/HOUR / ANZAHL DER STARTVORGÄNGE PRO STUNDE								
		2	4	8	16	32	63	125	250	500
<b>A</b>	4	0.8	0.8	0.9	0.9	1.0	1.1	1.1	1.2	1.2
	8	1.0	1.0	1.1	1.1	1.3	1.3	1.3	1.3	1.3
	16	1.3	1.3	1.3	1.3	1.5	1.5	1.5	1.5	1.5
	24	1.5	1.5	1.5	1.5	1.8	1.8	1.8	1.8	1.8
APPLICAZIONI / APPLICATIONS / ANWENDUNGEN										
Agitatori per liquidi puri Alimentatori per fornaci Alimentatori a disco Filtri di lavaggio con aria Generatori Pompe centrifughe Trasportatori con carico uniforme			<i>Pure liquid agitators</i> <i>Fournace feeders</i> <i>Disc feeders</i> <i>Air laundry filters</i> <i>Generators</i> <i>Centrifugal pumps</i> <i>Uniform load conveyors</i>			Rührwerke für reine Flüssigkeiten Beschickungsvorrichtungen für Brennöfen Telleraufgeber Spülluftfilter Generatoren Kreiselpumpen Förderer mit gleichmäßig verteilter Last				

Classe di carico <i>Load class</i> Lastklasse	h/gg <i>h/d</i> St./Tag	N. AVVIAMENTI/ORA / N. START-UP/HOUR / ANZAHL DER STARTVORGÄNGE PRO STUNDE								
		2	4	8	16	32	63	125	250	500
<b>B</b>	4	1.0	1.0	1.0	1.0	1.3	1.3	1.3	1.3	1.3
	8	1.3	1.3	1.3	1.3	1.5	1.5	1.5	1.5	1.5
	16	1.5	1.5	1.5	1.5	1.8	1.8	1.8	1.8	1.8
	24	1.8	1.8	1.8	1.8	2.2	2.2	2.2	2.2	2.2
APPLICAZIONI / APPLICATIONS / ANWENDUNGEN										
Agitatori per liquidi e solidi Alimentatori a nastro Argani con medio servizio Filtri con pietre e ghiaia Viti per espulsione acqua Flocculatori Filtri a vuoto Elevatori a tazze Gru			<i>Liquid and solid agitators</i> <i>Belt conveyors</i> <i>Medium service winches</i> <i>Stone and gravel filters</i> <i>Dewatering screws</i> <i>Flocculator</i> <i>Vacuum filters</i> <i>Bucket elevators</i> <i>Cranes</i>			Rührwerke für Flüssigkeiten und Feststoffe Bandförderer Mittlere Winden Filter mit Steinen/Kies Abwasserschnecken Flockvorrichtungen Vakuumfilter Becherwerke Kräne				

Classe di carico <i>Load class</i> Lastklasse	h/gg <i>h/d</i> St./Tag	N. AVVIAMENTI/ORA / N. START-UP/HOUR / ANZAHL DER STARTVORGÄNGE PRO STUNDE								
		2	4	8	16	32	63	125	250	500
<b>C</b>	4	1.3	1.3	1.3	1.3	1.5	1.5	1.5	1.5	1.5
	8	1.5	1.5	1.5	1.5	1.8	1.8	1.8	1.8	1.8
	16	1.8	1.8	1.8	1.8	2.2	2.2	2.2	2.2	2.2
	24	2.2	2.2	2.2	2.2	2.5	2.5	2.5	2.5	2.5
APPLICAZIONI / APPLICATIONS / ANWENDUNGEN										
Argani per servizio pesante Estrusori Calandre per gomma Presse per mattoni Piallatrici Mulini a sfera			<i>Heavy duty hoists</i> <i>Extruders</i> <i>Crusher rubber calenders</i> <i>Brick presses</i> <i>Planing machine</i> <i>Ball mills</i>			Winden für schwere Lasten Extruder Gummikalander Ziegelpresen Hobelmaschinen Kugelmühle				

### 1.3 Selezione

Determinare la potenza in entrata  $P'$  (in base alla coppia  $T_2$  richiesta dall'applicazione) con la seguente formula:

### 1.3 Selection

Calculate input power  $P'$  (on the basis of the torque  $T_2$  required by the application), using the following formula:

$$P' = \frac{T_2' \cdot n_2}{9550 \cdot \eta} \quad [\text{kW}]$$

Calcolare il rapporto di trasmissione con la relazione:

Calculate the transmission ratio with the following equation:

$$i_n = \frac{n_1}{n_2}$$

Scegliere il fattore di servizio FS dell'applicazione nella Tab. 2.

Select the service factor FS of the application in Table 2.

### 1.3 Wahl

Bestimmen Sie die Antriebsleistung  $P'$  (je nach dem bei der Anwendung erforderlichen Drehmoment  $T_2$ ) mit Hilfe der folgenden Formel:

Berechnen Sie das Untersetzungsverhältnis mit Hilfe der Gleichung:

Wählen Sie den Betriebsfaktor FS der Anwendung aus der Tabelle 2 aus.

#### Scelta riduttore

A)  $n_1 = 1400 \text{ min}^{-1}$

Si sceglierà nelle tabelle delle prestazioni dei riduttori un gruppo che in corrispondenza di un rapporto prossimo a quello calcolato ammetta una potenza:

#### Selecting a gearbox

A)  $n_1 = 1400 \text{ min}^{-1}$

Consult the gear unit efficiency table; select a group whose ratio is close to the calculated ratio and which permits power:

#### Wahl des Getriebes

A)  $n_1 = 1400 \text{ min}^{-1}$

Aus der Tabelle der Leistungen der Untersetzungsgetriebe wählt man eine Baugruppe aus, die ein ähnliches Untersetzungsverhältnis zu dem berechneten Wert aufweist und die die folgende Leistung zulässt:

$$P \geq P' \times \text{FS}$$

B)  $n_1 \neq 1400 \text{ min}^{-1}$

Si dovrà effettuare la scelta come nel caso precedente però in base ad una potenza  $P_c$  corretta con i coefficienti riportati nelle tabelle relative ad ogni tipologia di riduttore verificando la relazione:

B)  $n_1 \neq 1400 \text{ min}^{-1}$

Make the selection as described above but on the basis of power  $P_c$  corrected by the coefficients reported in the tables. The following equation should be checked out:

B)  $n_1 \neq 1400 \text{ min}^{-1}$

Die Wahl wird wie im obigen Fall ausgeführt, allerdings auf der Basis einer Leistung  $P_c$ , die mit den Koeffizienten korrigiert wurde. Dabei ist das folgende Verhältnis zu überprüfen:

$$P_c \geq P' \times \text{FS}$$

#### Scelta del motoriduttore

C)  $n_1 = 1400 \text{ min}^{-1}$  e  $\text{FS} = 1$

Si cercherà nelle tabelle della prestazioni dei motoriduttori un gruppo la cui potenza  $P_1$  corrisponda alla  $P'$  calcolata.

D)  $n_1 \neq 1400 \text{ min}^{-1}$  o se il fattore  $\text{FS} \neq 1$

La scelta dovrà essere effettuata come al punto A) verificando che la grandezza del motore da installare sia compatibile con quelle ammesse dal riduttore (IEC); ovviamente la potenza installata dovrà corrispondere al valore  $P'$  richiesto.

#### Selecting a gearmotor

C)  $n_1 = 1400 \text{ min}^{-1}$  and  $\text{FS} = 1$

Consult the gear motor efficiency table and select a group having power  $P_1$  corresponding to calculated  $P'$ .

D)  $n_1 \neq 1400 \text{ min}^{-1}$  or  $\text{FS} \neq 1$

Follow the instructions at point A), checking that the size of the motor to be installed is compatible with the gear unit (IEC); obviously, installed power must correspond to the required  $P'$  value.

#### Wahl des Getriebemotors

C)  $n_1 = 1400 \text{ min}^{-1}$  und  $\text{FS} = 1$

In den Leistungstabellen der Getriebemotoren sucht man eine Baugruppe, deren Leistung  $P_1$  der berechneten Leistung  $P'$  entspricht.

D)  $n_1 \neq 1400 \text{ min}^{-1}$  oder  $\text{FS} \neq 1$

Die Auswahl wird wie unter A) getroffen, wobei zu überprüfen ist, ob die Größe des zu installierenden Motors mit dem Untersetzungsgetriebe kompatibel ist (IEC); selbstverständlich muß die Einbauleistung dem erforderlichen Wert  $P'$  entsprechen.

## Verifiche

Verificare che i carichi radiali agenti sugli alberi rientrino nei valori ammissibili riportati nelle relative tabelle.

Tali valori ( $F_{R2}$ ) si riferiscono a carichi che agiscono a metà sporgenza dell'albero, per cui se il punto di applicazione è diverso, è necessario effettuare il calcolo dei nuovi valori ammissibili alla distanza ( $y$ ) desiderata.

Analogamente a quanto precisato sopra, anche i carichi assiali dovranno essere oggetto di verifica confrontandoli con i valori delle relative tabelle.

## Sovraccarichi

Durante il normale funzionamento del riduttore è ammesso un sovraccarico istantaneo di emergenza pari al 100% della coppia indicata  $T_2$ .

Se si temono sovraccarichi frequenti o superiori è indispensabile prevedere degli opportuni dispositivi per la limitazione della coppia.

## Ingranaggi

Il calcolo a durata ed a fatica degli ingranaggi viene eseguito secondo la norma ISO 6336 e ISO 10300, considerando l'impiego di olio sintetico.

## Check-list

*Check that the radial loads on the shafts fall within to the admissible values reported in the relative tables.*

*Reported values ( $F_{R2}$ ) refer to loads which affect the shaft at the half-way point of its projection; if the point of application is different, it is necessary to calculate the new admissible values at the desired distance ( $y$ ).*

*In keeping with the above guidelines, axial loads should also be checked against the values reported in the relative tables.*

## Overloads

*An emergency momentary overload up to 100% of  $T_2$  torque is allowed during standard operation of the gearbox.*

*Should frequent or higher overloads be expected, it is necessary to install torque limiting devices.*

## Gears

*Life and fatigue of the gears are calculated in compliance with ISO 6336 and ISO 10300. Calculations refer to utilization of synthetic oil*

## Überprüfungen

Es ist zu überprüfen, ob die auf die Wellen wirkenden Radiallasten unter den in der Tabellen angegebenen zulässigen Werten fallen.

Werte beziehen sich auf Lasten, die in der  $F_{R2}$  Mitte der herausragenden Welle wirken; bei verschiedenem Ansatzpunkt ist es daher erforderlich, die neuen, beim gewünschten Abstand ( $y$ ) zulässigen Werte zu berechnen.

Ähnlich wie oben, müssen auch Axialbelastungen überprüft werden, indem man sie mit den Werten der jeweiligen Tabellen vergleicht.

## Überbelastungen

Eine augenblickliche Notfall-Überbelastung zu 100% des  $T_2$  Drehmoments darf während Getriebestandardbetrieb eintreten.

Falls häufige und höhere Überlastungen erwartet werden, sind die entsprechenden Vorrichtungen zur Begrenzung des Drehmoments anzubringen.

## Räderwerk

Dauer und Belastung werden gemäß ISO 6336 und ISO 10300 berechnet. Dabei wird die Anwendung von synthetischem Öl berücksichtigt

## 1.4 Potenza Termica

Nelle tabelle riportate nelle sezioni relative ad ogni tipologia di riduttore sono indicati i valori della potenza termica nominale  $P_{t0}$  (kW). Tale valore rappresenta la potenza massima applicabile all'entrata del riduttore, in servizio continuo a temperatura ambiente di 30°C, così che la temperatura dell'olio non oltrepassi il valore di 95°C, valore massimo ammesso nel caso di prodotti standard.

**Il valore di  $P_{t0}$  non deve essere preso in considerazione** se il funzionamento è continuo per un massimo di 1.5 ore seguito da pause di durata sufficiente (circa 1 – 2 ore) a ristabilire nel riduttore la temperatura ambiente.

I valori di  $P_{t0}$  devono essere corretti tramite i seguenti coefficienti, così da considerare le reali condizioni di funzionamento, ottenendo i valori di potenza termica corretta  $P_{tc}$ .

## 1.4 Thermal power

*The different sections dedicated to each type of gearbox contain tables reporting the values of rated thermal power  $P_{t0}$  (kW). Reported values correspond to the maximum admissible power at gearbox input, on continuous duty and with ambient temperature of 30°C, so that oil temperature does not exceed 95°C, which is the max. admissible value for standard products.*

**$P_{t0}$  value should not be taken into account** in case of continuous duty for max. 1.5 hours followed by pauses which are long enough to bring the gearbox back to ambient temperature (roughly 1 – 2 hours).

*In order to comply with the actual operating conditions,  $P_{t0}$  values should be corrected with the following coefficients, thus obtaining the values of corrected thermal power  $P_{tc}$ .*

## 1.4 Thermische Leistung

Für jeden Getriebetyp gibt es Tabellen, die die Nennwerte der thermischen Leistung  $P_{t0}$  (kW) angeben. Die angegebenen Werte stellen die max. anwendbare Antriebsleistung der Getriebe im Dauerbetrieb mit einer Umgebungstemperatur von max. 30°C dar, sodass die Öltemperatur unter 95°C bleibt (max. Wert für Standardprodukte).

**$P_{t0}$  Wert darf nicht betrachtet werden**, falls Dauerbetrieb max. 1.5 Stunden dauert und von Stillstand gefolgt wird, der lang genug ist, damit das Getriebe zur Umgebungstemperatur zurück kommt. (ungefähr 1 – 2 Stunden).

$P_{t0}$  Werte sollen durch die folgenden Koeffizienten verbessert werden, Damit die realen Betriebsbedingungen wirklich in Betracht gezogen werden. Mit der folgenden Formel erhält man die Werte der korrekten thermischen Leistung  $P_{tc}$ .

$$P_{tc} = P_{t0} \cdot ft \cdot fv \cdot fu \text{ (kW)}$$

Dove:

**ft** = coefficiente di temperatura (v. tab. 3)

Where:

**ft** = temperature coefficient (see table 3)

Dabei ist:

**ft** = Temperaturkoeffizient (siehe Tabelle 3)

Tab. 3

Tc (°C)	0	5	10	15	20	25	30	35	40	45	50
<b>ft</b>	1.46	1.38	1.31	1.23	1.15	1.1	1	0.92	0.85	0.77	0.69

(Dove Tc (°C) è la temperatura ambiente)

(Tc (°C) is the ambient temperature)

(Tc (°C) ist die Umgebungstemperatur)

**fv** = coefficiente di ventilazione

fv= 1.45 con ventilazione forzata efficace con ventola dedicata

fv= 1.25 con ventilazione forzata secondaria ad altri dispositivi (pulegge, ventole motore, ecc.)

fv= 1 refrigerazione naturale (situazione standard)

fv= 0.5 in ambiente chiuso e ristretto (carter)

**fv** = cooling coefficient

fv= 1.45 forced cooling with specific fan

fv= 1.25 forced cooling secondary to other devices (pulleys, motor fans, etc)

fv= 1 natural cooling (standard)

fv= 0.5 in a closed and narrow environment

**fv** = Luftkühlungskoeffizient

fv= 1.45 Drucklüftung mit Sonderlüfterrad

fv= 1.25 Drucklüftung nebensächlich zu anderen Vorrichtungen (Scheiben, Motorlüfterräder, usw.)

fv= 1 natürliche Lüftung (Standard)

fv= 0.5 in engem und geschlossenem Raum

**fu** = coefficiente di utilizzo (v. tab. 4)

**fu** = utilization coefficient (see table 4)

**fu** = Verwendungskoeffizient (siehe Tabelle 4)

Tab. 4

Dt (min)	10	20	30	40	50	60
<b>fu</b>	1.6	1.35	1.2	1.1	1.05	1

Dove Dt sono i minuti di funzionamento in un'ora

Dt is minutes of operation per hour

Dt steht für Betriebsminuten pro Stunde

### 1.5 Verifica del dispositivo antiritorno

Dopo aver correttamente selezionato il riduttore, occorre verificare se il valore del momento torcente  $T_{2M}$  max garantito all'asse uscita del riduttore dal dispositivo antiritorno, considerate le reali condizioni di esercizio, è sufficiente a garantire il buon funzionamento dell'applicazione. Deve pertanto essere verificata la seguente relazione:

### 1.5 Check of back stop device

After having selected the gearbox it is necessary to check whether the max. output torque  $T_{2M}$  max guaranteed by the backstop device, in view of the actual operating conditions, is sufficient to ensure the good functioning of the application. The following equation has to be checked out:

### 1.5 Prüfung der Rücklaufsperr

Nach der Wahl des Getriebes muss sichergestellt werden, dass das von der Rücklaufsperr garantierte Abtriebsdrehmoment  $T_{2M}$  max hoch genug ist, damit der korrekte Ablauf der Applikation unter Berücksichtigung der wirklichen Betriebsbedingungen gewährleistet wird. Die folgende Relation ist festzustellen:

$$T_{2M} \max = T_{2NOM} \cdot fc \cdot fa \cdot ft \quad (1)$$

Dove:

**T<sub>2NOM</sub>** [Nm]: è il momento torcente che deve essere garantito all'asse uscita del riduttore, nell'istante in cui viene interrotta la trasmissione del moto, affinché sia soddisfatta la condizione di irreversibilità del moto. **T<sub>2NOM</sub>** dipende dalle specifiche dell'applicazione e deve essere valutato volta per volta.

**fc**: fattore di carico

fc=1 in caso di funzionamento regolare  
fc=1.3 in caso di funzionamento con urti moderati

fc=1.8 in caso di funzionamento con forti urti

Where:

**T<sub>2NOM</sub>** [Nm]: is the torque that must be guaranteed at gearbox output when motion transmission is stopped, in order that motion irreversibility is ensured. **T<sub>2NOM</sub>** depends on application features and should be assessed each time.

**fc**: load factor

fc=1 in case of standard operation  
fc=1.3 in case of operation with moderate shocks

fc=1.8 in case of operation with heavy shocks

Dabei ist:

**T<sub>2NOM</sub>** [Nm]: Drehmoment, das am Getriebebetrieb garantiert werden muss, wenn die Übertragung der Bewegung stoppt, damit Irreversibilität gewährleistet wird. **T<sub>2NOM</sub>** hängt ab von den Merkmalen der Applikation, d. h. **T<sub>2NOM</sub>** muss jeweils bewertet werden.

**fc**: Last-Faktor

fc=1 bei Standardbetrieb  
fc=1.3 bei Betrieb mit mäßigen Stößen  
fc=1.8 bei Betrieb mit starken Stößen

#### NOTA:

Per funzionamento regolare si intende il caso in cui il dispositivo antiritorno, in attesa della ripresa della normale attività del riduttore, mantiene la macchina ferma. Se invece, nel momento in cui il dispositivo antiritorno è azionato (quindi il riduttore è fermo), il carico in uscita aumenta di intensità si possono avere degli urti (moderati o forti).

#### NOTE:

By standard running we mean that the back stop device keeps the machine stationary, whilst awaiting the restart of the gearbox operation. On the contrary in case the back stop device is enabled (motionless gearbox) and the output load gets heavier, moderate or heavy shocks might occur.

#### ANMERKUNG:

Im Standardbetrieb wird der Abtrieb bei einem Maschinenstopp durch die Rücklaufsperr blockiert. Ein erneuter Start löst die Rücklaufsperr wieder. Treten im Stillstand mässige oder starke Laststösse auf, müssen diese bei der Getriebeauslegung berücksichtigt werden.

**fa:** fattore di applicazione, ricavabile dalla seguente tabella (tab. 5) in funzione del numero di inserzioni/ora e dal numero di ore di funzionamento al giorno del riduttore

**fa:** application factor, as shown in the following table (tab. 5), depending on the number of backstop device insertions per hour and the number of gearbox operating hours per day.

**fa:** Anwendungsfaktor, wie es in der folgenden Tabelle (Tab.5) angegeben wird. Der Anwendungsfaktor hängt von der Zahl der Einschaltungen der Rücklaufsperr pro Stunde und von Betriebsstunden des Getriebes pro Tag ab.

Tab. 5

	n° INSERZIONI / h - INSERTIONS / H - NR. EINSCHALTUNGEN / STUNDE					
h/gg - h/d - St./Tag	2	4	8	16	32	63
8	1	1	1.1	1.2	1.3	1.4
16	1.3	1.3	1.4	1.5	1.6	1.7
24	1.5	1.5	1.6	1.7	1.8	1.9

**ft:** fattore di temperatura ricavabile dalla seguente tabella (tab.6) in funzione della temperatura ambiente di funzionamento.

**ft:** temperature factor, as shown in the following table (tab. 6) depending on ambient temperature during gearbox operation.

**ft:** Temperaturfaktor, wie es in der folgenden Tabelle (Tab.6) angegeben wird. Der Temperaturfaktor hängt von der Umgebungstemperatur während des Getriebebetriebs ab.

Tab. 6

Tamb (°C)	-20°	-10°	0°	10°	20°	30°	40°	50°
ft	1.2	1.15	1.1	1.05	1	1.03	1.05	1.10

**Se la relazione (1) a pag. 6 non risulta essere verificata** si prenda in considerazione la possibilità o di variare il rapporto di riduzione, individuando una alternativa migliore, o di passare alle grandezze di riduttori successive.

**If the result of the calculation does not correspond to the equation (1) at page 6,** either the ratio has to be modified or a bigger size of gearbox has to be selected.

**Falls das Resultat nicht der Relation (1) entspricht (Seite 6),** muss entweder das Untersetzungsverhältnis oder die Größe des Getriebes geändert werden.

Nel caso in cui il riduttore, provvisto di dispositivo antiritorno, si trovi ad operare ad una temperatura ambiente minore di 0°C il riduttore può essere fornito, a seconda del rapporto di riduzione, in esecuzione speciale (con camera stagna) così da migliorare il funzionamento del dispositivo. Per quanto riguarda quest'ultima soluzione si contatti il servizio tecnico Tramec.

*If the ambient temperature is below 0°C, the gearbox with backstop device can be supplied in the special execution (with tight chamber) which improves the functioning of the backstop device. Please contact Tramec Technical Dept. for further information.*

Liegt die Umgebungstemperatur unter 0°C, wird empfohlen, die Sonderausführung des Getriebes (mit Dichtkammer) zu benutzen, damit die Rücklaufsperr am besten funktioniert. Für weitere Auskünfte darüber soll man sich mit Tramec technischen Büro in Verbindung setzen.

## 1.6 Lubrificazione

I cuscinetti dell'albero veloce vengono sempre lubrificati con grasso a base sintetica; altri cuscinetti vengono lubrificati solo se la posizione di montaggio non ne garantisce la corretta lubrificazione.

Una scelta oculata del tipo di lubrificante, in funzione delle condizioni operative e ambientali, consente ai riduttori di raggiungere le prestazioni ottimali. Le prestazioni dei riduttori indicate nelle tabelle dei dati tecnici sono state calcolate considerando l'impiego di olio sintetico.

### VISCOSITA'

E'uno dei parametri più importanti da considerare nella scelta di un olio ed è influenzabile da diversi parametri quali velocità, temperatura. Riportiamo sinteticamente le valutazioni generali per la scelta della giusta viscosità:

#### Viscosità alta

Usare per basse velocità di rotazione e/o temperature alte. (Una viscosità troppo bassa in queste condizioni operative causa una usura precoce).

#### Viscosità bassa

Usare per alte velocità di rotazione e/o temperature basse. (Una viscosità troppo elevata provoca diminuzione del rendimento e surriscaldamento).

### ADDITIVI

In tutti gli oli minerali sono contenuti degli additivi antiusura, EP (più o meno energici), antiossidanti ed antischiuma. E' opportuno assicurarsi che essi siano blandi e non aggressivi nei confronti delle guarnizioni.

### BASE DELL'OLIO

Può essere minerale o sintetica. L'olio sintetico, compensa il costo più elevato con una serie di vantaggi:

- minor coefficiente d'attrito (quindi migliore rendimento)
- migliore stabilità nel tempo (possibile lubrificazione a vita)
- migliore indice di viscosità (migliore adattabilità alle varie temperature).

L'olio a base minerale come vantaggi ha il minore costo e un migliore comportamento in rodaggio.

## 1.6 Lubrication

*The bearings mounted on the input shaft are supplied with grease, synthetic base; the other bearings are lubricated only if the mounting position does not assure a correct lubrication.*

*Choose the lubricant according to operating and ambient conditions in order to ensure high gear unit performance. Performance data, as shown in the specifications tables, refer to utilization of synthetic oil.*

### VISCOSITY

*It is the most important parameter to be considered when selecting an oil; it depends on various factors such as speed and temperature. Following are general guidelines for choosing the correct viscosity:*

#### High viscosity

*To be used for low rotation speed and/or high temperatures. (Under these operating conditions a low viscosity causes premature wear).*

#### Low viscosity

*To be used for high rotation speed and/or low temperatures. (High viscosity reduces efficiency and causes overheating).*

### ADDITIVES

*All mineral oils contain additives to protect against wear, EP (more or less strong), anti-oxidizing and anti-frothing. It is advisable to make sure that the action of such additives is bland and not too aggressive on the seals.*

### OIL BASE

*May be mineral or synthetic. Synthetic oil compensates for the higher cost with a series of advantages :*

- lower friction coefficient (consequently improved efficiency)*
- better stability over time (possible life lubrication)*
- better viscosity index (more adaptable to various temperatures).*

*Mineral-base oils offer the advantages of costing less and performing better during the running-in period.*

## 1.6 Ölschmierung

Die Kugellager auf der Eingangswelle werden immer mit synthetischem Fett geliefert. Falls die Montage keine korrekte Schmierung gewährleistet, dann werden die restlichen Lager mit Schmiermittel geliefert.

Das Untersetzungsgetriebe wird optimal arbeiten, wenn das richtige Schmiermittel je nach Betriebs- und Umgebungsbedingungen sorgfältig ausgewählt wird. Daten über Getriebeleistung, wie es in den Tabellen der technischen Daten angegeben wird, beziehen sich auf Schmierung mit synthetischem Öl.

### VISKOSITÄT

Die Viskosität ist eines der wichtigsten Merkmale, die bei der Auswahl des richtigen Öls zu beachten sind; sie wird von verschiedenen Parametern wie Geschwindigkeit und Temperatur beeinflusst. Im folgenden fassen wir die wichtigsten allgemeinen Hinweise für die Wahl der richtigen Viskosität zusammen:

#### Hohe Viskosität

Geeignet für niedrige Drehzahlen bzw. hohe Temperaturen. (Eine zu geringe Viskosität verursacht unter diesen Betriebsbedingungen frühen Verschleiß).

#### Geringe Viskosität

Geeignet für hohe Drehzahlen bzw. niedrige Temperaturen. (Eine zu hohe Viskosität führt in diesem Fall zu einer Verringerung des Wirkungsgrades und zur Überhitzung).

### ZUSAETZE















Alle Mineralöle enthalten Antiverschleiß-Zusätze, EP (mehr oder weniger stark), Oxydationsschutzmittel und Mittel gegen Schaumbildung. Es soll sichergestellt werden, daß diese Zusätze schwach sind und die Dichtungen nicht angreifen.

### ÖLGRUNDLAGE

Es kann sich dabei um Mineralöl oder synthetisches Öl handeln. Synthetisches Öl ist kostenintensiver, bietet jedoch viele Vorteile:

- geringerer Reibungskoeffizient (besserer Wirkungsgrad)
- höhere Stabilität über lange Zeit (lebenslange Schmierung möglich)
- besserer Viskositätsindex (passt sich besser an Temperaturschwankungen an).

Die Vorteile von Mineralöl sind die niedrigeren Kosten und das bessere Einfahrverhalten.

ISO VG	OLIO MINERALE / MINERAL OIL / MINERALE			OLIO SINTETICO / SYNTHETIC OIL / SYNTETISCHES ÖL					
	460	320	220	460	320	220	150		
Temperatura ambiente Amb. Temp. Tc (°C) Umgebungstemperatur	5° a 45°	0° a 40°	-5° a 35°	-15° a 100°	-20 a 90°	-25° a 80°	-30° a 70°		
FORNITORE / MANUFACTURER / HERSTELLER	MINERALE / MINERAL / MINERAL								
	SHELL		Omala OIL 460	Omala OIL 320	Omala OIL 220				
	BP		Energol GRXP 460	Energol GRXP 320	Energol GRXP 220				
	TEXACO		Meropa 460	Meropa 320	Meropa 220				
	CASTROL		Alpha SP 460	Alpha SP 320	Alpha SP 220				
	KLUBER		Lamora 460	Lamora 320	Lamora 220				
	MOBIL		Mobilgear 634	Mobilgear 632	Mobilgear 630				
	Tecnologia PAG (polialcoliglicoli) / PAG Technology (polyalkyleneglycol) / PAG (Polyalkylglykole)								
	SHELL					Omala S4 WE 460	Omala S4 WE 320	Omala S4 WE 220	Omala S4 WE 150
	BP					Energol SGXP460	Energol SGXP320	Energol SGXP220	Enersyn SG 150
	TEXACO					Synlube CLP 460	Synlube CLP 320	Synlube CLP 220	
	AGIP						Agip Blasias S 320	Agip Blasias S 220	Agip Blasias S 150
	Tecnologia PAO (polialcoliolefini) / PAO Technology (polyalphaolefin) / PAO (Polyalphaolefine)								
	SHELL					Omala OIL RL/HD 460	Omala OIL RL/HD 320	Omala OIL RL/HD 220	Omala OIL RL/HD 150
	CASTROL					Alpha Synt 460	Alpha Synt 320	Alpha Synt 220	Alpha Synt 150
	KLUBER					Synteso D460 EP	Synteso D320 EP	Synteso D220 EP	Synteso D150 EP
MOBIL					SHC 634	SHC 632	SHC 630	SHC 629	

### 1.7 Installazione

Montare il riduttore in modo tale da eliminare qualsiasi vibrazione.

Curare particolarmente l'allineamento del riduttore con il motore e la macchina da comandare interponendo dove è possibile giunti elastici od autoallineanti.

Quando il riduttore è sottoposto a sovraccarichi prolungati, urti o pericoli di bloccaggio, installare salvamotori, limitatori di coppia, giunti idraulici od altri dispositivi similari.

Fare attenzione a non superare i valori consentiti di carico radiale ed assiale che agiscono sugli alberi veloce e lento.

Assicurarsi che gli organi da montare sui riduttori siano lavorati con tolleranza **ALBERO ISO h6 FORO ISO H7.**

### 1.7 Installation

*Install the gearbox so that any vibration is eliminated.*

*Take special care with the alignment between the gear units, the motor and the driven machine, fitting flexible or self adjusting couplings wherever possible.*

*If the gearbox is subject to prolonged overloads, shocks or possible jamming, fit overload cutouts, torque limiters, hydraulic couplings or other similar devices.*

*Do not exceed allowed radial and axial loads on the input and output shafts.*

*Ensure that the components to be fitted on the gear units are machined with tolerance **SHAFT ISO h6 HOLE ISO H7.***

### 1.7 Einbau

Das Getriebe ist so zu montieren, daß Schwingungen ausgeschaltet werden.

Insbesondere ist auf die Fluchtung des Getriebes zum Motor und zur Maschine zu achten, wo möglich sind elastische oder selbstfluchtende Kupplungen anzubringen.

Wenn das Getriebe anhaltenden Überlasten, Schlägen oder Blockierungsgefahr ausgesetzt ist, sind Motorschalter, Drehmomentbegrenzer, hydraulische Kupplungen oder ähnliche Vorrichtungen anzubringen. Achten sie darauf, dass die zulässigen Radial- und Axialbelastungen an Antriebs- und Abtriebswelle nicht überschritten werden.

Achten Sie darauf, dass die am Getriebe montierten Elemente mit folgenden Toleranzen bearbeitet sind: **WELLE ISO h6, BOHRUNG ISO H7.**

Prima di effettuare il montaggio pulire e lubrificare le superfici al fine di evitare il pericolo di grippaggio e l'ossidazione da contatto.

Il montaggio va effettuato con l'ausilio di tiranti ed estrattori utilizzando il foro filettato posto in testa alle estremità degli alberi.

Durante la verniciatura si consiglia di proteggere il bordo esterno degli anelli di tenuta per evitare che la vernice ne essichi la gomma pregiudicando la tenuta del paraolio stesso.

Prima della messa in funzione della macchina accertarsi che la quantità di lubrificante e la posizione dei tappi di livello e sfiato siano conformi alla posizione di montaggio del riduttore e che la viscosità del lubrificante sia adeguata al tipo di carico.

Se il riduttore viene installato all'aperto si consiglia l'utilizzo del tappo di sfiato con valvola.

Tutti i riduttori e motoriduttori citati nel presente manuale sono destinati ad un impiego industriale con temperatura ambiente da -20°C a +40°C ad una altitudine max di 1000 m slm.

Per tutte le altre avvertenze consultare il manuale di "uso e manutenzione" scaricabile dal sito [www.tramec.it](http://www.tramec.it)

## 1.8 Rodaggio

Si consiglia di incrementare gradualmente nel tempo la potenza trasmessa oppure limitare il momento torcente resistente della macchina da comandare per le prime ore di funzionamento.

## 1.9 Manutenzione

Per i riduttori lubrificati con olio minerale dopo le prime 500 - 1000 ore di funzionamento sostituire l'olio effettuando, se possibile, un accurato lavaggio interno del riduttore.

Controllare periodicamente il livello del lubrificante ed effettuare il cambio dopo 4000 ore di funzionamento.

Se è utilizzato olio sintetico il cambio può essere effettuato dopo 12500 ore di funzionamento.

Quando il riduttore resta per lungo tempo inattivo in un ambiente con una elevata percentuale di umidità si consiglia di riempirlo completamente di olio.

Naturalmente al momento della successiva messa in funzione sarà necessario ripristinare il livello del lubrificante.

*Before assembling, clean and lubricate the surfaces to prevent seizure and contact oxidation.*

*Assembly is to be carried out with the aid of tie-rods and extractors, using the threaded hole at the shaft ends.*

*When painting, protect the outside edge of the oil seals to prevent the paint from drying the rubber and impairing sealing properties.*

*Before starting up the machine, check that the amount of lubricant and the position of filler and breather plugs are correct for the gear unit mounting position and that the lubricant viscosity is appropriate for the type of load.*

*If the gearbox is installed outdoors, we recommend the use of the breather plug with valve.*

*All reducers and gear motors mentioned in this catalog are intended for industrial use and operation at a ambient temperature between -20°C and +40°C, at an altitude of max. 1000 m above sea level.*

*For all other instructions check the "Use and Maintenance Manual" which can be downloaded from our web site [www.tramec.it](http://www.tramec.it)*

## 1.8 Running-in

*Increase the transmitted power gradually or limit the resistant torque of the driven machine for the first few operating hours.*

## 1.9 Maintenance

*Gear units lubricated with mineral oil, change the oil after the first 500 – 1000 operating hours and if possible thoroughly flush the inside of the gearbox.*

*Check the lubricant level regularly and change after 4000 operating hours. If synthetic oil is used the oil change may take place after 12500 running hours.*

*When the gearbox is left unused in a highly humid environment fill it completely with oil.*

*Importantly the oil must be returned to the operating level before the unit is used again.*

Vor der Montage sind die Flächen zu reinigen und zu schmieren, um Festfressen bzw. Kontaktoxidation zu vermeiden.

Die Montage erfolgt mit Hilfe von Zugstangen und Ausziehvorrichtungen unter Verwendung der Gewindebohrung vorn an den Wellenenden.

Während des Lackierens sollte der Außenrand der Dichtungsringe geschützt werden, um zu vermeiden, daß der Lack den Gummi austrocknet, was die Dichtungen beeinträchtigen könnte.

Bevor die Maschine in Betrieb genommen wird, ist sicherzustellen, daß sowohl die Schmiermittelmenge als auch die Position der Ölstand- und der Entlüftungsschraube der Montageposition des Getriebes entsprechen und daß die Schmiermittelviskosität der Belastungsart entspricht.

Die Anwendung einer Entlüftungsschraube mit Ventil wird empfohlen, wenn das Getriebe im Freien eingebaut wird.

Alle im vorliegenden Katalog angegebenen Getriebe und Getriebemotoren sind für industriellen Einsatz in einer Umgebungstemperatur von -20°C bis +40°C und in einer max. Höhe von 1000 m über dem Meeresspiegel vorgesehen.

Für weitere Anweisungen laden Sie die "Betriebs- und Instandhaltungsanweisung" aus unsere Webseite [www.tramec.it](http://www.tramec.it) herunter.

## 1.8 Einfahren

Es ist ratsam, die Leistung nur allmählich zu steigern oder das Widerstandsdrehmoment der Maschine in den ersten Betriebsstunden zu begrenzen.

## 1.9 Wartung

Bei mit Mineralöl geschmierten Getrieben ist nach den ersten 500 bis 1000 Betriebsstunden ein Ölwechsel durchzuführen, dabei sollte das Getriebeinnere möglichst ausgespült werden.

Von Zeit zu Zeit ist der Ölstand zu prüfen, alle 4000 Betriebsstunden sollte ein Ölwechsel stattfinden.

Bei Verwendung von Synthetiköl kann der Ölwechsel alle 12500 Betriebsstunden erfolgen.

Wenn das Getriebe lange Zeit in einem Raum mit hoher Luftfeuchtigkeit stillliegt, ist es ratsam, es ganz mit Öl zu füllen.

Wird es danach wieder in Betrieb genommen, so ist natürlich vorher der richtige Ölstand wiederherzustellen.

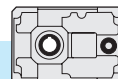

### 3.0 RIDUTTORI AD ASSI PARALLELI

### PARALLEL SHAFT GEARBOX

### PARALLELENGETRIEBE

3.1	Caratteristiche	<i>Characteristics</i>	Merkmale	46
3.2	Designazione	<i>Designation</i>	Bezeichnung	47
3.3	Velocità in entrata	<i>Input speed</i>	Antriebsdrehzahl	47
3.4	Rendimento	<i>Efficiency</i>	Wirkungsgrad	47
3.5	Potenza termica	<i>Thermal power</i>	Thermische Leistung	48
3.6	Dati tecnici	<i>Technical data</i>	Technische Daten	48
3.7	Momenti d'inerzia	<i>Moments of inertia</i>	Trägheitsmoment	50
3.8	Dimensioni	<i>Dimensions</i>	Abmessungen	54
3.9	Seconda entrata	<i>Second input</i>	Zweiter Antrieb	56
3.10	Accessori	<i>Accessories</i>	Zubehör	56
3.11	Giochi angolari	<i>Angular backlash</i>	Winkelspiel	59
3.12	Lubrificazione	<i>Lubrication</i>	Schmierung	60
3.13	Carichi radiali e assiali	<i>Radial and axial loads</i>	Radial- und Axialbelastungen	61
3.14	Lista parti di ricambio	<i>Spare parts list</i>	Ersatzteilliste	63

ZF..

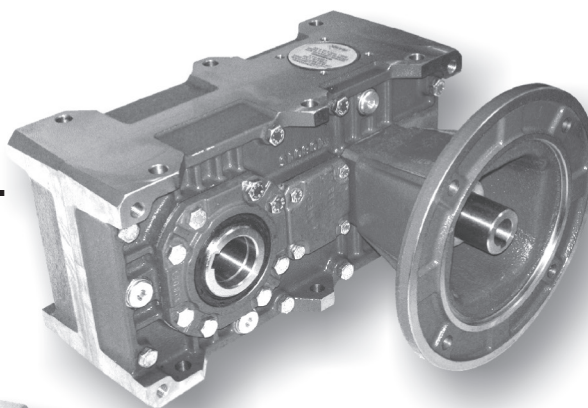

ZA..

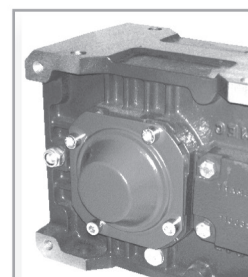
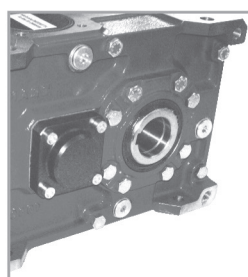
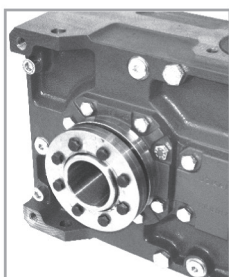
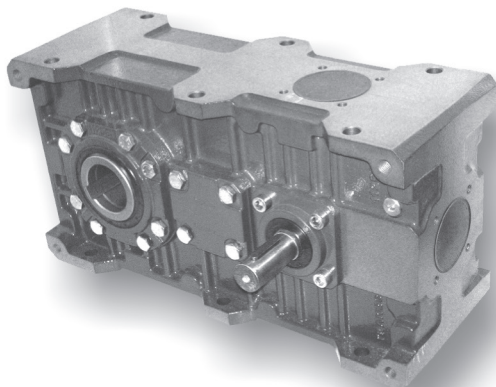

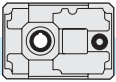

### 3.1 Caratteristiche

- Costruiti in 6 grandezze a una riduzione, 6 a 2 riduzioni e 6 grandezze a 3 riduzioni.
- Sono previsti due tipi di entrata: con albero entrata sporgente, con predisposizione attacco motore (campana e giunto).
- Il corpo riduttore in ghisa meccanica EN GJL 200 UNI EN 1561(71-180) o in ghisa sferoidale EN GJS 400-15U UNI EN 1563 (200-225), abbondantemente nervato all'interno e all'esterno per garantire la rigidità, è lavorato su tutti i piani per consentire un facile posizionamento; inoltre un'unica camera di lubrificazione garantisce una maggiore dissipazione termica e una migliore lubrificazione di tutti gli organi interni.
- Gli ingranaggi cilindrici, a dentatura elicoidale, sono costruiti in acciaio 16NiCr4, 18NiCrMo5 o 20MnCr5 UNI EN 10084 cementati e temprati, tutti rettificati entro la classe di qualità 6 della DIN 3962.
- L'utilizzo dei cuscinetti a rulli conici di qualità su tutti gli assi consente al riduttore di ottenere delle durate molto elevate e di sopportare dei carichi radiali e assiali esterni di notevole entità.
- L'albero lento cavo di serie in acciaio (disponibile a richiesta con calettatore), la possibilità di montare una flangia uscita sul fianco opposto all'albero entrata e la predisposizione per il montaggio del dispositivo antiritorno esaltano la versatilità di questi riduttori facilitandone l'installazione.
- Il corpo riduttore, le flange, le campane ed i coperchi vengono verniciati esternamente di colore BLU RAL 5010.

### 3.1 Characteristics

- *Built in 6 sizes with single reduction stage, in 6 sizes with two reduction stages and in 6 sizes with three reduction stages.*
- *Two input types are available : with projecting input shaft, with pre-engineered motor coupling (bell and joint).*
- *The gear unit body in engineering cast iron, EN GJL 200 UNI EN 1561 (71-180) or spheroidal graphite cast iron EN GJS 400-15U UNI EN 1563 (200-225) is internally and externally ribbed to guarantee rigidity, it is machined on all surfaces for easy positioning. The single lubrication chamber guarantees improved heat dissipation and better lubrication of all the internal components.*
- *The helical spur gears are built in 16NiCr4, 18NiCrMo5 or 20MnCr5 UNI EN 10084 quench-hardened and case-hardened steel, all ground according to quality 6 DIN 3962.*
- *The use of high-quality tapered roller bearings on all shafts ensures long life, and enables very high external radial and axial loads.*
- *The standard hollow output shaft made of steel (shrink disc available on request), the option of mounting an output flange on the side opposite to the input shaft the possibility of mounting a backstop device make these gear units extremely versatile and easy to install.*
- *Gearbox housing, flanges, bells and covers are externally painted with BLUE RAL 5010.*

### 3.1 Merkmale

- Erhältlich in 6 Größen mit einer Untersetzungsstufe, in 6 Größen mit 2 Untersetzungsstufen und 6 Größen mit drei Untersetzungsstufen.
- Zwei Antriebsarten (Getriebeeingang) sind lieferbar: Eingangswelle, Motoranbau mit Glocke und Kupplung, Motor Direktanbau.
- Das Getriebegehäuse ist aus Maschinenguss EN GJL 200 UN EN 1561 (71 – 180) oder aus Sphäroguss EN GJS 400-15U UNI EN 1563 (200-225), innen als auch außen mit Rippen versehen, die die Steifheit gewährleisten; die Bearbeitung aller Flächen ermöglicht eine leichte Positionierung. Eine einzige Schmierkammer gewährleistet eine höhere Wärmedissipation und eine bessere Schmierung aller inneren Elemente.
- Die Schrägstirnräder bestehen aus einseitig- und abschreckgehärtetem 16NiCr4, 18NiCrMo5-oder 20MnCr5-Stahl UNI EN 10084, geschliffen innerhalb Qualitätsklasse 6 der Spez. DIN 3962.
- An allen Achsen wurden Qualitäts-Kegelrollenlager verwendet, diese gewährleisten eine hohe Lebensdauer und das Aushalten sehr hoher äußerer Radial und Axialbelastungen.
- Die serienmäßige Abtriebshohlwelle aus Stahl (auf Wunsch mit Schrumpfscheibe erhältlich), die Möglichkeit der Montage eines Abtriebsflansches auf der Seite gegenüber der Antriebswelle und die Auslegung für die Montage der Rücklauf Sperre heben die Vielseitigkeit dieser Untersetzungsgetriebe hervor und erleichtern ihren Einbau.
- Getriebegehäuse, Flansche, Glocken und Deckel werden in BLAU RAL 5010 lackiert.

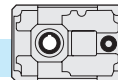

### 3.2 Designazione

### 3.2 Designation

### 3.2 Bezeichnung

Macchina Machine Maschine	Tipo entrata Input type Antriebsart	Grandezza Size Größe	Rotismo Gearing Räderwerk	Rapporto rid. Ratio Untersetzungsverhältnis	Predisposiz. Motor coupling Motoranschluss	Posizione di montaggio Mounting position Baulage	Flangia uscita Output flange Abtriebsflansch	Antirintorno Back-stop device Rücklaufsperre	Calettatore Shrink disk Schrumpfscheibe
<b>Z</b>	<b>A</b>	<b>112</b>	<b>B</b>	<b>10</b>	<b>P.A.M.</b>	<b>B3</b>	<b>FLD</b>	<b>CW</b>	<b>C.S.</b>
Riduttore ad assi paralleli Parallel shaft gear unit Parallelgetriebe		71 90 112 140 180 225	A	$i_n = 5 \div 250$	71 + 200	B3 V1 V3 VA VB		 AW	 C.S.
		80 100 125 160 180 200	B					 CW	 C.D.
		80 100 125 160 180 200	C						

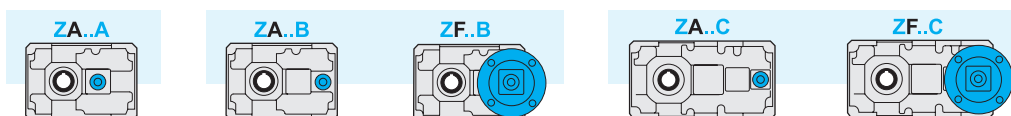

### 3.3 Velocità in entrata

### 3.3 Input speed

### 3.3 Antriebsdrehzahl

Tutte le prestazioni dei riduttori sono calcolate in base ad una velocità in entrata di 1400 min<sup>-1</sup>.

Tutti i riduttori ammettono velocità fino a 3000 min<sup>-1</sup> anche se è consigliabile, dove l'applicazione lo permette, utilizzare valori inferiori a 1400 min<sup>-1</sup>.

Nella tabella sottostante riportiamo i coefficienti correttivi della potenza in entrata P alle varie velocità riferita ad Fs = 1

All calculations of gear unit performance are based on an input speed of 1400 min<sup>-1</sup>. All gear units permit speed up to 3000 min<sup>-1</sup>, nevertheless it is advisable to keep below 1400 min<sup>-1</sup>, depending on application.

The table below reports input power P corrective coefficients at the various speeds, with Fs = 1.

Bei der Berechnung der Getriebeleistungen wurde eine Antriebsdrehzahl von 1400 min<sup>-1</sup> berücksichtigt.

Bei allen Getrieben sind Antriebsdrehzahlen bis 3000 min<sup>-1</sup> möglich; es ist jedoch ratsam, die Drehzahlen unter 1400 min<sup>-1</sup> zu halten, wenn die Anwendung es ermöglicht.

In der folgenden Tabelle finden Sie die Korrekturkoeffizienten für die Antriebsleistung P bei den verschiedenen Drehzahlen, bezogen auf Fs = 1.

Tab. 1

n <sub>1</sub> [min <sup>-1</sup> ]	3000	2800	2200	1800	1400	900	700	500
Pc (kW)	P x 1.9	P x 1.8	P x 1.48	P x 1.24	P x 1	P x 0.7	P x 0.56	P x 0.42

### 3.4 Rendimento

### 3.4 Efficiency

### 3.4 Wirkungsgrad

Il valore del rendimento dei riduttori può essere stimato con sufficiente approssimazione in base al numero di riduzioni, trascurando le variazioni non significative attribuibili alle varie grandezze e rapporti.

The efficiency value of the gear units can be estimated sufficiently well on the basis of the number of reduction stages, ignoring non-significant variations which can be attributed to the various sizes and ratios.

Der Wirkungsgrad des Getriebes kann mit ausreichender Annäherung aufgrund der Anzahl der Untersetzungsstufen ermittelt werden; dabei können die unwesentlichen Veränderungen, die auf die verschiedenen Größen und Untersetzungsverhältnisse zurückzuführen sind, außer acht gelassen werden.

η	Z...A	Z...B	Z...C
	0.97	0.95	0.93

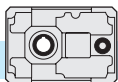

### 3.5 Potenza termica

I valori delle potenze termiche,  $P_{10}$  (kW), sono riportati nella tabella seguente, in funzione di grandezza, rapporto e velocità entrata del riduttore. I valori sono calcolati considerando l'utilizzo di olio sintetico ISO 320. Vedere paragrafo 1.4 per la scelta dei fattori correttivi.

### 3.5 Thermal power

The following table shows the values of thermal power  $P_{10}$  (kW) for each gearbox size on the basis of ratio and input speed. The values have been calculated considering the utilization of synthetic oil ISO 320. See chapter 1.4 for the corrective coefficients.

### 3.5 Thermische Leistung

Die folgende Tabelle enthält die Werte  $P_{10}$  der thermischen Leistung (kW) je nach Getriebegröße und abhängig von Untersetzung und von Drehzahlen am Getriebeantrieb. Die angegebenen Werte beziehen sich auf Schmierung mit synthetischem Öl ISO 320. Im Abschnitt 1.4 finden Sie die Korrekturkoeffizienten.

Tab. 2

Potenza Termica / Thermal power / Thermische Leistung $P_{10}$ [kW]												
	Z71A		Z90A		Z112A		Z140A		Z180A		Z225A	
$i_n$	1400	2800	1400	2800	1400	2800	1400	2800	1400	2800	1400	2800
5	5.5		10		16.5		28.5		49.6	47	93	67
6.3	5		8.6		14.5	15.4	24.8	25.8	-		-	
8	4		7		12	13	20.6	22	-		-	

	Z80B		Z100B		Z125B		Z160B		Z180B		Z200B	
$i_n$	1400	2800	1400	2800	1400	2800	1400	2800	1400	2800	1400	2800
8	-		-		-		-		55.7	53.4	75	65.2
10	7		12		20	21	37	37.6	49	48.3	69.4	61.8
12.5	6.5		10.8		18	19	32.7	33.4	43.6	43.4	61	55.3
16	5.8		9.8		16	17	29	30	36.6	40.2	51	54.7
20	5		8.7		14	15.5	25.6	28.6	33.2	36.7	48	51.7
25	5		7.8		12.8	14	23.4	26	30.5	33.5	43	46.8
31.5	4.6		7.4		12	13	21.6	23.7	27	29.5	39.4	42.4
40	4.2		7		11.2	12	20	21.6	25.2	27	-	
50	4		6.3		10.3	11	18.3	19.5	-		-	
63	3.5		5.7		9.4	10.2	16.6	18	-		-	

	Z80C		Z100C		Z125C		Z160C		Z180C		Z200C	
$i_n$	1400	2800	1400	2800	1400	2800	1400	2800	1400	2800	1400	2800
40	-		-		-		-		-		34.2	37.8
50	3.6		6		10	11	17.8	19.8	22.3	25.3	32.7	36
63	3.3		5.6		9.2	10.2	16.3	18.3	20.4	23.3	30.3	33
80	3.2		5.3		8.8	9.7	15.3	17	19.2	21.8	28.2	30.7
100	2.8		4.8		8	8.8	14	15.5	17.6	19.7	25.5	28.6
125	2.6		4.5		7.5	8.2	13	14.4	16.2	18.5	24	26.8
160	2.5		4.3		7.2	7.8	12.4	13.6	15.3	17	22.5	25
200	2.4		4		6.6	7.2	11.5	12.6	14.4	16	-	
250	2.4		3.8		6.3	7	11	12	13.4	14.7	-	

### 3.6 Dati tecnici

### 3.6 Technical data

### 3.6 Technische Daten

Z	$n_1 = 1400$			ZA	
	$i_n$	$i_r$	$n_2$ rpm	$T_{2M}$ Nm	P kW
71A	5	5.09	275	270	8.0
	6.3	6.10	230	210	5.2
	8	7.88	177	180	3.5
90A	5	5.09	275	590	17.5
	6.3	6.10	230	480	11.9
	8	7.88	177	360	6.9
112A	5	5.09	275	1200	35.6
	6.3	6.10	230	1150	28.5
	8	7.88	177	780	14.9
140A	5	5.09	275	2350	69.8
	6.3	6.10	230	2150	53.3
	8	7.88	177	2100	40.2
180A	5	5.09	275	4800	142.5
225A	5	4.82	291	8600	270



3.6 Dati tecnici

3.6 Technical data

3.6 Technische Daten

Z	n <sub>1</sub> = 1400			ZF				ZA	
	in	ir	n <sub>2</sub> rpm	T <sub>2</sub> Nm	P1 kW	FS'	IEC	T <sub>2M</sub> Nm	P kW
80B	10	10.20	137	119	1.8	4.3	71 80 90	510	7.7
	12.5	12.98	108	151	1.8	3.8		570	6.8
	16	15.56	90	181	1.8	3.5		630	6.3
	20	20.36	69	238	1.8	2.9		700	5.3
	25	24.40	57	285	1.8	2.5		700	4.4
	31.5	31.05	45	362	1.8	1.7		630	3.1
	40	37.21	38	434	1.8	1.3		560	2.3
	50	48.12	29	468	1.5	1.1		520	1.7
	63	62.23	22	444	1.1	1.2		520	1.3
80C	50	52.51	27	600	1.8	1.1	63 71 80 90	660	2.0
	63	62.91	22	599	1.5	1.1		680	1.7
	80	80.08	17	559	1.1	1.3		710	1.4
	100	105.52	13	736	1.1	1.0		740	1.1
	125	126.43	11	740	0.9	1.0		740	0.90
	160	160.91	9	561	0.55	1.2		680	0.70
	200	208.11	7	700	0.55	1.0		700	0.55
	250	249.36	6	585	0.37	1.2		720	0.48
	100B	10	10.20	137	364	5.5		2.9	71 80 90 100 112
12.5		12.98	108	462	5.5	2.5	1150	13.7	
16		15.56	90	554	5.5	2.3	1280	12.7	
20		20.36	69	723	5.5	2	1420	10.8	
25		24.40	57	875	5.5	1.6	1420	9.0	
31.5		31.05	45	1110	5.5	1.2	1290	6.4	
40		37.21	38	965	4	1.3	1220	5.1	
50		48.12	29	936	3	1.1	1060	3.4	
63		62.23	22	887	2.2	1.2	1060	2.6	
100C	50	51.93	27	593	1.8	2.2	71 80 90	1300	4.0
	63	62.22	23	710	1.8	1.9		1350	3.4
	80	79.19	18	904	1.8	1.6		1410	2.8
	100	103.67	14	1184	1.8	1.2		1470	2.2
	125	124.22	11	1418	1.8	1.0		1480	1.9
	160	158.10	9	1103	1.1	1.2		1360	1.4
	200	204.46	7	1400	1.1	1.0		1400	1.1
	250	244.99	6	1399	0.9	1.0		1440	0.9
	125B	10	10.20	137	608	9.2		3.5	80 90 100 112 132
12.5		12.98	108	774	9.2	3.0	2300	27.3	
16		15.56	90	927	9.2	2.7	2500	24.8	
20		20.36	69	1214	9.2	2.3	2850	21.6	
25		24.40	57	1455	9.2	2.0	2850	18.0	
31.5		31.05	45	1851	9.2	1.4	2550	12.7	
40		37.21	38	2218	9.2	1.1	2350	9.8	
50		48.12	29	2250	7.5	1.0	2250	7.5	
63		62.23	22	2218	5.5	1.0	2250	5.6	
125C	50	51.93	27	1810	5.5	1.5	71 80 90 100 112	2650	8.0
	63	62.22	23	2124	5.5	1.3		2760	7.0
	80	79.19	18	2714	5.5	1.0		2880	5.7
	100	103.67	14	2631	4	1.1		3000	4.6
	125	124.22	11	2364	3	1.3		3000	3.8
	160	158.10	9	2206	2.2	1.2		2720	2.7
	200	204.46	7	2800	2.2	1.0		2800	2.2
	250	244.99	6	2798	1.8	1.0		2880	1.9

Z	n <sub>1</sub> = 1400			ZF				ZA			
	in	ir	n <sub>2</sub> rpm	T <sub>2</sub> Nm	P1 kW	FS'	IEC	T <sub>2M</sub> Nm	P kW		
160B	10	10.20	137	1454	22	2.8	90 100 112 132 160 180	4000	60.5		
	12.5	12.98	108	1851	22	2.4		4500	53.5		
	16	15.56	90	2218	22	2.2		4900	48.6		
	20	20.36	69	2903	22	1.9		5500	41.7		
	25	24.40	57	3479	22	1.6		5500	34.8		
	31.5	31.05	45	4427	22	1.2		5200	25.8		
	40	37.21	38	4461	18.5	1.1		4700	19.5		
	50	48.12	29	3430	11	1.3		4300	13.8		
	63	62.23	22	4300	11	1.0		4300	11.0		
160C	50	51.93	27	3031	9.2	1.7	80 90 100 112 132	5130	15.6		
	63	62.22	23	3631	9.2	1.5		5350	13.6		
	80	79.19	18	4622	9.2	1.2		5570	11.1		
	100	103.67	14	5800	9.2	1.0		5800	9.2		
	125	124.22	11	5800	7.5	1.0		5800	7.5		
	160	158.10	9	5470	5.5	1.0		5470	5.5		
	200	204.46	7	5188	4	1.1		5600	4.3		
	250	244.99	6	4663	3	1.2		5760	3.7		
	180B	8	8.10	173	1155	22		4.4	80 90 100 112 132 160 180	5100	97.2
10		10.38	135	1480	22	3.8	5650	84.0			
12.5		12.54	112	1787	22	3.5	6200	76.3			
16		16.17	87	2305	22	2.9	6750	64.4			
20		20.73	68	2955	22	2.5	7300	54.4			
25		25.03	56	3569	22	2.1	7450	45.9			
31.5		31.05	45	4427	22	1.7	7550	37.5			
40		35.07	40	5000	22	1.5	7550	33.2			
180C		50	52.85	26	3085	9.2	2.4	80 90 100 112 132		7530	22.3
	63	63.33	22	3696	9.2	2.0	7560		18.8		
	80	76.48	18	4464	9.2	1.7	7700		15.9		
	100	94.89	15	5538	9.2	1.4	7650		12.7		
	125	127.43	11	7437	9.2	1.0	7680		9.6		
	160	158.10	9	7265	7.5	1.1	7830		8.1		
	200	197.46	7	6890	5.5	1.1	7870		6.3		
	250	244.99	6	7960	5.5	1.0	7960		5.5		
	200B	8	8.33	168	1619	30	4.6		132 160 180 200	7500	139
10		10.00	140	1945	30	4.2	8200	127			
12.5		12.29	114	2389	30	3.8	9000	113			
16		16.63	84	3233	30	3.0	9800	90.9			
20		19.97	70	3883	30	2.7	10600	81.9			
25		24.53	57	4769	30	2.3	11000	69.2			
31.5		30.04	47	5839	30	1.8	10700	55.0			
200C		40	42.41	33	5919	22	1.8	100 112 132 160 180		10900	40.5
		50	50.93	27	7108	22	1.5			11000	34.1
	63	62.55	22	8730	22	1.3	11350		28.6		
	80	76.59	18	10690	22	1.0	11050		22.7		
	100	101.68	14	11200	18.5	1.0	11200		18.5		
	125	124.87	11	11500	15	1.0	11500		15.0		
	160	152.91	9	10671	11	1.0	11200		11.6		

Verifica termica necessaria / Thermal rating needed / Thermische - Prüfung erforderlich

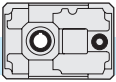

3.7 **Momenti d'inerzia** [Kg.cm<sup>2</sup>]  
(riferiti all'albero veloce in entrata)

3.7 **Moments of inertia** [Kg.cm<sup>2</sup>]  
(referred to input shaft)

3.7 **Trägheitsmoment** [Kg.cm<sup>2</sup>]  
(bez. Antriebswelle)

### ZA..A

<b>71A</b>	$i_n$	<b>ZA</b>
	5	1.11
	6.3	0.89
	8	0.64

<b>112A</b>	$i_n$	<b>ZA</b>
	5	10.00
	6.3	7.34
	8	5.22

<b>180A</b>	$i_n$	<b>ZA</b>
	5	91.58

<b>90A</b>	$i_n$	<b>ZA</b>
	5	3.35
	6.3	2.51
	8	1.79

<b>140A</b>	$i_n$	<b>ZA</b>
	5	28.25
	6.3	21.56
	8	15.32

<b>225A</b>	$i_n$	<b>ZA</b>
	5	369.11

### ZA..B - ZF..B - ZA..C - ZF..C

<b>80B</b>	$i_n$	<b>ZA</b>	<b>ZF</b>			
			IEC B5			
				<b>71</b>	<b>80</b>	<b>90</b>
	10	2.91		3.86	3.98	5.24
	12.5	2.74		3.69	3.81	5.07
	16	2.62		3.57	3.69	4.96
	20	1.19		2.14	2.27	3.53
	25	0.92		1.87	2.00	3.26
	31.5	0.89		1.84	1.97	3.23
	40	0.87		1.82	1.95	3.21
	50	0.86		1.80	1.93	3.19
	63	0.67		1.62	1.74	3.007

<b>80C</b>	$i_n$	<b>ZA</b>	<b>ZF</b>				
			IEC B5				
				<b>63</b>	<b>71</b>	<b>80</b>	<b>90</b>
	50	0.71		0.96	1.60	1.74	2.89
	63	0.67		0.93	1.57	1.70	2.85
	80	0.67		0.92	1.56	1.70	2.85
	100	0.30		0.55	1.19	1.32	2.48
	125	0.29		0.54	1.18	1.32	2.47
	160	0.29		0.54	1.18	1.31	2.47
	200	0.28		0.53	1.17	1.31	2.46
	250	0.28		0.53	1.17	1.30	2.46

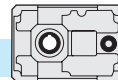





3.7 **Momenti d'inerzia** [Kg.cm<sup>2</sup>]  
(riferiti all'albero veloce in entrata)



3.7 **Moments of inertia** [Kg.cm<sup>2</sup>]  
(referred to input shaft)



3.7 **Trägheitsmoment** [Kg.cm<sup>2</sup>]  
(bez. Antriebswelle)

**ZA..B - ZF..B - ZA..C - ZF..C**

100B	$i_n$	ZA 	ZF 			
			IEC B5			
			71	80	90	110-112
10	9.50	11.51	11.83	11.76	11.79	
12.5	8.65	10.66	10.98	10.91	10.94	
16	8.25	10.26	10.58	10.51	10.54	
20	2.98	4.99	5.32	5.25	5.27	
25	2.97	4.98	5.31	5.24	5.27	
31.5	2.83	4.84	5.16	5.09	5.12	
40	2.76	4.77	5.09	5.02	5.05	
50	2.71	4.72	5.04	4.97	5.00	
63	1.88	3.89	4.22	4.15	4.18	

100C	$i_n$	ZA 	ZF 		
			IEC B5		
			71	80	90
50	2.93	3.78	3.92	5.09	
63	2.80	3.66	3.80	4.97	
80	2.78	3.64	3.77	4.95	
100	1.22	2.07	2.21	3.38	
125	1.19	2.04	2.18	3.35	
160	1.18	2.04	2.17	3.35	
200	1.15	2.01	2.14	3.32	
250	1.15	2.00	2.14	3.32	

125B	$i_n$	ZA 	ZF 			
			IEC B5			
			80	90	110-112	132
10	27.97	32.64	32.54	32.72	47.58	
12.5	25.19	29.86	29.76	29.94	44.80	
16	24.15	28.83	28.73	28.91	43.77	
20	11.10	15.77	15.67	15.85	30.71	
25	8.67	13.35	13.25	13.43	28.29	
31.5	8.18	12.86	12.76	12.94	27.80	
40	8.00	12.68	12.58	12.76	27.62	
50	7.86	12.53	12.44	12.61	27.47	
63	5.45	10.13	10.03	10.21	25.07	

125C	$i_n$	ZA 	ZF 			
			IEC B5			
			71	80	90	110-112
50	9.06	11.32	11.39	11.32	13.63	
63	8.69	10.96	11.03	10.96	13.27	
80	8.62	10.88	10.95	10.88	13.20	
100	3.92	6.18	6.26	6.18	8.50	
125	3.83	6.09	6.16	6.09	8.41	
160	3.81	6.07	6.15	6.07	8.39	
200	3.72	5.99	6.06	5.99	8.30	
250	3.72	5.98	6.05	5.98	8.30	

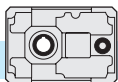





3.7 **Momenti d'inerzia** [Kg.cm<sup>2</sup>]  
(riferiti all'albero veloce in entrata)



3.7 **Moments of inertia** [Kg.cm<sup>2</sup>]  
(referred to input shaft)



3.7 **Trägheitsmoment** [Kg.cm<sup>2</sup>]  
(bez. Antriebswelle)

### ZA..B - ZF..B - ZA..C - ZF..C

160B	$i_n$	ZA 	ZF 				
			IEC B5				
			90	110-112	132	160	180
10	86.86	105.43	106.47	107.84	110.02	159.14	
12.5	77.37	95.94	96.98	98.35	100.53	149.65	
16	74.72	93.29	94.33	95.70	97.88	147.00	
20	33.94	52.52	53.56	54.92	57.10	106.22	
25	26.65	45.23	46.27	47.63	49.81	98.93	
31.5	24.99	43.57	44.61	45.97	48.16	97.27	
40	24.53	43.11	44.15	45.51	47.69	96.81	
50	24.00	42.58	43.62	44.98	47.16	96.28	
63	16.56	35.14	36.18	37.54	39.72	88.84	

160C	$i_n$	ZA 	ZF 			
			IEC B5			
			80	90	110-112	132
50	27.22	31.55	31.80	31.97	46.83	
63	26.09	30.43	30.67	30.85	45.71	
80	25.84	30.17	30.41	30.59	45.45	
100	11.47	15.80	16.05	16.22	31.08	
125	11.19	15.52	15.76	15.94	30.80	
160	11.12	15.46	15.70	15.88	30.74	
200	10.85	15.19	15.43	15.61	30.47	
250	10.84	15.18	15.42	15.59	30.45	

180B	$i_n$	ZA 	ZF 				
			IEC B5				
			90	110-112	132	160	180
8	122.78	141.36	142.40	143.76	145.94	195.06	
10	108.97	127.55	128.59	129.95	132.13	181.25	
12.5	98.50	117.08	118.12	119.48	121.67	170.78	
16	44.65	63.22	64.26	65.63	67.81	116.93	
20	41.18	59.76	60.80	62.17	64.35	113.46	
25	38.56	57.13	58.17	59.54	61.72	110.84	
31.5	37.10	55.67	56.71	58.08	60.26	109.38	
40	35.98	54.55	55.59	56.96	59.14	108.26	

180C	$i_n$	ZA 	ZF 			
			IEC B5			
			80	90	110-112	132
50	28.35	32.68	32.93	33.10	47.96	
63	27.03	31.36	31.61	31.78	46.64	
80	26.75	31.08	31.33	31.50	46.36	
100	26.59	30.93	31.17	31.34	46.20	
125	12.10	16.43	16.67	16.85	31.71	
160	11.79	16.13	16.37	16.55	31.41	
200	11.48	15.82	16.06	16.24	31.10	
250	11.46	15.80	16.04	16.21	31.07	

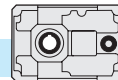





3.7 **Momenti d'inerzia** [Kg.cm<sup>2</sup>]  
(riferiti all'albero veloce in entrata)

3.7 **Moments of inertia** [Kg.cm<sup>2</sup>]  
(referred to input shaft)

3.7 **Trägheitsmoment** [Kg.cm<sup>2</sup>]  
(bez. Antriebswelle)

### ZA..B - ZF..B - ZA..C - ZF..C

200B	$i_n$	ZA 	ZF 			
			IEC B5			
			132	160	180	200
8	301.72	363.02	371.00	369.00	365.53	
10	285.61	346.91	354.88	352.89	349.41	
12.5	270.18	331.48	339.45	337.46	333.98	
16	114.96	176.26	184.24	182.24	178.77	
20	110.92	172.22	180.19	178.20	174.72	
25	107.05	168.35	176.32	174.33	170.85	
31.5	103.91	165.21	173.19	171.19	167.72	

200C	$i_n$	ZA 	ZF 			
			IEC B5			
			110-112	132	160	180
40	85.01	104.63	105.99	108.17	157.29	
50	84.39	104.00	105.37	107.55	156.67	
63	83.79	103.41	104.77	106.96	156.07	
80	83.31	102.93	104.29	106.47	155.59	
100	34.63	54.25	55.61	57.80	106.91	
125	34.48	54.10	55.46	57.65	106.76	
160	34.36	53.98	55.34	57.52	106.64	

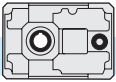

3.8 Dimensioni

3.8 Dimensions

3.8 Abmessungen

	ZA...A						ZA...B - ZF...B - ZA...C - ZF...C																			
	71		90		112		140		180		225		80		100		125		160		180		200			
<b>A</b>	142		180		224		280		360		450		160		200		250		320		360		400			
<b>a</b>	102		134		166		209		272.5		344		82		102		127		162.5		185		204			
<b>a1</b>	—																									
<b>B</b>	112		127		150		175		215		290		127		150		175		215		255		290			
<b>b</b>	90		104		125		145		180		240		104		125		145		180		210		240			
<b>C2</b>	115		130		155		180		220		300		130		155		180		220		260		300			
<b>D2 H7</b>	<b>24</b>	<b>28</b>	<b>32</b>	<b>30</b>	<b>35</b>	<b>42</b>	<b>40</b>	<b>45</b>	<b>55</b>	<b>50</b>	<b>70</b>	<b>60</b>	<b>100</b>	<b>32</b>	<b>30</b>	<b>35</b>	<b>42</b>	<b>40</b>	<b>45</b>	<b>55</b>	<b>50</b>	<b>70</b>	<b>60</b>	<b>90</b>	<b>80</b>	<b>100</b>
<b>E</b>	206		262		326		407		522.5		654		306		384		479		609.5		652		766.5			
<b>e</b>	38		52		64		82		110		140		42		52		67		90		100		115			
<b>F</b>	9		11		13		15		17		21		11		13		15		17		19		21			
<b>f</b>	M8x13		M10x16		M12x19		M14x21		M16x25		M18x30		M10x16		M12x19		M14x22		M16x25		M18x35		M18x30			
<b>G</b>	122		155		194		244		320		400		135		170		214		280		310		350			
<b>g</b>	61		77.5		97		122		160		200		67.5		85		107		140		155		175			
<b>H</b>	71		90		112		140		180		225		80		100		125		160		180		200			
<b>H1</b>	—																									
<b>H2</b>	—																									
<b>i</b>	125		159.5		199		249		322.5		404		213.5		269		336		429.5		447		541.5			
<b>O</b>	64		82		102		127		162.5		204		146		184		229		289.5		312		366.5			
<b>O1</b>	—																									
<b>Z</b>	9		11		13		15		17		25		11		13		15		17		22		25			

	ZA...A						ZA...B						ZA...C											
	71		90		112		140		180		225		80		100		125		160		180		200	
<b>D1 h6</b>	19		24		28		38		48		60		19		24		28		38		48		14	
<b>S</b>	105		127.5		150		190		230		260		105		127.5		150		190		230		95	
<b>U</b>	65		77.5		90		110		150		150		65		77.5		90		110		130		150	
<b>V</b>	40		50		60		80		80		110		40		50		60		80		80		30	
<b>kg</b>	11.5		18		30.5		52		104		210		18		34		62		114		165		250	

	ZF...B																		
	80			100			125			160			180			200			
<b>IEC</b>	71	80/90	71	80/90	100/112	80/90	100/112	132	90	100/112	132	160/180	80/90	100/112	132	160/180	132	160/180	200
<b>Y</b>	160	200	160	200	250	200	250	300	200	250	300	350	200	250	300	350	300	350	400
<b>R</b>	151	172	162	182	192	205	215	236	245	255	276	306	266	276	297	327	316	346	348
<b>kg</b>	21			39			72			131			185			280			

	ZF...C																		
	80			100			125			160			180			200			
<b>IEC</b>	63	71	80/90	71	80/90	71	80/90	100/112	80/90	100/112	132	80/90	100/112	132	100/112	132	160/180	132	160/180
<b>Y</b>	140	160	200	160	200	160	200	250	200	250	300	200	250	300	250	300	250	300	350
<b>R</b>	132	139	160	152	173	176	197	207	230	240	261	245	255	276	295	316	346	348	
<b>kg</b>	23			43			78			142			200			305			

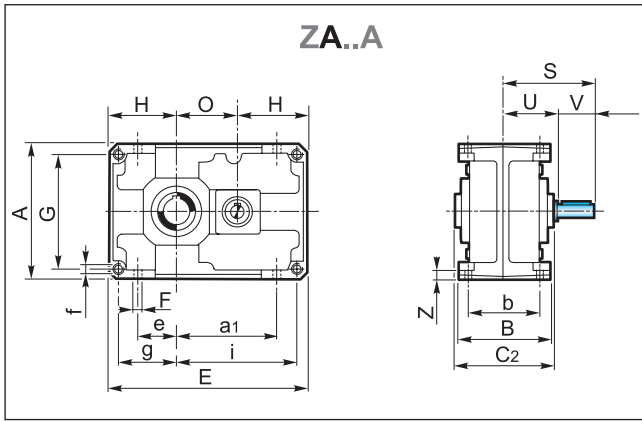
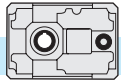

Albero entrata  
Input shaft  
Antriebswelle

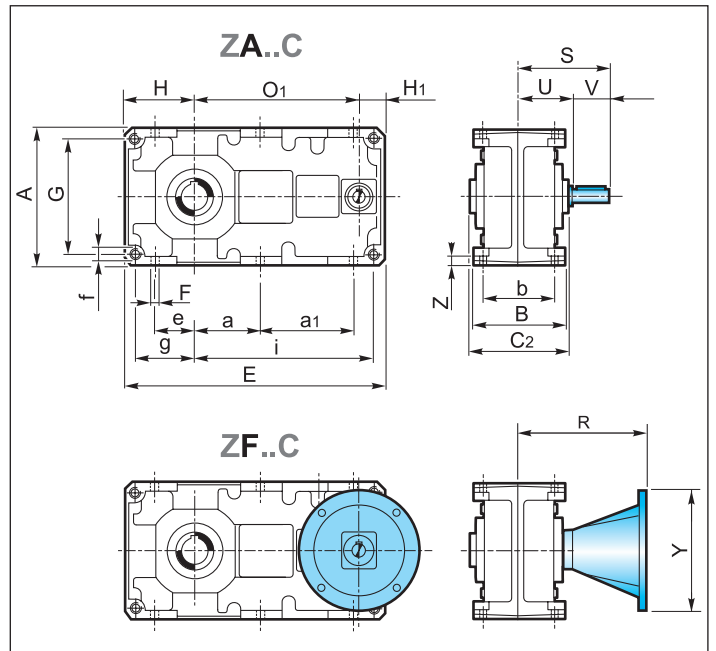
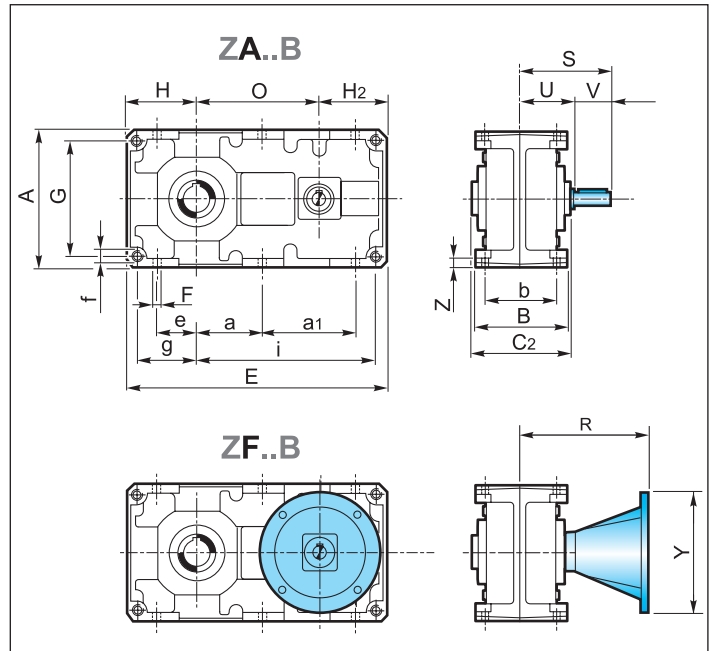
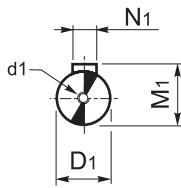

ZA...A		71	90	112	140	180	225
D1 h6		19	24	28	38	48	60
d1		M8	M8	M8	M10	M12	M16
M1		21.5	27	31	41	51.5	64
N1		6	8	8	10	14	18
ZA...B		80	100	125	160	180	200
D1 h6		19	24	28	38	38	48
d1		M8	M8	M8	M10	M10	M12
M1		21.5	27	31	41	41	51.5
N1		6	8	8	10	10	14
ZA...C		80	100	125	160	180	200
D1 h6		14	19	24	28	28	38
d1		M6	M8	M8	M8	M8	M10
M1		16	21.5	27	31	31	41
N1		5	6	8	8	8	10

ZA...A		71	90	112	140	180	225							
C2		115	130	155	180	220	300							
D2 H7	24	28	32	30	35	42	40	45	55	50	70	60	100	90
M2	27.3	31.3	35.3	33.3	38.3	45.3	43.3	48.8	59.3	53.8	74.9	64.4	106.4	95.4
N2	8	8	10	8	10	12	12	14	16	14	20	18	28	25
Z2	—	8.7	8.7	8.4	11	11	11	11.9	15.4	15.9	20	-	-	-
ZA...B - ZF...B - ZA...C - ZF...C		80	100	125	160	180	200							
C2		130	155	180	220	260	300							
D2 H7	32	30	35	42	40	45	55	50	70	60	90	80	100	90
M2	35.3	33.3	38.3	45.3	43.3	48.8	59.3	53.8	74.9	64.4	95.4	85.4	106.4	95.4
N2	10	8	10	12	12	14	16	14	20	18	25	22	28	25
Z2	8.7	8.7	8.4	11	11	11	11.9	15.4	15.9	18.9	18.9	20	-	-

Albero uscita cavo  
Hollow output shaft  
Abtriebshohlwelle

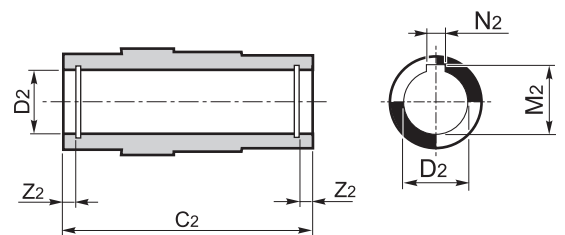

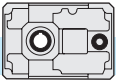

### 3.9 Seconda entrata

A richiesta è possibile fornire il riduttore con entrata supplementare.

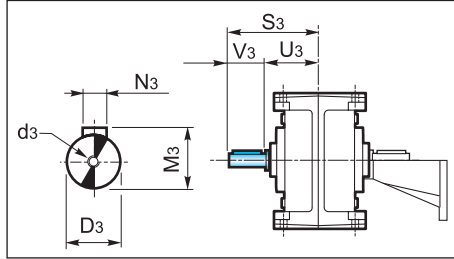

### 3.9 Second input

On request it is possible to supply the gearbox with an additional input.

### 3.9 Zweiter Antrieb

Auf Wunsch ist das Getriebe mit Zusatzantrieb lieferbar.

	ZA...											
	80B	100B	125B	160B	180B	200B	80C	100C	125C	160C	180C	200C
D3 <sub>g6</sub>	14	19	24	28	28	38	14	14	19	24	24	28
d3	M6	M8	M8	M8	M8	M10	M6	M6	M8	M8	M8	M8
N3	5	6	8	8	8	10	5	5	6	8	8	8
M3	16.3	21.8	27.3	31.3	31.3	41.3	16.3	16.3	21.8	27.3	27.3	31.3
S3	95	117.5	140	170	190	230	95	107.5	130	160	180	210
U3	65	77.5	90	110	130	150	65	77.5	90	110	130	150
V3	30	40	50	60	60	80	30	30	40	50	50	60

### 3.10 Accessori

#### Albero lento

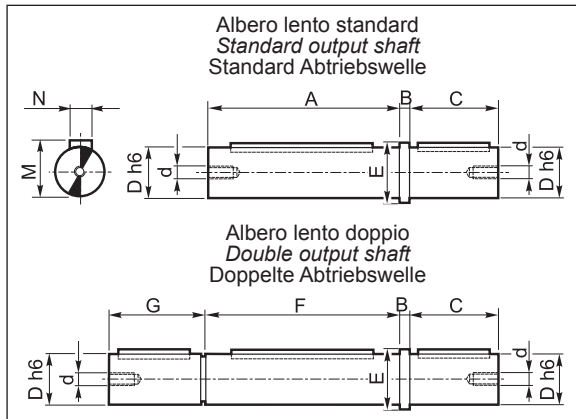

### 3.10 Accessories

#### Output shaft

### 3.10 Zubehör

#### Abtriebswelle

	Z...						
	71A	90A 80B 80C	112A 100B 100C	140A 125B 125C	180A 160B 160C	180B 180C	225A 200B 200C
A	114	129	129	154	154	179	219
B	5	6	6	8	8	10	12
C	50	60	60	80	80	100	125
D <sub>h6</sub>	24	32	35	42	45	55	70
d	M8	M8	M8	M10	M10	M10	M12
E	30	40	43	50	53	65	80
F	115	130	—	155	—	180	220
G	49	59	—	79	—	99	124
M	27	35	38	45	48.5	59	74.5
N	8	10	10	12	14	16	20

Materiale albero lento: C45 - Output shaft material: C45 - Material der Abtriebswelle: C45

### Kit fissaggio e smontaggio riduttori con albero lento cavo

### Kit for the mounting and dismounting of the gearboxes with hollow output shaft

### Kit für Montage und Ausbau der Getriebe mit Abtriebshohlwelle

	Z												
	90A 80B 80C			112A 100B 100C			140A 125B 125C		180A 160B 160C		180B 180C		225A 200B 200C
C2	130			155			180		220		260		300
D2	32	30	35	42	40	45	55	50	70	60	90	80	100
H	8	7	6.5	10	8		9		12		16	15.5	17
d1	—			—			M10		M12		M16		M18
d2	—			—			M8		M10		M12		M16
d3	M8			M8			—		—		—		—
d4	M12			M12			—		—		—		—
Z2	8.7		8.4	10.7			11.9		15.4	15.9	18.9	19.4	16.9
Lmax	111	112		131	133		156		189		221		262
Lmin	106	107		126	128		149		182		211		252

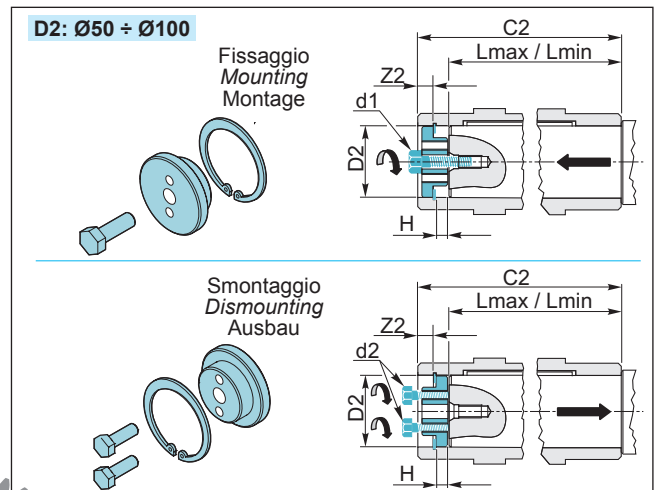
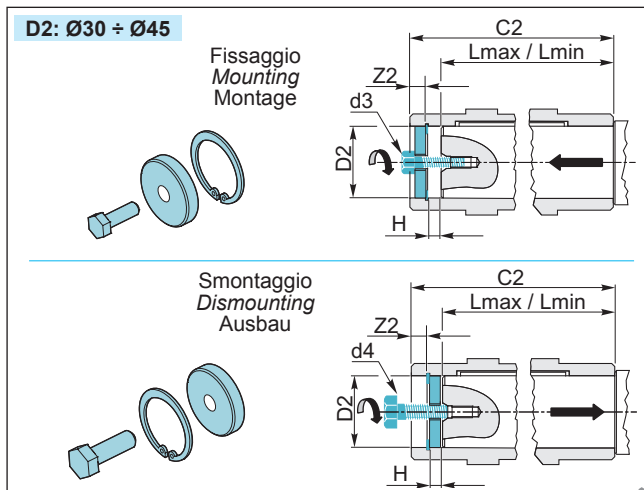



### Albero lento cavo con calettatore

### Hollow output shaft with shrink disc

### Abtriebshohlwelle mit Schrumpfscheibe

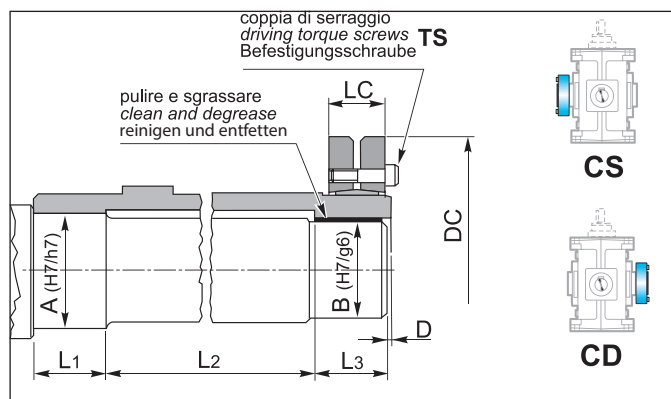

	Z						
	71A	90A 80B 80C	112A 100B 100C	140A 125B 125C	180A 160B 160C	180B 180C	225A 200B 200C
A	27	37	47	57	72	92	102
B	25	35	45	55	70	90	100
D	2	2	2	2	2	3	3
DC	60	80	100	115	155	188	215
LC	22	26	31	31	39	50	54
L <sub>1</sub>	36	39	45	50	60	70	80
L <sub>2</sub>	68	82	100	115	143	175	200
L <sub>3</sub>	36	39	45	50	60	70	80
TS (Nm)	4	12	12	12	30	59	59

### Kit protezione albero cavo

### Hollow shaft protection kit

### Schutzvorrichtung für die Hohlwelle

A richiesta è possibile predisporre il riduttore con un kit di protezione dell'albero cavo. Tale protezione, essendo dotata di un'opportuna guarnizione, impedisce ad eventuali fluidi, presenti nell'ambiente di lavoro, di venire a contatto con l'albero cavo del riduttore oltre ad impedire il contatto con corpi estranei. Le dimensioni di ingombro sono riportate nella tabella seguente.

On request we can supply a hollow shaft protection kit. The kit features a gasket which prevents any contact between hollow shaft and foreign bodies or fluids existing in the working environment. Over-all dimensions are reported in the following table.

Auf Wunsch ist eine Schutzvorrichtung für die Hohlwelle lieferbar. Die Schutzvorrichtung weist eine Dichtung auf, die zur Vermeidung von irgendwelchem Kontakt zwischen Hohlwelle und Fremdkörper oder Flüssigkeiten der Arbeitsumgebung dient. In der folgenden Tabelle wird den Raumbedarf angegeben.

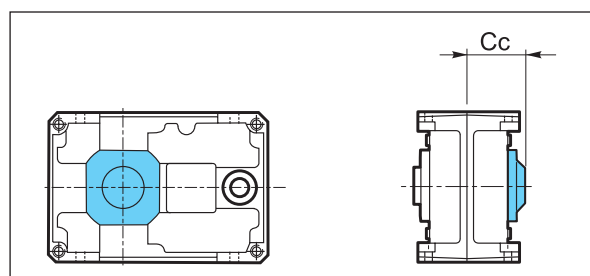

	Z						
	71A	90A 80B 80C	112A 100B 100C	140A 125B 125C	180A 160B 160C	180B 180C	225A 200B 200C
Cc	79.5	87	105	120.5	141.5	167.5	191.5

### Flangia uscita

### Output flange

### Abtriebsflansch

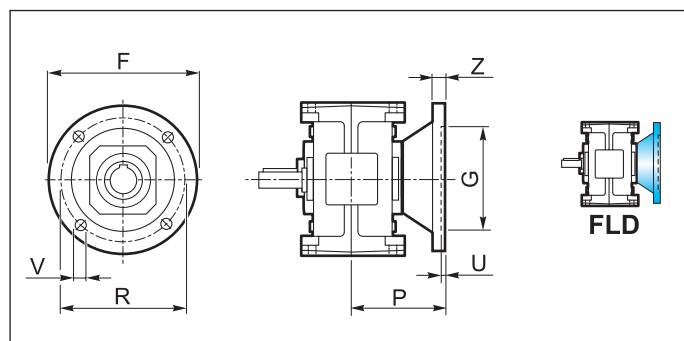

	Z...					
	71A	90A 80B 80C	112A 100B 100C	140A 125B 125C	180A 160B 160C	180B 180C
F	160	200	250	300	350	400
G <sub>F7</sub>	110	130	180	230	250	300
R	130	165	215	265	300	350
P	87	100	125	150	180	215
U	4	4.5	5	5	6	6
V	12	12	14	16	18	20
Z	10	12	16	20	25	30
kg	2	3.2	5	8	12.5	24

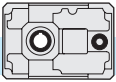

### Braccio di reazione

### Torque arm

### Drehmomentstütze

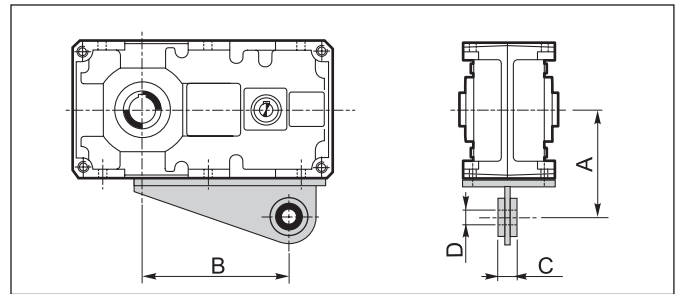
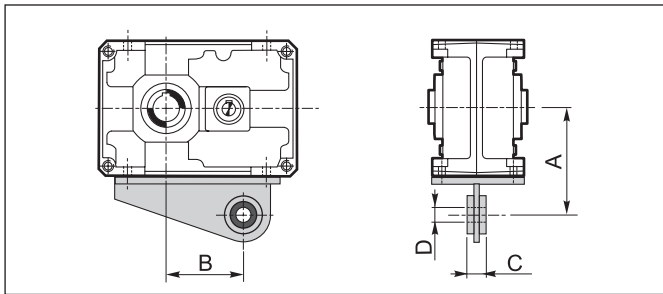

	Z					
	71A	90A	112A	140A	180A	225A
A	123	140	172	205	260	325
B	84	116	144	189	247.5	319
C	25	25	30	30	35	45
D	20	20	25	25	35	40

	Z					
	80B 80C	100B 100C	125B 125C	160B 160C	180B 180C	200B 200C
A	130	160	190	240	280	300
B	170	214	276	354.5	367	456.5
C	25	30	30	35	45	45
D	20	25	25	35	40	40

### Dispositivo antiritorno

### Backstop device

### Rücklaufsperre

Il riduttore ad assi paralleli presenta valori di rendimento statico (e dinamico) molto elevati: per questo motivo non è garantita spontaneamente l'irreversibilità statica. L'irreversibilità statica si realizza quando, a riduttore fermo, l'applicazione di un carico all'albero lento non pone in rotazione l'asse entrata. Pertanto, per garantire l'irreversibilità del moto, a riduttore fermo, occorre predisporre il riduttore stesso con un opportuno dispositivo antiritorno, fornibile a richiesta solo nel caso di riduttore a 2 o 3 stadi di riduzione (Z...B e Z...C). Tale dispositivo permette la rotazione dell'albero lento solo nel senso desiderato, da specificare all'atto dell'ordine.

*Parallel shaft gearboxes feature quite high values of static (and dynamic) efficiency: for this reason spontaneous static irreversibility is not guaranteed. Static irreversibility, with motionless gearbox, occurs when the application of a load on the output shaft does not cause rotation of the input axis. In order to guarantee motion irreversibility, with motionless gearbox, it is necessary to fit a backstop device, which is available on request only for gearbox with 2 or 3 reduction stages (Z...B and Z...C). The backstop device enables rotation of the output shaft only in the required direction, which is to be specified when ordering.*

Parallelengetriebe haben sehr hohen statischen (und dynamischen) Wirkungsgrade: deshalb wird keine spontane statische Irreversibilität garantiert. Statische Irreversibilität bei stillstehenden Getriebe hat man, wenn die Applikation einer Last auf die Abtriebswelle keine Drehung der Antriebswelle verursacht. Um Irreversibilität der Bewegung bei stillstehendem Getriebe zu sichern, soll eine Rücklaufsperre montiert werden. Die Rücklaufsperre wird auf Wunsch nur für Getriebe mit entweder 2 oder 3 Untersetzungsstufen (Z.B und Z...C) geliefert. Die Rücklaufsperre ermöglicht, dass die Abtriebswelle nur in der gewünschten Richtung dreht (gewünschte Richtung beim Bestellen angeben).

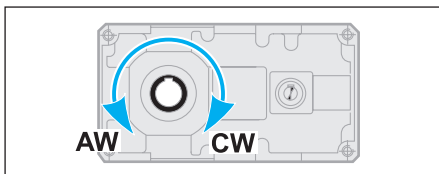

- CW** Rotazione oraria  
Clockwise rotation  
Im Uhrzeigersinn
- AW** Rotazione antioraria  
Anti-clockwise rotation  
Gegen den Uhrzeigersinn

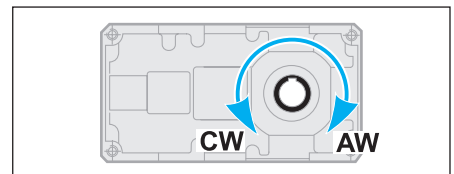

Nel caso in cui sia presente il dispositivo antiritorno è necessario l'utilizzo di olio lubrificante sintetico, classe di viscosità ISO 150.

*The utilization of synthetic oil, viscosity class ISO 150, is necessary for the gearboxes equipped with back stop device.*

Getriebe mit einer Rücklaufsperre müssen mit synthetischem Öl (Viskosität ISO150) betrieben werden.

Nella tabella seguente (tab 3) sono indicati i valori dei momenti torcenti nominali massimi ( $T_{2Mmax}$ ), riferiti all'albero uscita, garantiti dal dispositivo di antiritorno, per ogni rapporto di riduzione e per ogni grandezza di riduttore. Se, in corrispondenza dell'albero lento, viene applicata una coppia maggiore di quella indicata, l'irreversibilità del moto non è più garantita. Questi valori di coppia non sono da confondere con quelli riportati nella tabella riguardante i dati tecnici dei riduttori. Infatti, si noti come in tabella siano stati messi in evidenza i valori di coppia garantiti (in uscita) dal dispositivo antiretro che risultano essere minori dei massimi valori di coppia motrice trasmissibili, con fattore di servizio  $F_s = 1$ , dal riduttore.

*The following table (tab.3) shows the max. rated torques ( $T_{2Mmax}$ ) at gearbox output guaranteed by the backstop device, for each ratio and each gearbox size. If a higher torque is applied at gearbox output, motion irreversibility is no longer guaranteed.*

In der folgenden Tabelle (Tab. 3) werden die max. Nenn Drehmomente am Abtrieb angegeben ( $T_{2Mmax}$ ), die die Rücklaufsperre je nach Untersetzungsverhältnis und Getriebegröße garantiert. Falls am Abtrieb ein höheres Drehmoment eingesetzt wird, dann ist die Irreversibilität der Bewegung nicht mehr garantiert. Diese Drehmomente sind nicht mit den Werten zu verwechseln, die in der Tabelle der technischen Daten der Getriebe angegeben werden.

Vedere paragrafo 1.5 per la verifica del dispositivo antiritorno.

*To check the back stop device pls see paragraph 1.5.*

Die von der Rücklaufsperre (am Abtrieb) garantierten Drehmomente sind niedriger als die von Getriebe übersetzbaren max. Drehmomente, unter Berücksichtigung eines Betriebsfaktors  $F_s = 1$ .

Für die Überprüfung der Rücklaufsperre siehe Abschnitt 1.5.

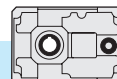

**Coppia massima garantita in uscita dal dispositivo antiritorno**  
**Max. output torque guaranteed by the backstop device**  
**Von der Rücklauf Sperre garantierten max. Abtriebsdrehmomente**

Tab. 3

	$T_{2M}$ max [Nm]									
	8	10	12.5	16	20	25	31.5	40	50	63
<b>Z80B</b>	—	544	692	830	1086	1301	1656	1985	2566	3319
<b>Z100B</b>	—	850	1082	1297	1697	2033	2588	3101	4010	5186
<b>Z125B</b>	—	1870	2380	2853	3733	4473	5693	6822	8822	11409
<b>Z160B</b>	—	3944	5019	6017	7873	9435	12006	14388	18606	24062
<b>Z180B</b>	6093	7808	9433	11705	15594	18828	23357	31608	—	—
<b>Z200B</b>	6266	7522	9245	12509	15022	18452	22597	—	—	—

	$T_{2M}$ max [Nm]									
	40	50	63	80	100	125	160	200	250	
<b>Z80C</b>	—	1400	1678	2135	2814	3371	4291	5550	6650	
<b>Z100C</b>	—	2770	3318	4223	5529	6625	8432	10905	13066	
<b>Z125C</b>	—	4328	5185	6599	8639	10352	13175	17038	20416	
<b>Z160C</b>	—	9521	11407	14518	19006	22774	28985	37484	44915	
<b>Z180C</b>	—	9689	11702	14518	18134	22497	28985	36201	44915	
<b>Z200C</b>	16399	19693	24186	29615	39316	48283	59125	—	—	

Valori di coppia garantiti inferiori alla  $T_{2M}$     Torque values guaranteed lower than  $T_{2M}$  value    Zuverlässige Drehmomente unter  $T_{2M}$  Wert

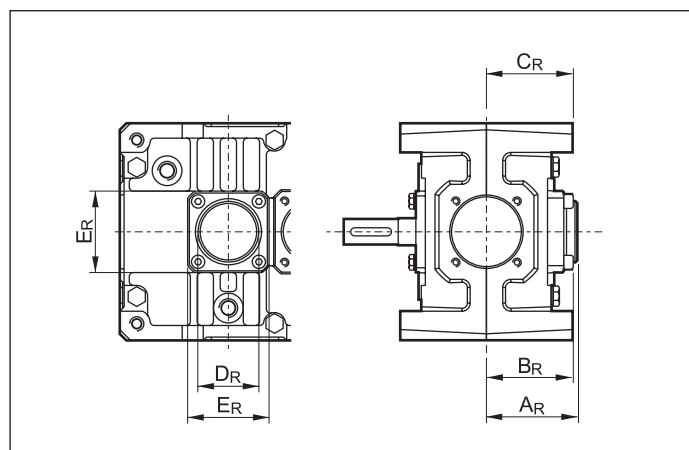

	$A_R$	$B_R$	$C_R$	$D_R$	$E_R$
<b>Z 80C</b>	59	57	63.5	52	60
<b>Z 80B</b>	67	56	63.5	45	60
<b>Z 100C</b>	72	61	75	45	60
<b>Z 100B</b>	71.5	63.5	75	55	80
<b>Z 125C</b>	86.5	78.5	87.5	55	80
<b>Z 125B</b>	86.5	81	87.5	60	90
<b>Z 160C</b>	96.5	91	107.5	60	90
<b>Z 180B</b>	127	114	127.5	80	100
<b>Z 180C</b>	108	108	127.5	60	90
<b>Z 160B</b>	106.5	95	107.5	70	100
<b>Z 200C</b>	126.5	115	145	70	100
<b>Z 200B</b>	125	116	145	90	130

Dimensioni riferite alla versione con antiretro    Dimensions of the version with backstop device    Abmessungen der Version mit Rücklauf Sperre

**3.11 Giochi angolari**

Bloccando l'albero di entrata, il gioco viene misurato sull'albero uscita ruotandolo nelle due direzioni ad applicando la coppia strettamente necessaria a creare il contatto tra i denti degli ingranaggi, al massimo pari al 2% della coppia massima garantita dal riduttore. Nella tabella seguente sono riportati i valori indicativi del gioco angolare (in minuti di angolo).

**3.11 Angular backlash**

After having blocked the input shaft, the angular backlash can be measured on the output shaft by rotating it in both directions and applying the torque which is strictly necessary to create a contact between the teeth of the gears. The applied torque should be at most 2% of the max. torque guaranteed by the gearbox. The following table reports the approximate values of the angular backlash (in minutes of arc).

**3.11 Winkelspiel**

Nachdem die Antriebswelle blockiert worden ist, kann das Winkelspiel an der Abtriebswelle gemessen werden. Dabei soll die Abtriebswelle in beiden Richtungen gedreht und ein Drehmoment ausgeübt werden, das zur Entstehen eines Kontaktes zwischen den Zähnen genügt. Das ausgeübte Drehmoment soll höchstens 2% des max. vom Getriebe garantierten Drehmoment sein. Die folgende Tabelle zeigt die Näherungswerte des Winkelspiels (in Bogenminuten).

<b>Gioco angolare / Backlash / Winkelspiel (1')</b>					
<b>Z..A</b>	10-16	<b>Z..B</b>	16-20	<b>Z..C</b>	20-25

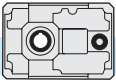

### 3.12 Lubrificazione

I riduttori ad assi paralleli sono forniti predisposti per lubrificazione a olio e muniti dei tappi di carico, livello e scarico olio. Si raccomanda di precisare sempre la posizione di montaggio desiderata in fase di ordine.

#### POMPA OLIO

Una pompa per lubrificazione forzata dei cuscinetti superiori è fornita a richiesta sulle grandezze 125, 140, 160, 180, 200 e 225 nella posizione di montaggio VA.

#### Posizione di montaggio e quantità di lubrificante (litri)

Nella posizione di montaggio V1-V3 è previsto un tappo di sfiato con asta di livello.

I quantitativi di olio riportati nelle varie tabelle sono indicativi e riferiti alle posizioni di lavoro indicate e considerando le condizioni di funzionamento a temperatura ambiente e velocità in ingresso di 1400 min<sup>-1</sup>. Per condizioni di lavoro diverse da quelle sopra riportate contattare il servizio tecnico.

### 3.12 Lubrication

Parallel shaft gearboxes require oil lubrication and are equipped with filler, level and drain plugs. The mounting position should always be specified when ordering the gearbox.

#### OIL PUMP.

A pump for forced lubrication of the upper bearings is supplied on request for sizes 125, 140, 160, 180, 200 and 225 in the VA mounting position.

#### Mounting positions and lubricant quantity (liters)

In mounting position V1-V3 the breather is fitted with dipstick.

The oil quantities stated in the tables are approximate values and refer to the indicated working positions, considering operating conditions at ambient temperature and an input speed of 1400 min<sup>-1</sup>. Should the operating conditions be different, please contact the technical service.

### 3.12 Schmierung

Parallelengetriebe sind für Ölschmierung mit Einfüll-, Ölstand- und Ablassstopfen versehen.

Bei der Bestellung ist immer die gewünschte Montageposition anzugeben.

#### ÖLPUMPE.

Eine Pumpe für die Zwangsschmierung der oberen Lager wird auf Wunsch bei den Größen 125, 140, 160, 180, 200 und 225 in der Montageposition VA geliefert.

#### Montageposition und Ölmenge (liter)

Für die V1-V3 Version ist eine Entlüftungsschraube mit Ölstandanzeiger vorausgesehen.

Die in der Tabellen angegebenen Daten sind Richtwerte. Die Ölmengen beziehen sich auf die angegebene Betriebsposition. Dabei werden Betrieb bei Umgebungstemperatur und Antriebsdrehzahl von 1400 min<sup>-1</sup> berücksichtigt. Falls die Betriebsbedingungen anders sind, dann ist das technische Büro zu befragen.

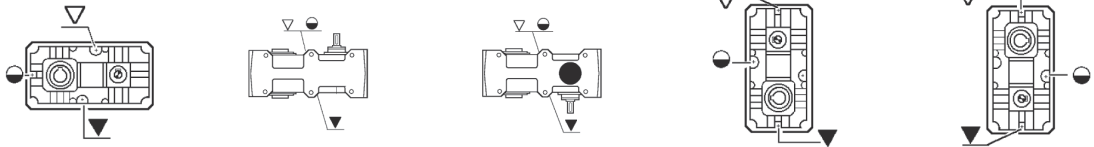

Z	B3	V1	V3	VA	VB
71A	0.6	0.75	0.75	0.6	0.7
80B - 80C	1.1	1.5	1.5	1.5	1.5
90A	1.2	1.5	1.5	1.2	1.3
100B - 100C	2.0	2.6	2.6	2.8	2.8
112A	2.0	2.6	2.6	2.0	2.2
125B - 125C	3.8	4.8	4.8	5.0	5.0
140A	3.7	4.8	4.8	3.7	4.0
160B - 160C	7.0	9.2	9.2	10	10.0
180A	7.1	9.2	9.2	7.1	7.8
180B - 180C	9.5	14.0	13.0	15.5	16.0
200B -200C	13.5	19.0	19.0	19.5	19.5
225A	13.5	17.5	17.5	13.5	14.8

#### Posizione morsettiera

#### Terminal board position

#### Lage des Klemmenkastens

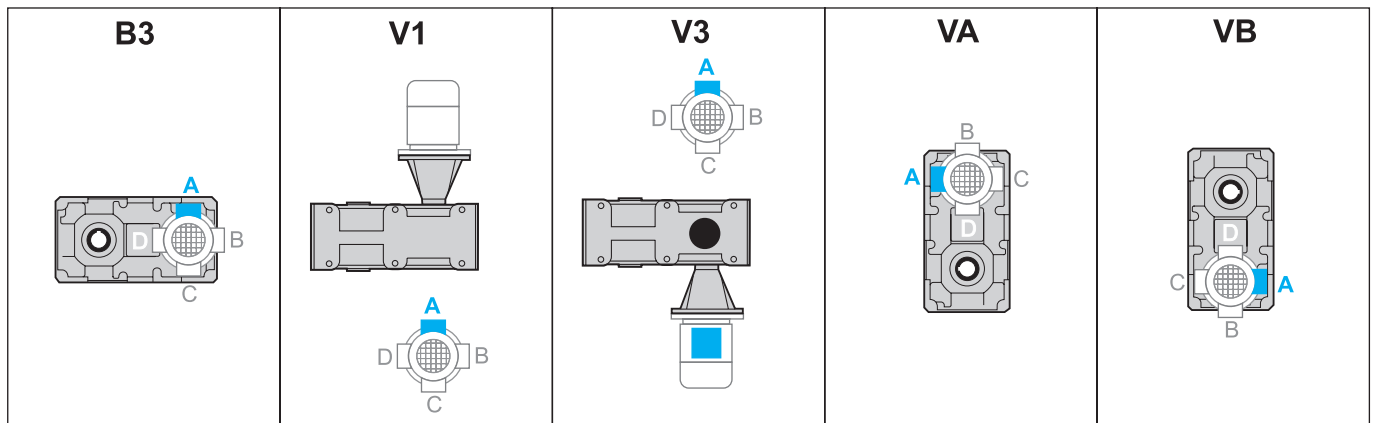

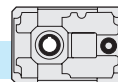

### 3.13 Carichi radiali e assiali (N)

Le trasmissioni effettuate tramite pignoni per catena, ruote dentate o pulegge generano delle forze radiali ( $F_R$ ) sugli alberi dei riduttori. L'entità di tali forze può essere calcolata con la formula:

### 3.13 Radial and axial loads (N)

Transmissions implemented by means of chain pinions, wheels or pulleys generate radial forces ( $F_R$ ) on the gear unit shafts. The entity of these forces may be calculated using the following formula:

### 3.13 Radial- und Axialbelastungen (N)

Antriebe mit Kettenritzel, Zahnrädern oder Riemenscheiben erzeugen radiale Kräfte ( $F_R$ ) an den Wellen der Untersetzungsgetriebe. Das Ausmaß dieser Kräfte kann nach folgender Formel berechnet werden:

$$F_R = \frac{K_R \cdot T}{d} \text{ [N]}$$

dove:

T = Momento torcente [Nm]  
d = Diametro pignone o puleggia [mm]

$K_R$  = 2000 per pignone per catena  
= 2500 per ruote dentate  
= 3000 per puleggia con cinghie a V

where:

T = torque [Nm]  
d = pinion or pulley diameter [mm]

$K_R$  = 2000 for chain pinion  
= 2500 for wheel  
= 3000 for V-belt pulley

dabei ist:

T = Drehmoment [Nm]  
d = Kettenritzel- bzw. Riemenscheiben  
durchmesser [mm]

$K_R$  = 2000 bei Kettenritzel  
= 2500 bei Zahnrad  
= 3000 bei Riemenscheibe mit  
Keilriemen

I valori dei carichi radiali e assiali generati dall'applicazione debbono essere sempre minori o uguali a quelli ammissibili indicati nelle tabelle.

The values of the radial and axial loads generated by the application must always be lower than or equal to the admissible values reported in the tables.

Die Werte der Radial- und Axialbelastungen, die durch die Anwendung hervorgerufen werden, dürfen nicht über den in den Tabellen angegebenen zulässigen Werten liegen.

$$F_R \geq Fr_{1-2}$$

Se il carico radiale sull'albero non è applicato a metà della sporgenza dell'albero, il valore del carico ammissibile deve essere valutato utilizzando la formula che si riferisce ad  $Fr_{1-2}$ , in cui i valori di a, b e  $Fr_{1-2}$  sono riportati nelle tabelle relative ai carichi radiali.

Nel caso di alberi bisporgenti il valore del carico applicabile a ciascuna estremità è uguale ai 2/3 del valore di tabella, purché i carichi applicati siano uguali di intensità e direzione ed agiscano nello stesso senso. Diversamente contattare il servizio tecnico.

Should the radial load affect the shaft not at the half-way point of its projection but at a different point, the value of the admissible load has to be calculated using the  $Fr_{1-2}$  formula: a, b and  $Fr_{1-2}$  values are reported in the radial load tables.

With regard to double-projecting shafts, the load applicable at each end is 2/3 of the value given in the table, on condition that the applied loads feature same intensity and direction and that they act in the same direction.

Otherwise please contact the technical department.

Falls die Radialbelastungen nicht in dem Mittelpunkt der herausragenden Welle sondern in einem anderen Punkt wirken, soll die zulässige Belastung mit der Formel bezüglich  $Fr_{1-2}$  kalkuliert werden: a, b und  $Fr_{1-2}$  Werte sind aus der Tabelle der Radialbelastungen zu entnehmen.

Bei doppelseitigen Wellen ist die Belastung, die an jedem Ende anwendbar ist, 2/3 des in der Tabelle angegebenen Wertes unter der Bedingung, daß sie in dieselbe Richtung wirken. Andernfalls muß mit dem technischen Büro Rücksprache gehalten werden.

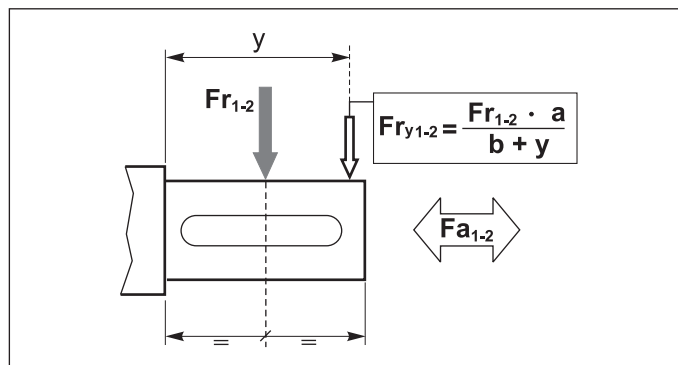

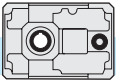

Tab. 6

	Z 71A		Z 90A		Z 112A		Z 140A		Z 180A		Z 225A	
ALBERO ENTRATA / INPUT SHAFT / ANTRIEBSWELLE ( $n_1 = 1400 \text{ min}^{-1}$ )												
in	a=118.25	b=98.25	a=140.25	b=115.25	a=155.25	b=125.25	a=203.75	b=163.75	a=253.75	b=213.75	a=281.25	b=226.25
	Fr <sub>1</sub>	Fa <sub>1</sub>	Fr <sub>1</sub>	Fa <sub>1</sub>	Fr <sub>1</sub>	Fa <sub>1</sub>	Fr <sub>1</sub>	Fa <sub>1</sub>	Fr <sub>1</sub>	Fa <sub>1</sub>	Fr <sub>1</sub>	Fa <sub>1</sub>
<b>Tutti All Alle</b>	400	80	630	125	1000	200	1600	320	2500	500	4000	800
ALBERO USCITA / OUTPUT SHAFT / ABTRIEBSWELLE ( $n_1 = 1400 \text{ min}^{-1}$ )												
in	a=114.5	b=84.5	a=131	b=95	a=161.5	b=113.5	a=192	b=132	a=236.5	b=162	a=325	b=220
	Fr <sub>2</sub>	Fa <sub>2</sub>	Fr <sub>2</sub>	Fa <sub>2</sub>	Fr <sub>2</sub>	Fa <sub>2</sub>	Fr <sub>2</sub>	Fa <sub>2</sub>	Fr <sub>2</sub>	Fa <sub>2</sub>	Fr <sub>2</sub>	Fa <sub>2</sub>
<b>4</b>	2550	510	4000	800	6450	1290	10150	2030	—	—	—	—
<b>5</b>	2700	540	4250	850	6800	1360	10700	2140	17250	3450	34500	6900
<b>6.3</b>	2850	570	4500	900	7150	1430	11250	2250	—	—	—	—

	Z 80B		Z 100B		Z 125B		Z 160B		Z 180B		Z 200B	
ALBERO ENTRATA / INPUT SHAFT / ANTRIEBSWELLE ( $n_1 = 1400 \text{ min}^{-1}$ )												
in	a=118.25	b=98.25	a=140.25	b=115.25	a=155.25	b=125.25	a=203.75	b=163.75	a=231.75	b=191.75	a=253.75	b=213.75
	Fr <sub>1</sub>	Fa <sub>1</sub>	Fr <sub>1</sub>	Fa <sub>1</sub>	Fr <sub>1</sub>	Fa <sub>1</sub>	Fr <sub>1</sub>	Fa <sub>1</sub>	Fr <sub>1</sub>	Fa <sub>1</sub>	Fr <sub>1</sub>	Fa <sub>1</sub>
<b>Tutti All Alle</b>	400	80	630	125	1000	200	1600	320	2000	500	2500	500
ALBERO USCITA / OUTPUT SHAFT / ABTRIEBSWELLE ( $n_1 = 1400 \text{ min}^{-1}$ )												
in	a=131	b=95	a=161.5	b=113.5	a=192	b=132	a=236.5	b=162	a=265.5	b=191	a=325	b=220
	Fr <sub>2</sub>	Fa <sub>2</sub>	Fr <sub>2</sub>	Fa <sub>2</sub>	Fr <sub>2</sub>	Fa <sub>2</sub>	Fr <sub>2</sub>	Fa <sub>2</sub>	Fr <sub>2</sub>	Fa <sub>2</sub>	Fr <sub>2</sub>	Fa <sub>2</sub>
<b>8</b>									26800	5360	38000	7600
<b>10</b>	4750	950	7500	1500	11800	2360	19000	3800	28800	5760	40000	8000
<b>12.5</b>	5000	1000	8000	1600	12500	2500	20000	4000	30400	6080	42400	8480
<b>16</b>	5300	1060	8500	1700	13200	2640	21200	4240	32200	6440	44800	8960
<b>20</b>	5600	1120	9000	1800	14000	2800	22400	4480	34000	6800	47200	9440
<b>25</b>	6000	1200	9500	1900	15000	3000	23600	4720	35800	7160	50000	10000
<b>31.5</b>	6300	1260	10000	2000	16000	3200	25000	5000	37600	7520	53000	10600

	Z 80C		Z 100C		Z 125C		Z 160C		Z 180C		Z 200C	
ALBERO ENTRATA / INPUT SHAFT / ANTRIEBSWELLE ( $n_1 = 1400 \text{ min}^{-1}$ )												
in	a=115.5	b=100.05	a=135.75	b=115.75	a=167.75	b=142.75	a=195.25	b=165.25	a=226.75	b=196.75	a=263.75	b=223.75
	Fr <sub>1</sub>	Fa <sub>1</sub>	Fr <sub>1</sub>	Fa <sub>1</sub>	Fr <sub>1</sub>	Fa <sub>1</sub>	Fr <sub>1</sub>	Fa <sub>1</sub>	Fr <sub>1</sub>	Fa <sub>1</sub>	Fr <sub>1</sub>	Fa <sub>1</sub>
<b>Tutti All Alle</b>	315	60	400	80	630	125	1000	400	1250	250	1600	320
ALBERO USCITA / OUTPUT SHAFT / ABTRIEBSWELLE ( $n_1 = 1400 \text{ min}^{-1}$ )												
in	a=131	b=95	a=161.5	b=113.5	a=192	b=132	a=236.5	b=162	a=265.5	b=191	a=325	b=220
	Fr <sub>2</sub>	Fa <sub>2</sub>	Fr <sub>2</sub>	Fa <sub>2</sub>	Fr <sub>2</sub>	Fa <sub>2</sub>	Fr <sub>2</sub>	Fa <sub>2</sub>	Fr <sub>2</sub>	Fa <sub>2</sub>	Fr <sub>2</sub>	Fa <sub>2</sub>
<b>Tutti All Alle</b>	7500	1500	11800	2360	19000	3800	30000	6000	43000	8600	53000	10600

I carichi radiali indicati nelle tabelle si intendono applicati a metà della sporgenza dell'albero e sono riferiti ai riduttori operanti con fattore di servizio 1.

The radial loads reported in the tables are considered to be applied at the half-way point of the shaft projection and refer to gear units operating with service factor 1.

Die in den Tabellen angegebenen Radialbelastungen gelten für Ansatzpunkte in der Mitte des herausragenden Wellenteils und für Getriebe mit Betriebsfaktor 1.



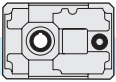

## ZA..B - ZF..B

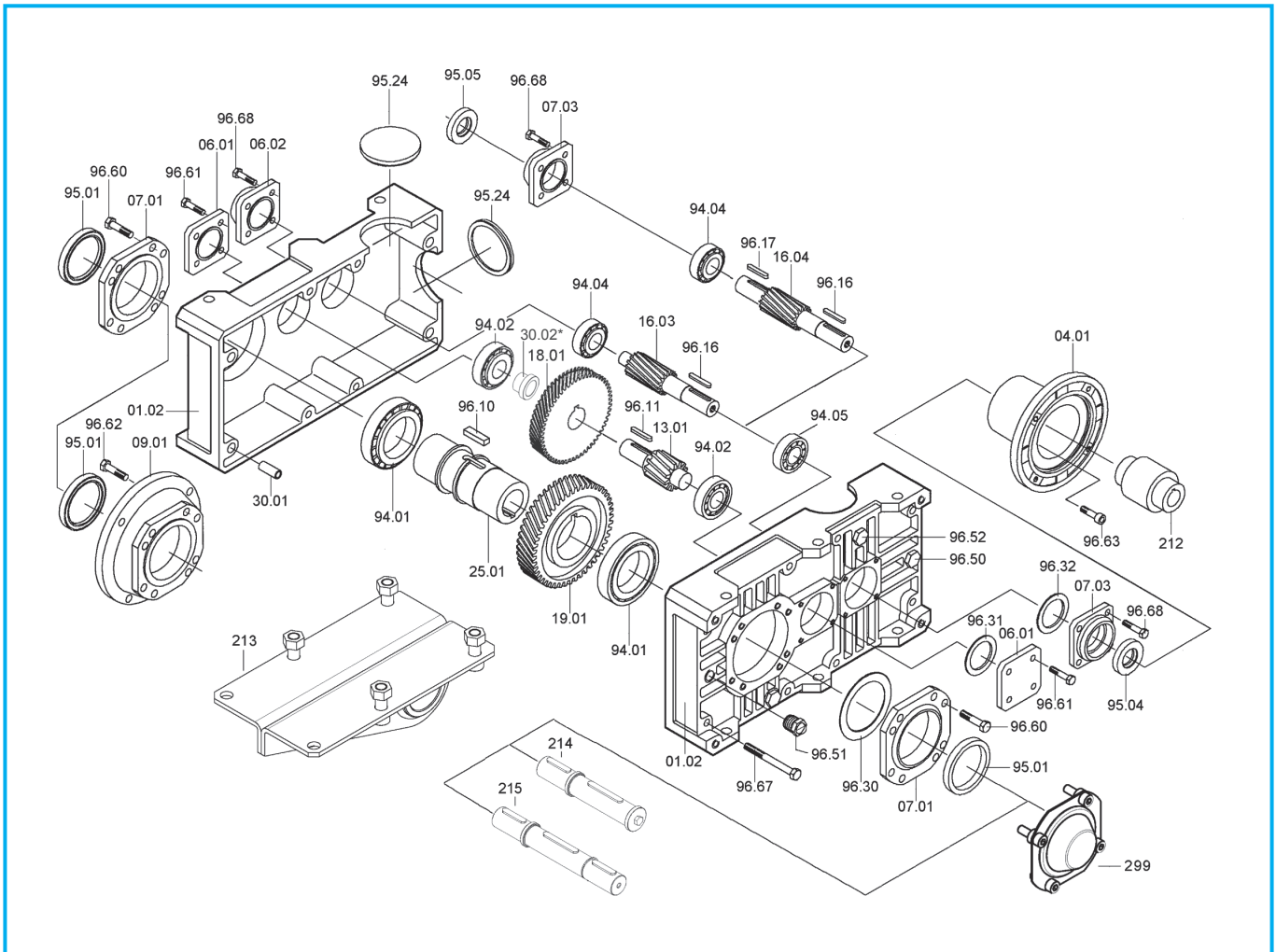

ZA - ZF	Cuscinetti / Bearings / Lager				Anelli di tenuta / Oilseals / Öldichtungen		
	94.01	94.02	94.04	94.05	95.01	95.04	95.05
<b>80B</b>	<b>32010</b> 50/80/20	<b>30204</b> 20/47/15.25	<b>30302</b> 15/42/14.25	<b>32004</b> 20/42/15	50/65/8	<b>20/40/7</b>	<b>15/40/10</b>
<b>100B</b>	<b>32012</b> 60/95/23	<b>30305</b> 25/62/18.25	<b>30204</b> 20/47/15.25	<b>32005</b> 25/47/15	60/80/10	<b>25/47/7</b>	<b>20/47/7</b>
<b>125B</b>	<b>32015</b> 75/115/25	<b>32206</b> 30/62/21.25	<b>30305</b> 25/62/18.25	<b>30206</b> 30/62/17.25	75/95/10	<b>30/52/7</b>	<b>25/52/7</b>
<b>160B</b>	<b>32019</b> 95/145/32	<b>32207</b> 35/72/24.25	<b>32206</b> 30/62/21.25	<b>32008</b> 40/68/19	95/125/12	<b>40/56/8</b>	<b>30/56/10</b>
<b>180B</b>	<b>32024</b> 120/180/38	<b>31309</b> 45/100/27.25	<b>30307</b> 35/80/22.75	<b>32208</b> 40/80/24.75	120/160/15	<b>40/62/7</b>	<b>35/62/7</b>
<b>200B</b>	<b>32026</b> 130/200/45	<b>31310</b> 50/110/29.25	<b>32208</b> 40/80/24.75	<b>32010</b> 50/80/20	130/160/12	<b>50/65/8</b>	<b>40/65/10</b>

\*Solo per Z180B / Only for Z180B / Nur für Z180B



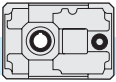

## ZA..B - ZF..B - ZA..C - ZF..C

Dispositivo antiritorno - Backstop device - Rücklaufsperr

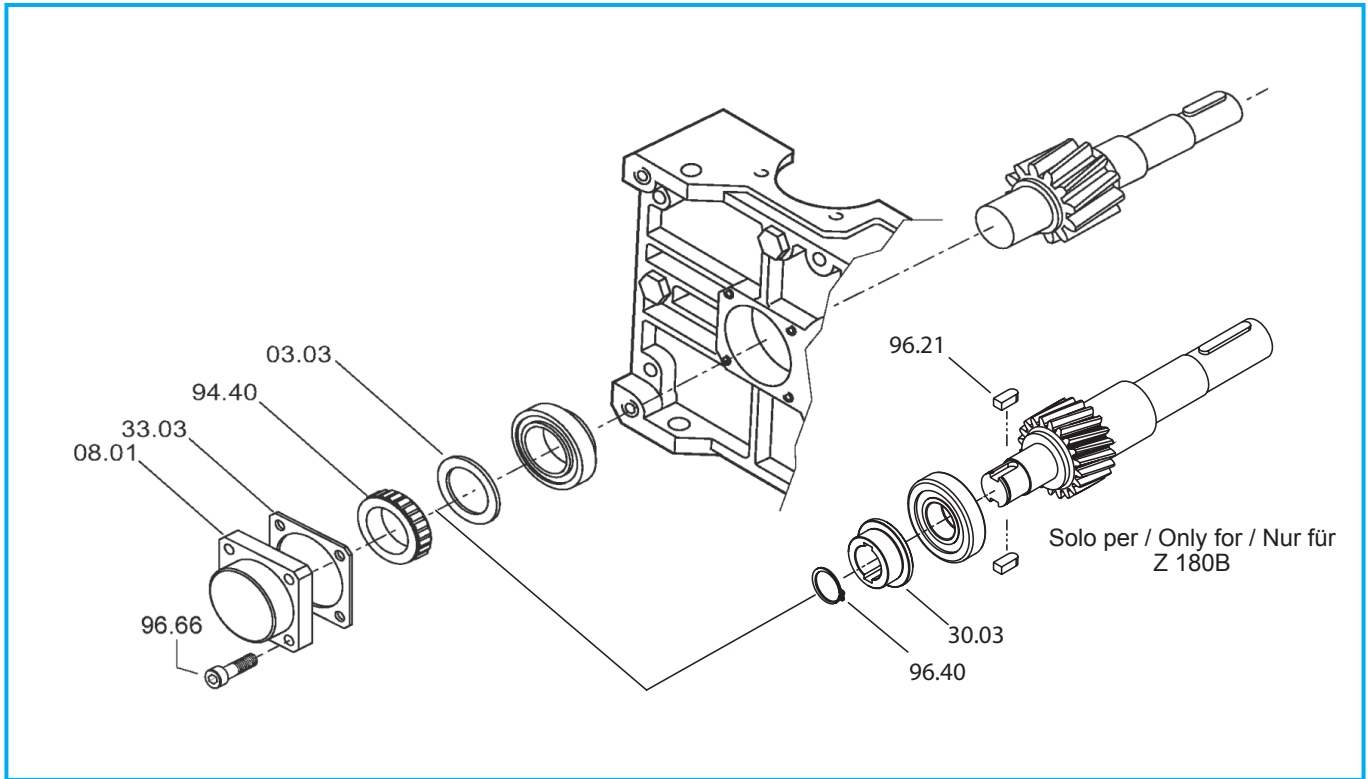

Z...B	Ruota libera / Free wheel / Freilauf 94.40
80	FE 423 Z
100	FE 428 Z
125	BF 50 Z 16
160	BF 70 Z 21
180	FE 8049 Z 19
200	FE 8040 Z 19

Z...C	Ruota libera / Free wheel / Freilauf 94.40
80	FE 423 Z2
100	FE 423 Z
125	FE 428 Z
160	BF 50 Z 16
180	BF 50 Z 16
200	BF 70 Z 21

In fase di ordine delle parti di ricambio, specificare sempre n° particolare (vedi disegno esploso), data (1), n° codice (2) e n° variante (3). (Vedi targhetta).

When ordering a spare part, the spare part number (see exploded technical drawing), the date (1), the code number (2) and the variant number (3) should always be reported. (See plate)

Bei der Bestellung von Ersatzteilen sind Ersatzteilnummer (s. Explosionszeichnung), Datum (1), Artikelnummer (2) und Variantennummer (3) anzugeben. (s. Schild)

TIPO: descrizione  
TYPE: description  
TYP: Bezeichnung

RAP: rapporto di riduzione  
RATIO: reduction ratio  
ÜBERS.: Untersetzungsverhältnis

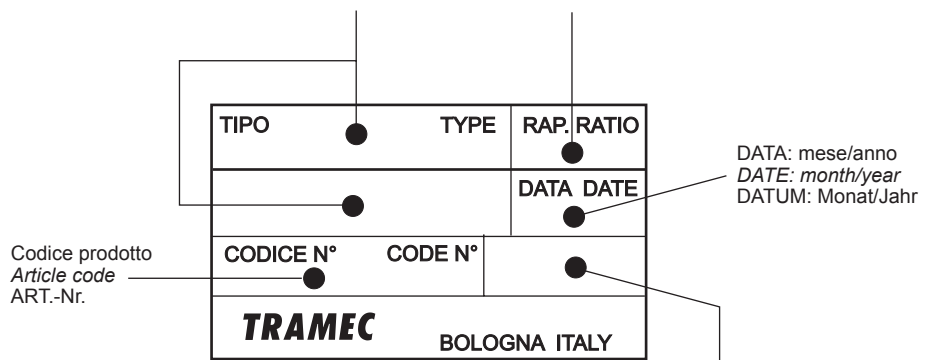

VARIANTE: codice alfanumerico  
VARIANT: alphanumeric code  
VARIANTE: alphanumerische Nummer

