

## Product Outlook

### Performance Features

- Advanced motor control algorithm
- High performance open loop vector control
- Optimal V/F mode
- Excellent ramp slope control
- Fast auto-tune (less than 1 minute)
- Overload:
  - 150% rated output current, 1 minute
- Low frequency torque:
  - 0.5Hz: 100% rated torque
  - 1Hz: 150% rated torque

### The Main Hardware Features

- Dual CPU processing, more precise control
- Standard configuration 5-digit LED keypad, standard RJ45 Keypad connector
- 5.5 kW and above with standard DC choke
- 22kW and below with standard internal brake unit
- Above 22kW models, if the internal brake unit fitted or not, could be selected by the model reference
- Internal EMC filter with breakpoint design, convenient for access and disconnection, meet different application requirements
- PCBA coating process, increase environment adaptability
- Unique control terminals: simple electronic switch set to complete the conversion between source and sink of I/O terminals
- Reference (current) loose, trip or not could be selected
- IGBT thermal design
- Wireless fan block design, easy to replace or maintain
- Connecting auxiliary fan makes the drive suitable for worse environment



# SHD700 AC Drives



## Product Outlook

### The Main Function Features

- Balance on easy use and powerful function
- Powerful programmable platform makes users program easier
  - Built-in advanced function blocks:
    - 2 threshold control blocks
    - 2 logic control blocks
    - 3 variable selectors
    - brake logic control block
- Programmable I/O terminals
- Internal energy meter, the user calculate energy saving conveniently
- Low DC voltage operation mode (380V products can work on 220V power supply )
- The stop mode can be controlled when power off
- AVR
- Switching frequency automatic adjustment
- Catch spinning function
- Injection braking
- Jump frequency control function
- Keypad disconnected trip could be controlled
- Powerful electronic potentiometer function, adjust reference conveniently
- Standard serial comms. and optional fieldbus
- The comprehensive warning and protection function:
  - Fast protection for output shortage, over current, over load, over voltage, under voltage, phase loss, over heat (heatsink and junction), external trip, etc.
  - Motor heat protection from terminals
- Warning information display or not could be selected
- Preset speed select, 16 preset speeds (decided by control terminals)
- PID control
- User define V/F:
  - 3 point line setting
  - 1.2 law ramp
  - 1.7 law ramp
  - 2.0 law ramp
- Automatic sleep mode function
- Textile function
- Pulse counting
- Length control

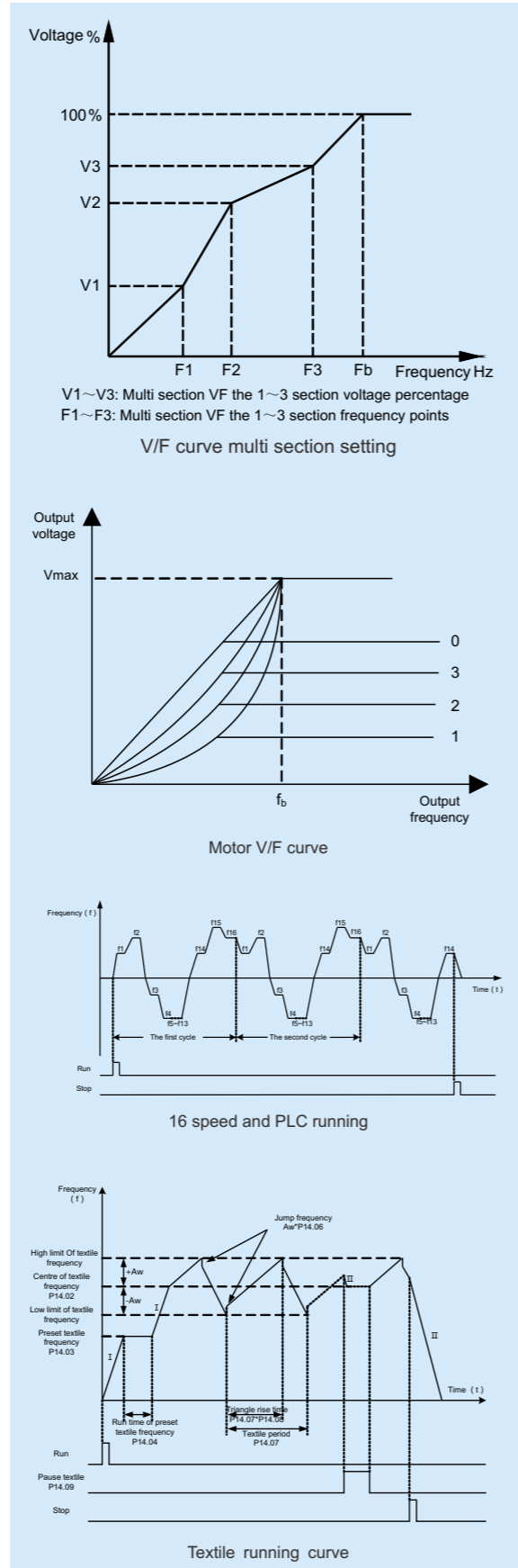

## Logic Diagram

The design of logic diagram makes the user understand and set parameters conveniently.

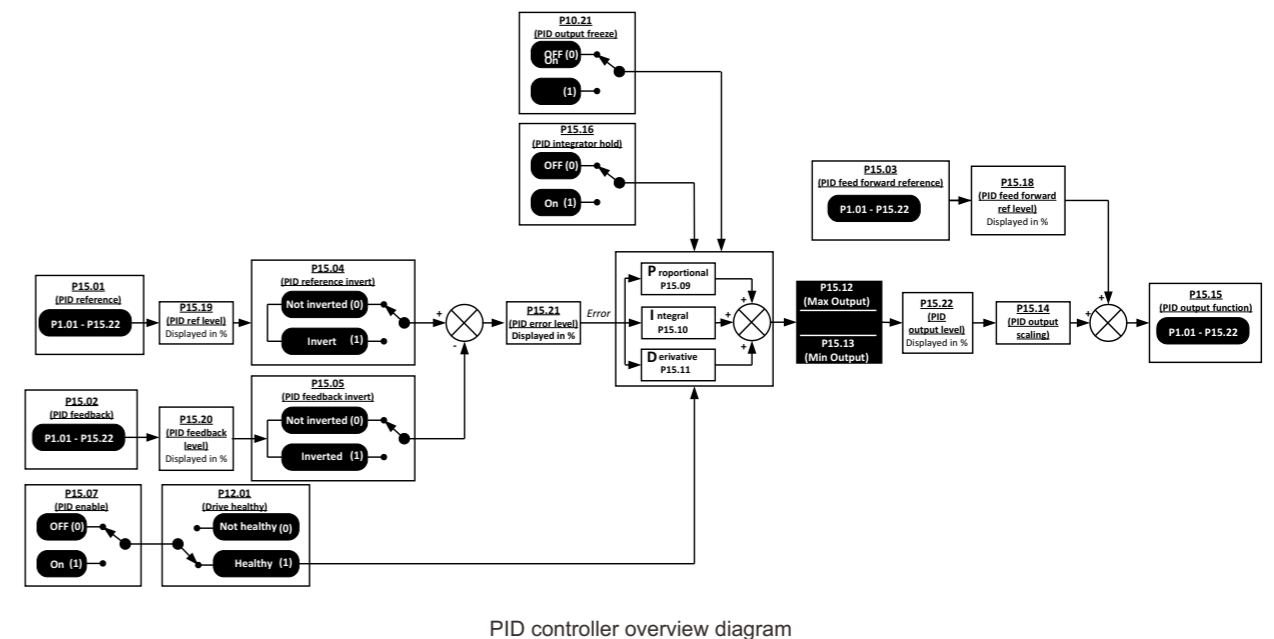
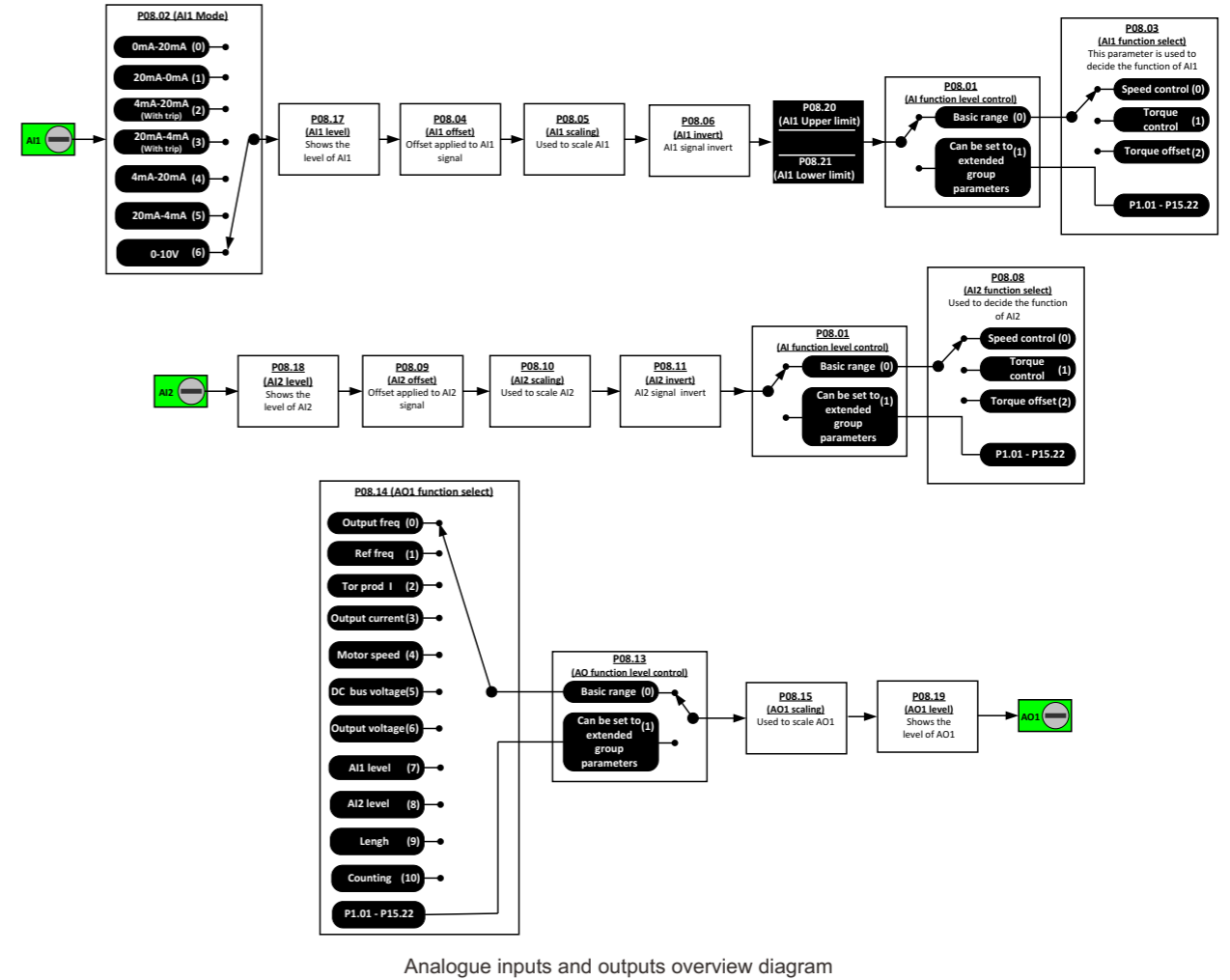

## General Technical Data

Input power	Input voltage $U_{in}$	200V (-10%)~240V (+10%) 1/3 PH 380V (-10%)~480V (+10%) 3PH 500V (-10%)~690V (+10%) 3PH
	Input frequency	50Hz/60Hz(±2Hz)
	Maximum supply imbalance	≤3%
Power output	Output voltage	0V~ $U_{in}$
	Output frequency	0Hz~300Hz
Main performance function	Voltage control	V/F, Open loop Vector Control
	Switching frequency	1kHz~15kHz
	Adjust speed range	Open loop vector control -1:100, V/F mode -1:50
	Start torque	0.5Hz: 100% rated torque 1Hz: 150% rated torque
	Torque accuracy	7%
	Reference resolution	Digital- 0.01Hz, Analogue- 0.1%×Maximum frequency
	Acce. & Dece. rate	0.1s~3600min
	Voltage boost	0.1%~30.0%
	Overload	E, G type: 150% rated output current, 1 minute P type: 110% rated output current, 1 minute
	V/F	4 types: V/F (user can program) and ramp (2.0 power, 1.7 power, 1.2 power)
	DC injection	Injection frequency: 0.0%~100.0% maximum frequency Injection current: 0.0%~300.0% rated current Injection time: 0.00s~60.00s
	Dynamic braking	The utilization rate of dynamic braking : 0.0%~100.0%
	Jog	Jog frequency: 0.00Hz~maximum frequency Jog acceleration rate: 0.1s~600.0s Jog interval time: 0.1s~600.0s
	Preset	16 preset speeds (decided by control terminals)
	AVR	Maintain the rated output voltage when the input power supply voltage changed
Special function	Textile	For textile machines control
	Simple PLC	Onboard PLC
	Length control	Winding control
	PID control	Process control (reference close loop control)
	Advanced function blocks	2 logic control blocks 1 binary selector 2 threshold control blocks 3 variable selectors

## General Technical Data

Control terminal	Reference source	Digit: Keypad, motorized pot (E-Pot), pulse, comms. Analogue: AI1: 0V~10V, 0(4) mA~20mA; AI2: 0V~10V
	Operating mode	Keypad, Control terminal, Serial comms.
	Digital input terminals	DI1~DI7: Programmable terminals and DI6 can be set as pulse input, 0Hz~60Hz; DI7 can be high frequency pulse input (1Hz~50.0kHz) or PTC thermistor input
	Digital output terminals	DO1~DO2: Programmable terminals, Max. output current: 50mA, DO2 can be the terminal to output pulse ( 0.1kHz~50.0kHz ), and output PWM
	Analogue output Terminals	AO1: programmable terminal, 0V~10V
	Status relay	2 programmable relays, contactor data: AC250V/2A (COS φ=1) AC250V/1A (COS φ=0.4) DC30V/1A
Comms.	Connector	2 terminals (A&B) and RJ45 port
	Protocol	Modbus RTU
Environment	Altitude	1000m rated 1000m~3000m, 1% rated current derating per 100m
	Operating temperature	-10℃~+40℃
	Maximum humidity	≤90%RH, no-condensing
	Vibration	≤5.9m/s <sup>2</sup> (0.6g)
	Storage temperature	-40℃~+70℃
	Running environment	Indoor, non-flammable, no corrosive gasses, no contamination with electrically conductive material, avoid dust which may restrict the fan
Optional module	LCD Keypad, HDOM-232, HDOM-USB, Profibus module, Keypad pallet, HDSOFT (PCTools), etc.	
Protection	Output shortage, over current, over load, over voltage, under voltage, phase loosing, over heat (heatsink and junction), external trip, etc.	
Efficiency	1.5kW and below: ≥89% 2.2kW~22kW: ≥93% 30kW and above: ≥95%	
Mounting method	Surface mounting, through hole, cubicle standing	
Enclosure	IP 20, IP21 (by adding optional device)	
Cooling method	220V/ 0.4kW model is nature cool, others are forced air cool	

# SHD700 AC Drives

## Model Reference

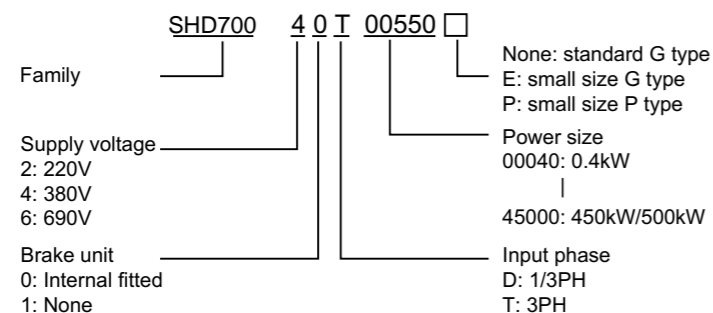

Power size of HD700 is referred to the standard 4 poles induction motor at rated voltage.

E, G: Heavy duty P: Normal duty

Overload of E, G type: 150% rated output current, 1 minute

Overload of P type: 110% rated output current, 1 minute

## 200V - 220V Rating Data

Power supply: 200Vac~240Vac, 50Hz/60Hz, single/three phase

Model Name	Motor Power (kW)	Drive Power Size (kVA)	Rated Input Current (A)		Rated Output Current (A)	Default Carrier Frequency (kHz)	Size
			1/3PH				
SHD70020D00040	0.4	1.1	7.1/4		2.8	6	A
SHD70020D00075	0.75	1.9	12.8/7.1		5	6	A
SHD70020D00150	1.5	3.0	20.5/11.3		8	6	A
SHD70020D00220	2.2	4.2	24/14.5		11	6	B
SHD70020D00400	4	6.7	16.5		17.6	6	C

## 380V - 480V Rating Data

Power supply: 380Vac~480Vac, 50Hz/60Hz, three phase

Model Name	Default Carrier Frequency (KHz)	G				P				Size
		Motor Power (kW)	Rated Input Current (A)	Rated Output Current (A)	Drive Power Size (kVA)	Motor Power (kW)	Rated Input Current (A)	Rated Output Current (A)	Drive Power Size (kVA)	
SHD70040T00075	6	0.75	3.6	2.5	1.7	-	-	-	-	A
SHD70040T00150	6	1.5	5.7	4.2	2.8	-	-	-	-	A
SHD70040T00220E	6	2.2	6.1	5.2	3.4	-	-	-	-	A
SHD70040T00220	6	2.2	8.3	5.8	3.8	-	-	-	-	B
SHD70040T00400	6	3.7	13.2	9.5	6.3	-	-	-	-	B
SHD70040T00550E	6	5.5	14.3	13	8.6	-	-	-	-	B
SHD70040T00550P	6	-	-	-	-	5.5	14.3	13	8.6	B
SHD70040T00550	6	5.5	12.4	13	8.6	-	-	-	-	C
SHD70040T00750	6	7.5	16.1	17	11	-	-	-	-	C
SHD70040T01100P	6	-	-	-	-	11	21	23	15.2	C
SHD70040T01100	6	11	24	25	16.5	15	31	32	21	D
SHD70040T01500		15	31	32	21	18.5	36	38	25	D
SHD70040T01850		18.5	36	38	25	22	44		30	E
SHD70040T02200		22	44	46	30	30	58	60	40	E
SHD70040T03000E	3	30	58	60	40	37	72	75	50	E1
SHD70040T03700E		37	72	75	50	-	-	-	-	E1
SHD70040T03000	3	30	58	60	40	37	72	75	50	F
SHD70040T03700	3	37	72	75	50	45	93	96	63	F

## 380V - 480V Rating Data

Power supply: 380Vac~480Vac, 50Hz/60Hz, three phase

Model Name	Default Carrier Frequency (KHz)	G				P				Size
		Motor Power (kW)	Rated Input Current (A)	Rated Output Current (A)	Drive Power Size (kVA)	Motor Power (kW)	Rated Input Current (A)	Rated Output Current (A)	Drive Power Size (kVA)	
SHD70040T04500	3	45	93	96	63	55	121	125	83	F
SHD70040T05500	3	55	121	125	83	75	151	156	103	F
SHD70040T07500	3	75	151	156	103	90	175	180	119	F
SHD70040T09000	3	90	175	180	119	110	204	210	139	G
SHD70040T11000	3	110	204	210	139	132	248	256	169	G
SHD70040T13200	3	132	248	256	169	160	301	310	205	G
SHD70040T16000E	3	160	301	310	205	185	340	350	231	J
SHD70040T18500E	3	185	340	350	231	200	375	387	255	J
SHD70040T20000E	3	200	375	387	255	220	415	427	280	J
SHD70040T16000	3	160	301	310	205	185	340	350	231	K
SHD70040T18500	3	185	340	350	231	200	375	387	255	K
SHD70040T20000	3	200	375	387	255	250	457	471	310	K
SHD70040T25000	3	250	457	471	310	280	505	520	343	K
SHD70040T28000	3	280	505	520	343	315	592	610	403	K
SHD70040T31500	2	315	592	610	403	355	653	673	444	L
SHD70040T35500	2	355	653	673	444	400	728	750	495	L
SHD70040T40000	2	400	728	750	495	450	810	835	551	L
SHD70040T45000	2	450	810	835	551	500	915	943	622	L

## 500V - 690V Rating Data

Power supply: 500Vac~690Vac, 50Hz/60Hz, three phase

Model Name	Default Carrier Frequency (KHz)	G				P				Size
		Motor Power (kW)	Rated Input Current (A)	Rated Output Current (A)	Drive Power Size (kVA)	Motor Power (kW)	Drive Power Size (kVA)	Rated Output Current (A)	Drive Power Size (kVA)	
SHD70060T03000	3	30	36	36	43	37	49	51	51	F
SHD70060T03700	3	37	49	51	61	45	52	54	65	F
SHD70060T04500	3	45	52	54	65	55	61	63	75	F
SHD70060T05500	3	55	61	63	75	75	83	86	103	F
SHD70060T075000	3	75	83	86	103	90	97	100	120	F
SHD70060T09000	3	90	97	100	120	110	127	131	157	G
SHD70060T11000	3	110	127	131	157	132	145	150	179	G
SHD70060T13200	3	132	145	150	179	160	170	175	209	G
SHD70060T16000E	3	160	170	175	209	185	192	198	237	J
SHD70060T18500E	3	185	192	198	237	200	224	231	276	J
SHD70060T20000E	3	200	224	231	276	220	235	248	296	J
SHD70060T16000	3	160	170	175	209	185	192	198	237	K
SHD70060T18500	3	185	192	198	237	200	224	231	276	K
SHD70060T20000		200		231	276	250		274	327	K
SHD70060T25000		250		274	327	280		293	350	K
SHD70060T28000		280	285	293				328		
SHD70060T31500	2	315	318	328	392	355	375	387	462	L
SHD70060T35500	2	355	375	387	462	400	413	426	509	L
SHD70060T40000	2	400	413	426	509	450	468	482	576	L
SHD70060T45000	2	450	468	482	576	500	529	545	651	L

## Diagram of Mounting

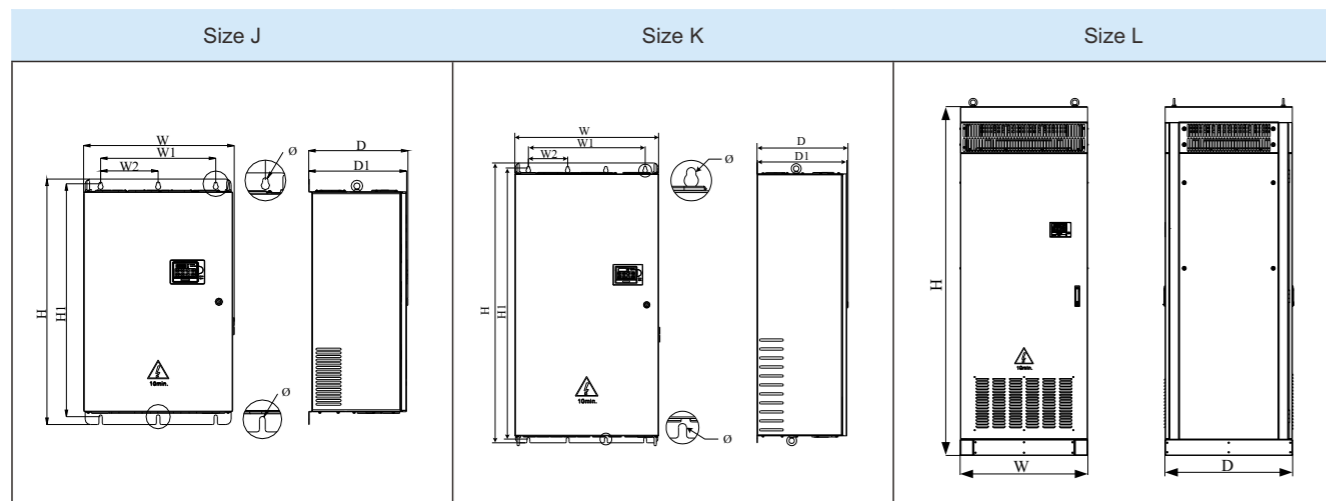
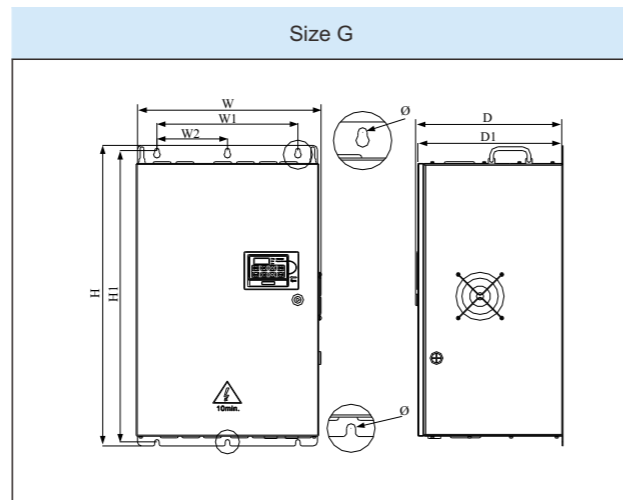
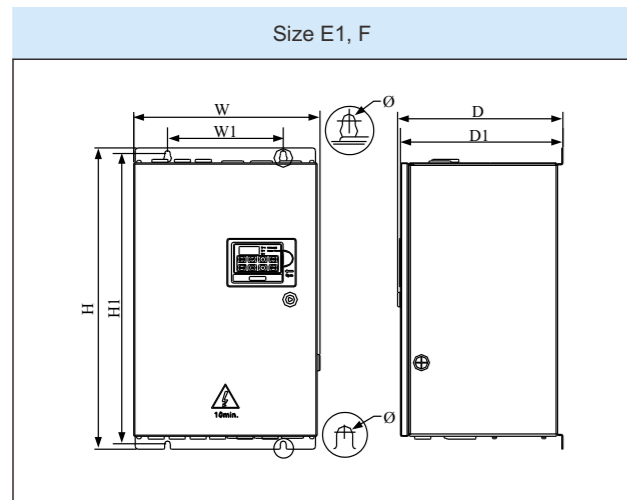
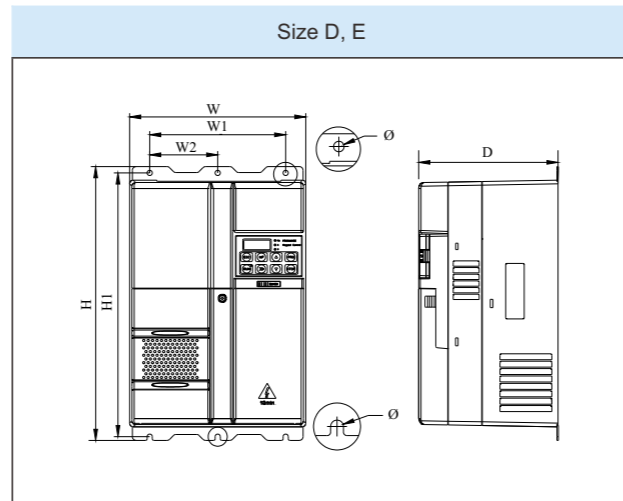
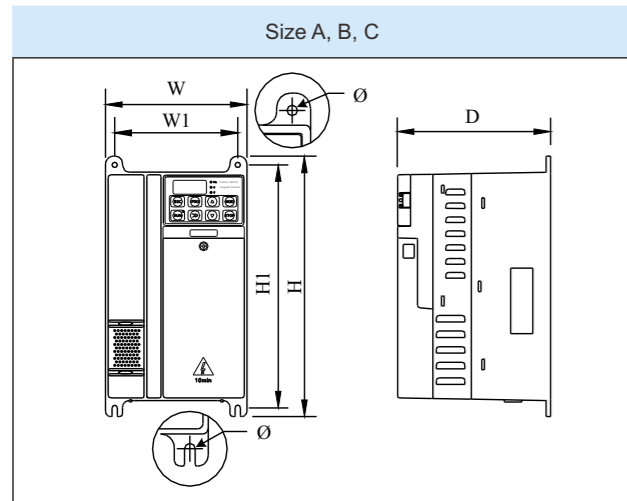

## Mechanical Dimension

Size	Model Name	W (mm)	W1 (mm)	W2 (mm)	H (mm)	H1 (mm)	D (mm)	D1 (mm)	Mounting Hole Ø (mm)	Weight (kg)	Comments
A	SHD70020D00040	97.4	80	-	202.4	190	148.8	-	5	1.4	-
	SHD70020D00075										
	SHD70020D00150										
	SHD70040T00075										
	SHD70040T00150										
B	SHD70020D00220	142.4	123.5	-	220.4	208	155.5	-	5	2.2	-
	SHD70040T00220										
	SHD70040T00400										
	SHD70040T00550E										
C	SHD70040T00550P	163.1	142	-	300	280	176.8	-	6	4.5	Internal DC choke
	SHD70040T00750										
	SHD70040T01100P										
D	SHD70040T01100	238.5	184	92	370	356.5	189	-	7	8.8	Internal DC choke
	SHD70040T01500										
E	SHD70040T01850	238.5	184	92	435.5	422	200.3	-	7	12.1	Internal DC choke
	SHD70040T02200										
E1	SHD70040T03000E	320	210	-	510	490	226	222.5	8	20	-
	SHD70040T03700E										
F	SHD70040T03000	355.5	221	-	573	552.5	315.5	310	10	40	Internal DC choke
	SHD70040T03700										Internal DC choke
	SHD70040T04500										Internal DC choke
	SHD70040T05500										External DC choke
	SHD70040T07500										External DC choke
	SHD70060T03000										Internal DC choke
	SHD70060T03700										Internal DC choke
	SHD70060T04500										Internal DC choke
	SHD70060T05500										External DC choke
SHD70060T07500	External DC choke										
G	SHD70040T09000	445.6	340	170	725	701.5	355	349.5	10	63	External DC choke
	SHD70040T11000										
	SHD70040T13200										
	SHD70060T09000										
	SHD70060T11000										
J	SHD70040T16000E	575.5	440	220	937	889	379.3	373.8	13	104	External DC choke
	SHD70040T18500E										
	SHD70040T20000E										
	SHD70060T16000E										
	SHD70060T18500E										
K	SHD70060T20000E	640	520	175	1246.5	1207.5	405.5	400	13	150	External DC choke
	SHD70040T16000										
	SHD70040T18500										
	SHD70040T20000										
	SHD70040T25000										
	SHD70040T28000										
	SHD70060T16000										
	SHD70060T18500										
	SHD70060T20000										
SHD70060T25000											
SHD70060T28000											

## Mechanical Dimension

Size	Model Name	W (mm)	W1 (mm)	W2 (mm)	H (mm)	H1 (mm)	D (mm)	D1 (mm)	Mounting Hole $\varnothing$ (mm)	Weight (kg)	Comments
L	SHD70040T31500	804	-	-	2200	-	804	-	-	350	Internal AC choke
	SHD70040T35500										
	SHD70040T40000										
	SHD70040T45000										
	SHD70060T31500										
	SHD70060T35500										
	SHD70060T45000										

## Typical Cabling

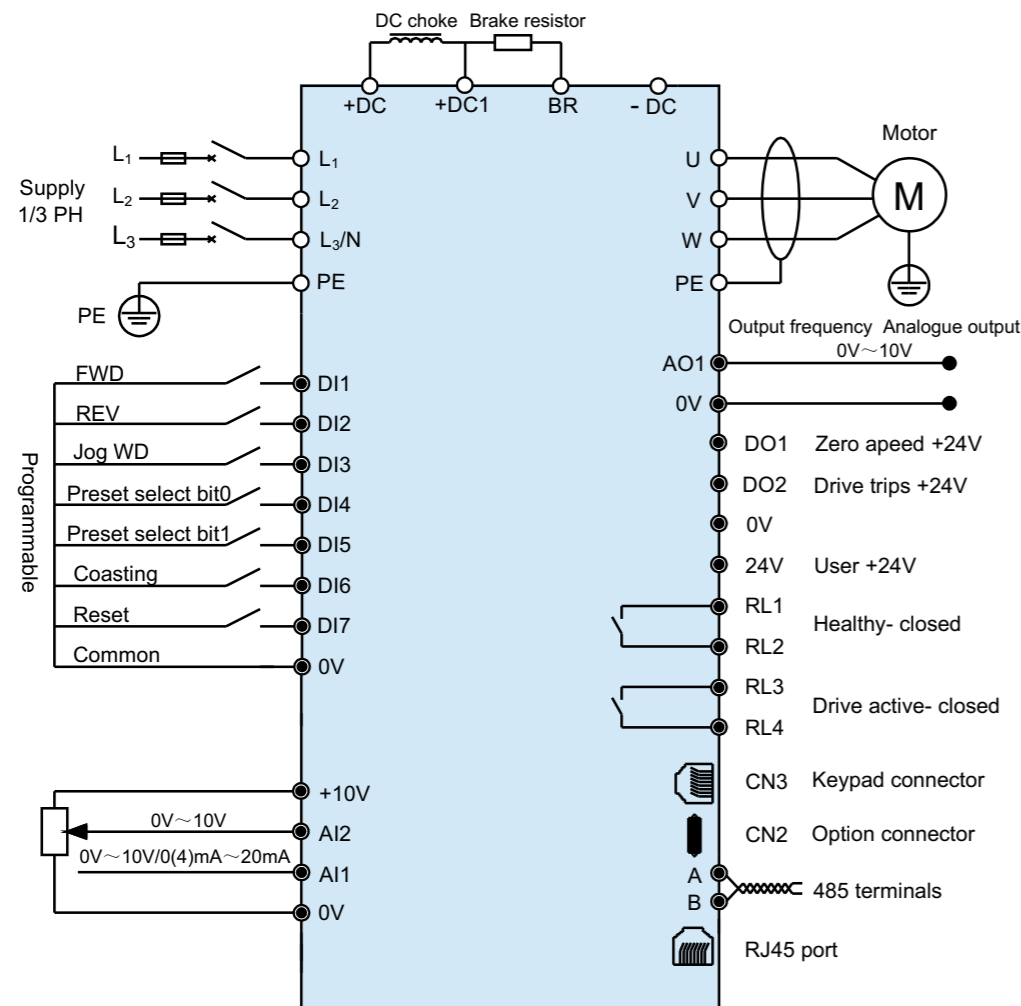

### Note:

- All the programmable control terminal functions are factory default set;
- For control wire, recommend using unshielded twisted pair, shielded cable or shielded twisted pair;
- 5.5kW~280kW models (including 220V/4kW, except size E1 models), internal DC choke is fitted. 315kW~450kW models with AC reactor fitted.

## Control Terminal

### Control Terminal Diagram

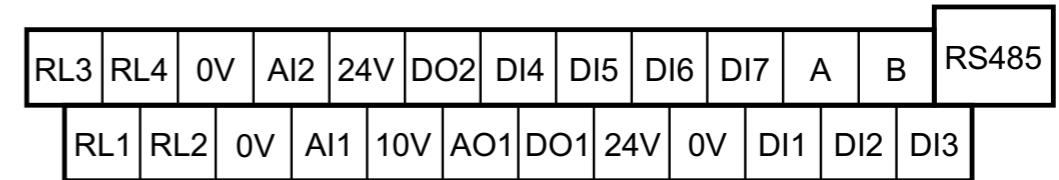

### Control Terminal And Comms. Port

Type	Terminal Name	Function	Technical Specification
Serial comms.	RS485	RJ45 port	Two lines, Modbus RTU protocol
	A	485 plus signal	Same function with RJ45 port, mainly for multi network
	B	485 minus signal	
Digit input	DI1~DI5	Programmable digital input terminals	The common can be 0V or 24V by setting the P09.21 (default is 0V) Input resistance: 10k $\Omega$ High logic threshold: 10V $\pm$ 1V Sample time: 1ms
	DI6	Normal digital input Length counting Number counting	<ul style="list-style-type: none"> <li>Same as DI1~DI5</li> <li>Length counting by input pulse Sample time: 5ms</li> <li>Number counting by input pulse Sample time: 5ms</li> </ul> Note: pulse frequency range is 0Hz~60Hz
	DI7	Normal digital input High frequency pulse input Motor thermister input	<ul style="list-style-type: none"> <li>Same as DI1~DI5, but Input resistance is 5k<math>\Omega</math></li> <li>High frequency pulse input Frequency range: 1kHz~50kHz</li> <li>Only when P09.21=1 input can be thermister Trip resistance: 3k<math>\Omega</math> Reset resistance: 1.8k<math>\Omega</math> Sample time: 5ms</li> </ul>
Digital output	DO1	Programmable digital output terminal1	Output: 24V/0V Maximum output current: 50mA Updating rate: 20ms
	DO2	Programmable digital output terminal1	<ul style="list-style-type: none"> <li>Same with DO1</li> <li>High frequency pulse output (0.1kHz~50kHz)</li> <li>PWM output (10kHz)</li> </ul>
Analogue input & output	AI1	Programmable analogue input1	0V~10V, Input resistance: 100k $\Omega$ , 0 (4) mA~20mA Load resistance:188 $\Omega$ , Minimum potentiometer resistance: 0.5k $\Omega$ Resolution: 0.1%, Accuracy: 2%, Sampling period: 5ms
	AI2	Programmable analogue input1	0V~10V, Input resistance: 30k $\Omega$ Minimum potentiometer resistance: 0.5k $\Omega$ Resolution: 0.1%, Accuracy: 2% Sampling period: 5ms
	AO1	Programmable analogue output	0V~10V, Maximum output current: 5mA, Resolution: 0.4% Accuracy: $\pm$ 5%, Update rate: 5ms
Rail supply & Relay	10V	Analogue reference rail	Accuracy: 2%, Maximum output current: 20mA
	24V	User supply (2)	Accuracy: $\pm$ 15%, Maximum output current: 100mA
	0V	Common (3)	Common reference point for control signal
	RL1, RL2	Programmable Relay1 output contactors	Type: normal open Update rate: 5ms Contactor rating: 250VAC/2A(cos $\phi$ =1); 250VAC/1A(cos $\phi$ =0.4); 30VDC/1A Default: Relay1: closed when powered and healthy Relay2: closed when drive is active
	RL3, RL4	Programmable Relay2 output contactors	

# SAMT®



Specialised Air Motors and Transmission

## TONSON®

**New South Wales**

Head Office

Unit 19/5 Lyn Parade

Prestons NSW 2170

Ph: (02) 9607 4100

Fax: (02) 9607 4200

Website: [www.tonson-motor.com.au](http://www.tonson-motor.com.au)

Email: [sales@samt.com.au](mailto:sales@samt.com.au)