



SCREW JACK
SERIES



Features

Product Features

- 1> Various applications: Screw Jack Reducer is widely used in various industries such as in Mechanical, Metallurgical, Architectural, Agricultural irrigation, Solar power energy, and etc.
- 2> Installation flexibility: Screw Jack Reducer has adjustable installation by moving upward, moving downward, auxiliary propelled, turnover, and height adjustment.
- 3> Drive ability: Screw Jack Reducer can be driven by electrical motors or other power drivers, and by manually.
- 4> Convenience of mounting: Screw Jack Reducer is offered in various types and mounting positions for diverse applications.
- 5> Stable transmission: Screw Jack Reducer is designed and used in aluminum bronze worm wheel which offers better strength, endurance, lower noise, higher reliability, and free lock.
- 6> Self-lock: Screw Jack Reducer bears irreversible function from the output shaft and makes transmitting movements safely.
- 7> Strength enhanced: the casting and covers of Screw Jack Reducer are produced in high tensile strength nodular cast iron for enhancing its strength.
- 8> Our Screw Jack is featuring a compact, versatile, and firm housing.

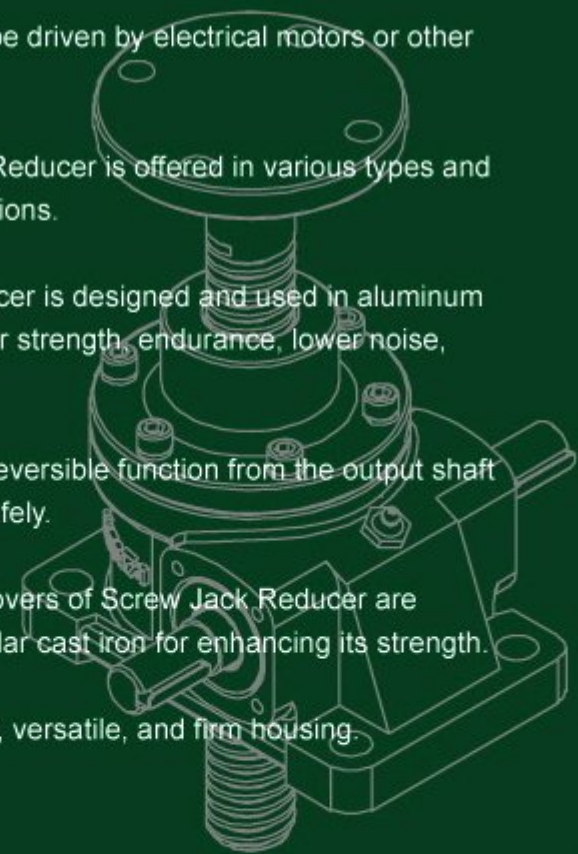

Sample Part Number

JRM — 035 — 10 — HH — A — 300 — P

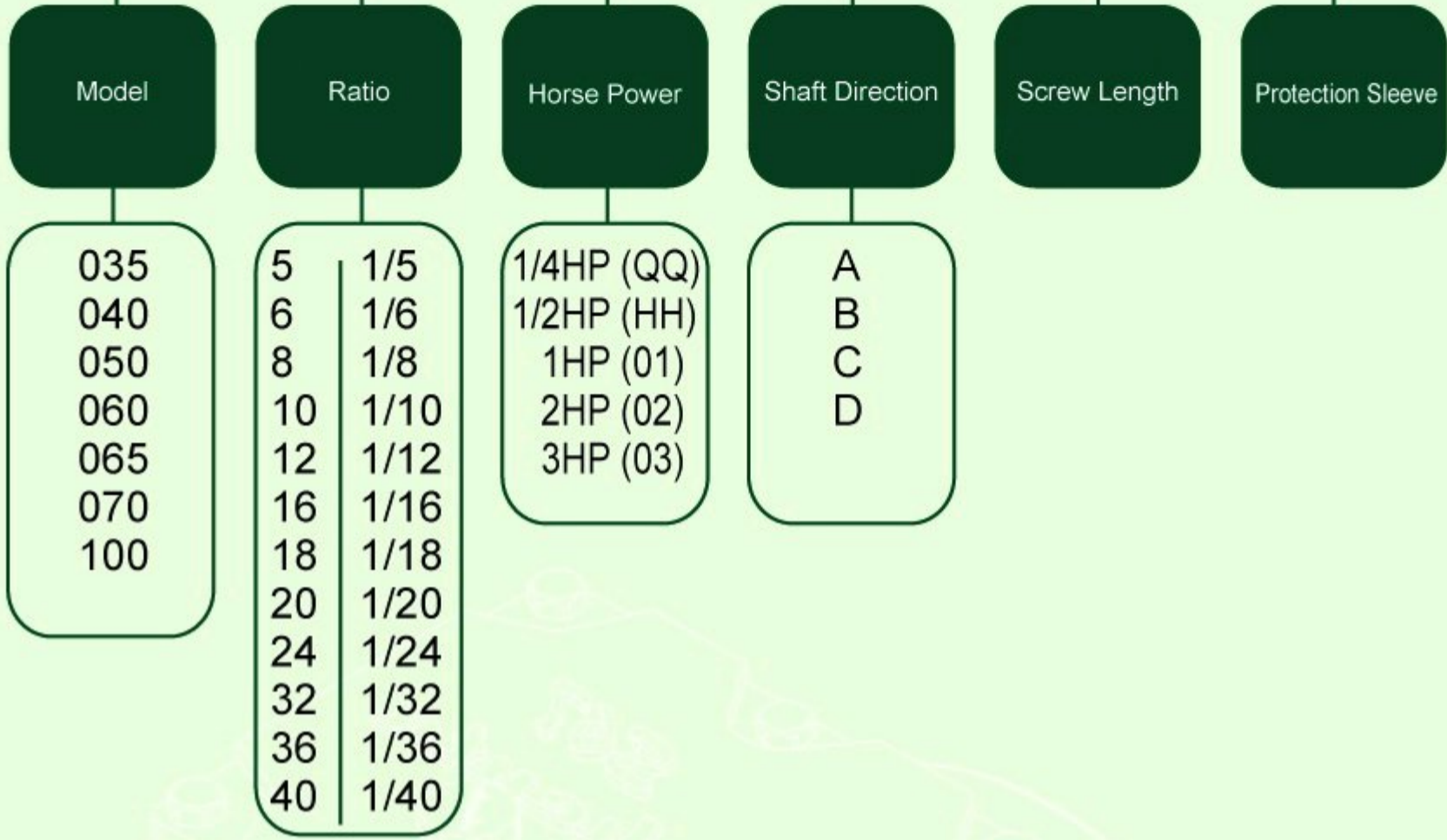

J — R — M

Type

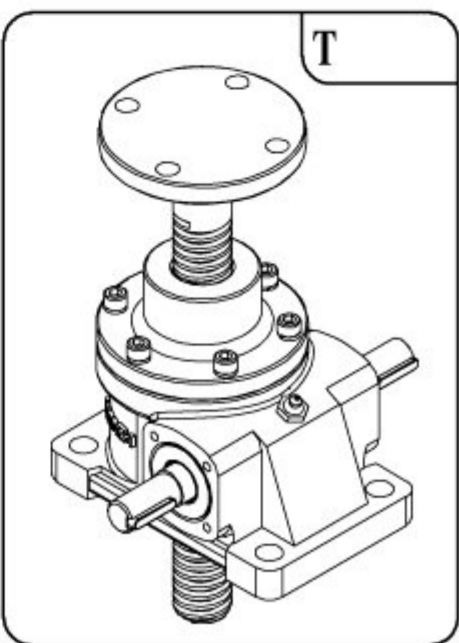
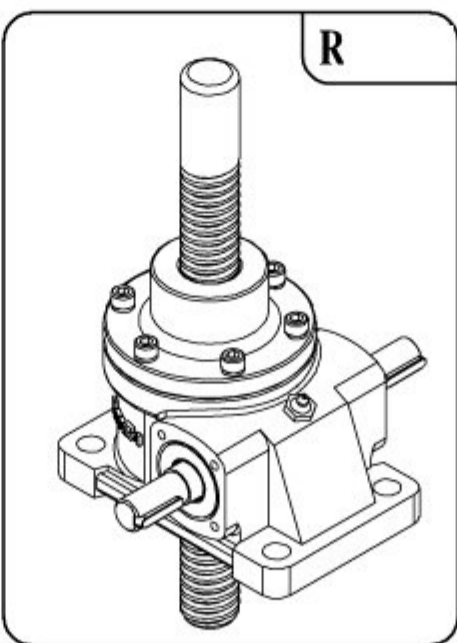
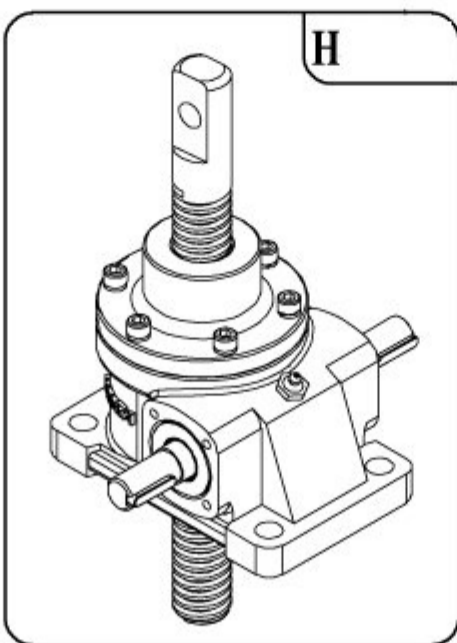
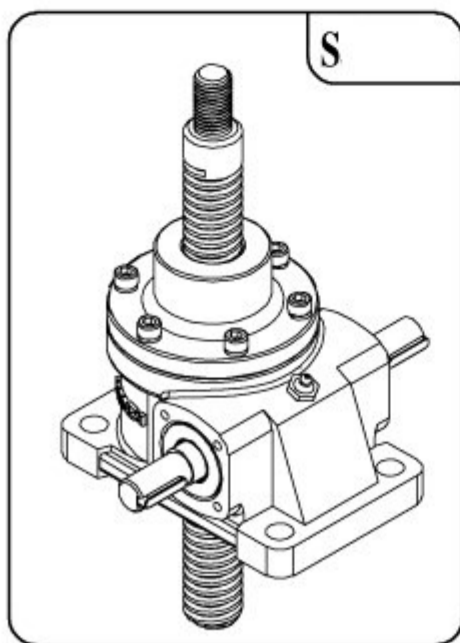
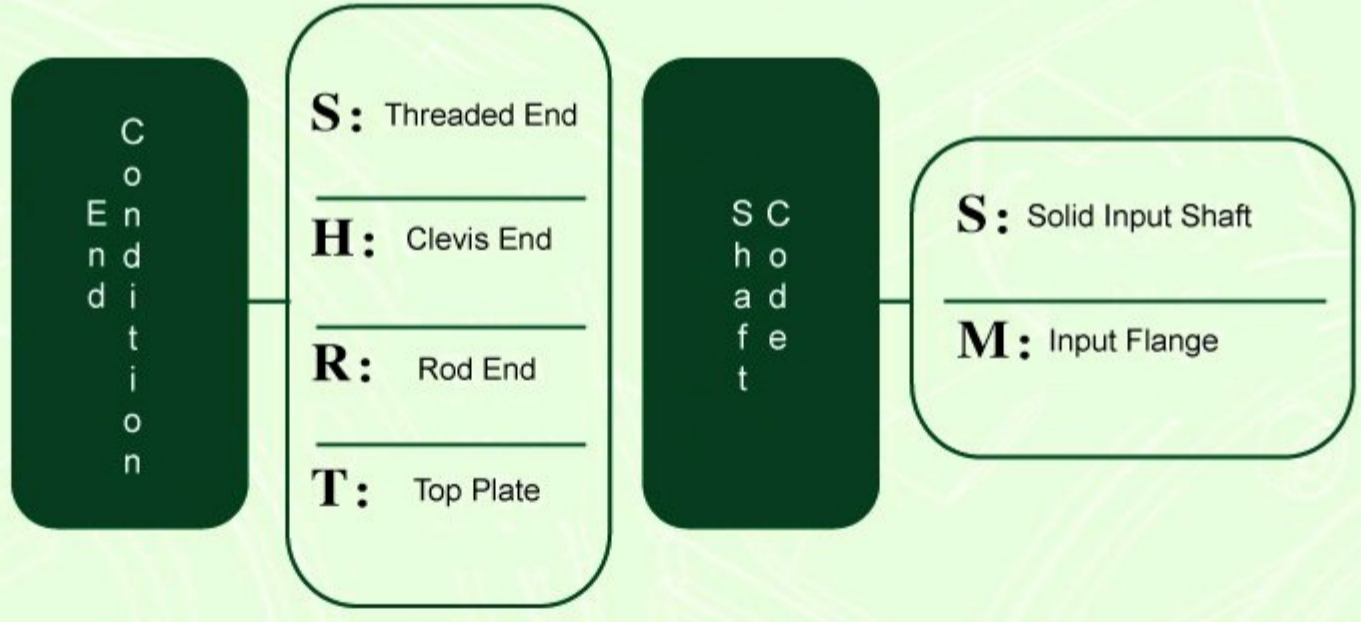

Permissible Bending Load

As for the screw length and permissible bending load for a variety of models and methods of loading at screw end, please refer to following charts and formula.

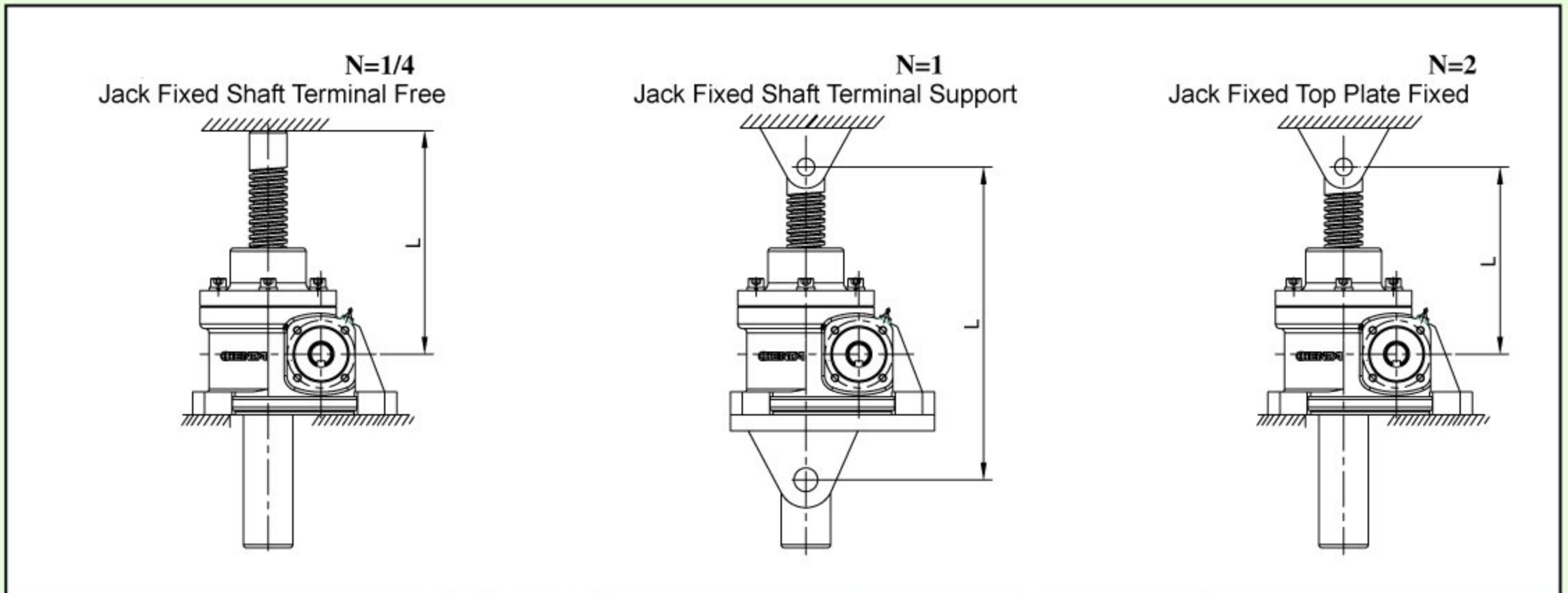

Formula:

$$P_{cr} = n \cdot \pi^2 \cdot E \cdot (K/L)^2 \cdot A \cdot \alpha$$

N: Shaft end support factor

E: Longitudinal elasticity modulus $2.1 \times 10^4 \text{ kgf/mm}^2$

K: Minimum auxiliary radius $K = d/4$

d = Minor diameter

L: Shaft support length

A: Section area of diameter for thread of lifting screw

$$A = \pi \cdot d^2 / 4$$

α : Service factor $\alpha = 0.25$

	d mm						
	35	40	50	60	65	70	100
d	19.9	25.2	31.5	35.9	42.3	53	61.5

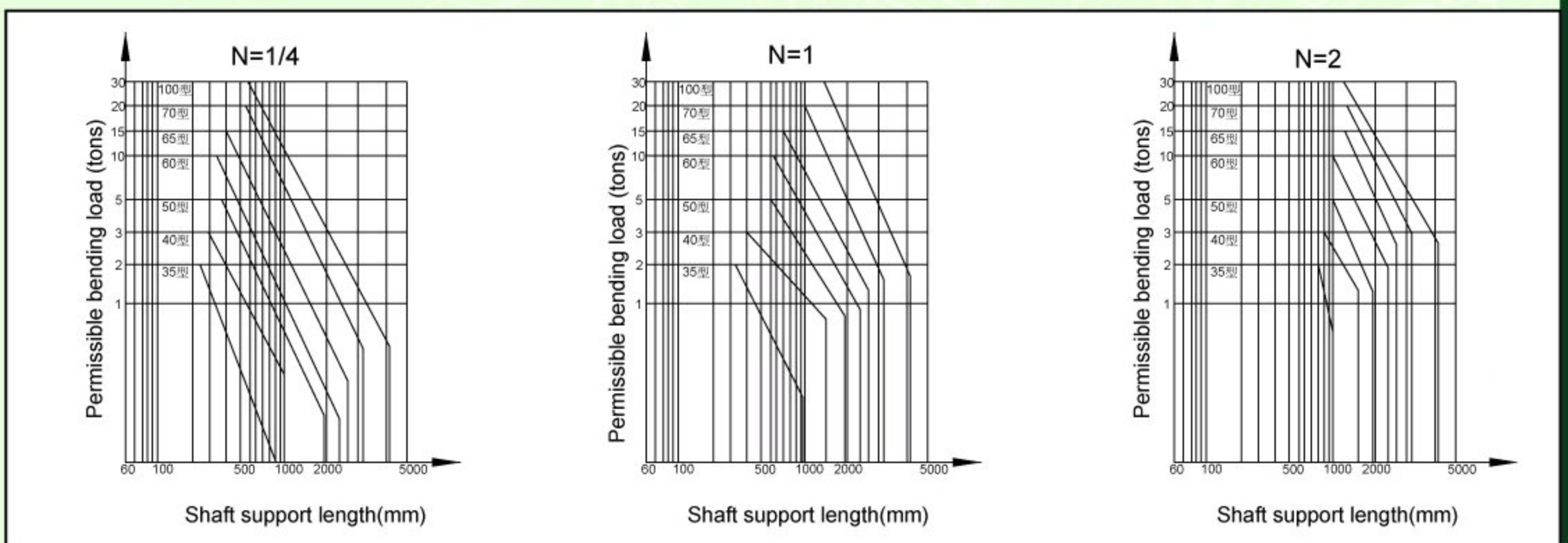

Technical Data

Reference

Formula 1:

$V = \frac{N \cdot P}{i}$	V: speed (m/min)
	N: input RPM (rpm)
	P: pitch (mm)
	i: ratio

Formula 2:

$L = \frac{Q \cdot V}{102 \cdot 60 \cdot \eta}$	L: rated input power (kw)
	Q: overhead load (kg)
	V: speed (m/min)
	η : efficiency

Table 1: load factor

Load condition	Example	Load factor
Uniform load	Valve switching device, conveyor switching device	1.0~1.3
Moderate shock load	Diverse elevators horizontally moving device	1.3~1.5
Heavy shock load	Clearance adjustment for calendar roller	1.5~3.0

Formula 3:

$$1\text{kg}\cdot\text{m} = 9.8\text{Nm}$$

$L = \frac{T \cdot N}{9550}$	L: rated input power (kw)
	T: output torque (Nm)
	N: input RPM (rpm)

Table 2: transmission efficiency

Q'ty (unit)	2	4	6	8
Transmission factor	0.9	0.8	0.7	0.7



Examples: Horsepower example for a 4-Jack-System
 Find the horsepower required to raise a system load of 3 tons, a speed of 0.45m/min, a distance of 1000mm, using four in size 40 Jacks with input shaft dia.31.75mm and pitch 6. The service factor is 1.2(refer to table 1): the load per jack is 900kg(=3000kg/4*1.2).

$$\text{(formula 1)} \quad i = \frac{N \cdot P}{V} = \frac{1800 \cdot 6}{450} = 24 \text{ (ratio)}$$

$$\text{(formula 2)} \quad L = \frac{Q \cdot V}{102 \cdot 60 \cdot \eta} = \frac{3000 \cdot 0.45}{102 \cdot 60 \cdot 0.17} = 1.29 \text{ (Kw)}$$

Refer to table 1, SF=1.2, $1.29 \cdot 1.2 = 1.548 \text{ (KW)}$

Refer to table 2, transmission factor=0.8, $1.548 / 0.8 = 1.935 \text{ (kw)}$ $\approx 3 \text{ (HP)}$

→Select 3HP, 4P motor

Remark: above example is subject to a reference only.

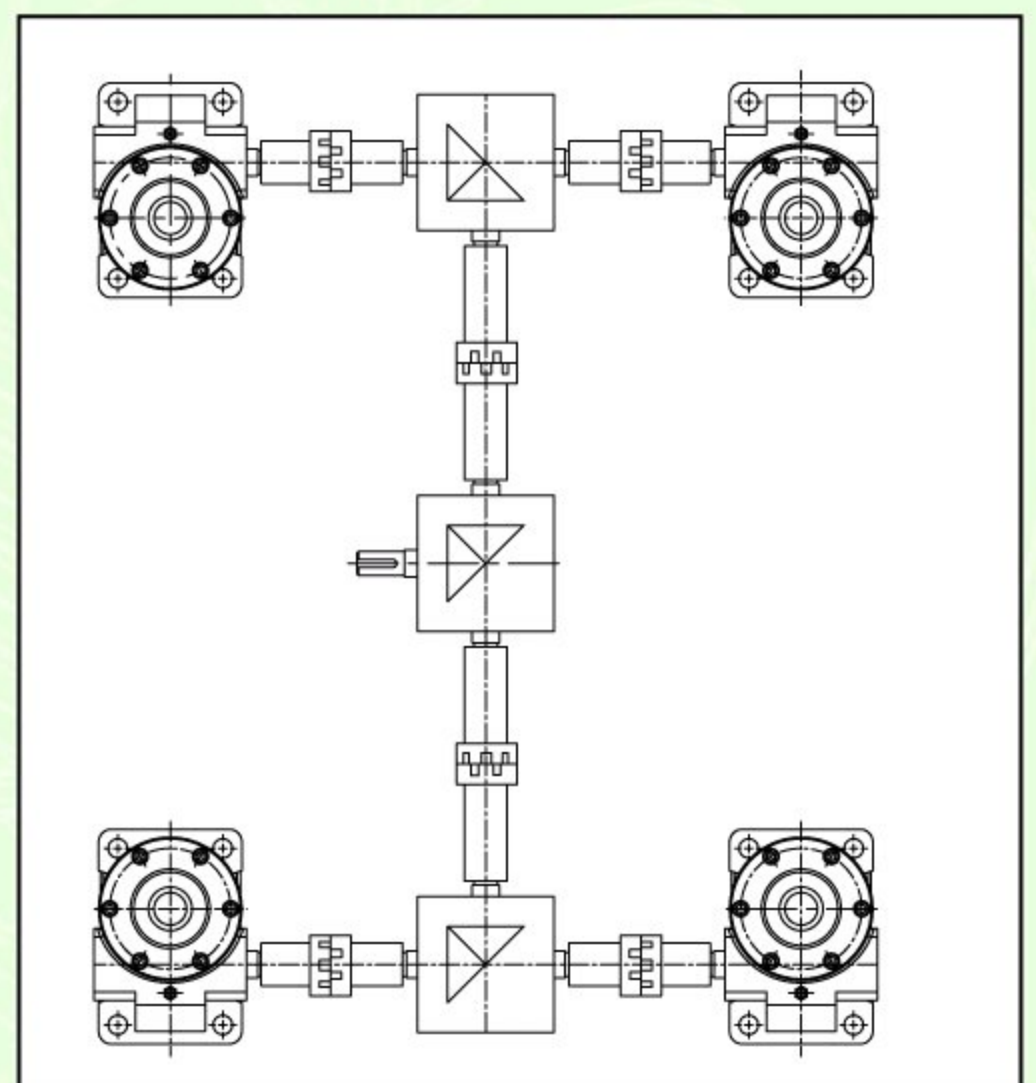

Basic Structure and Shaft Direction

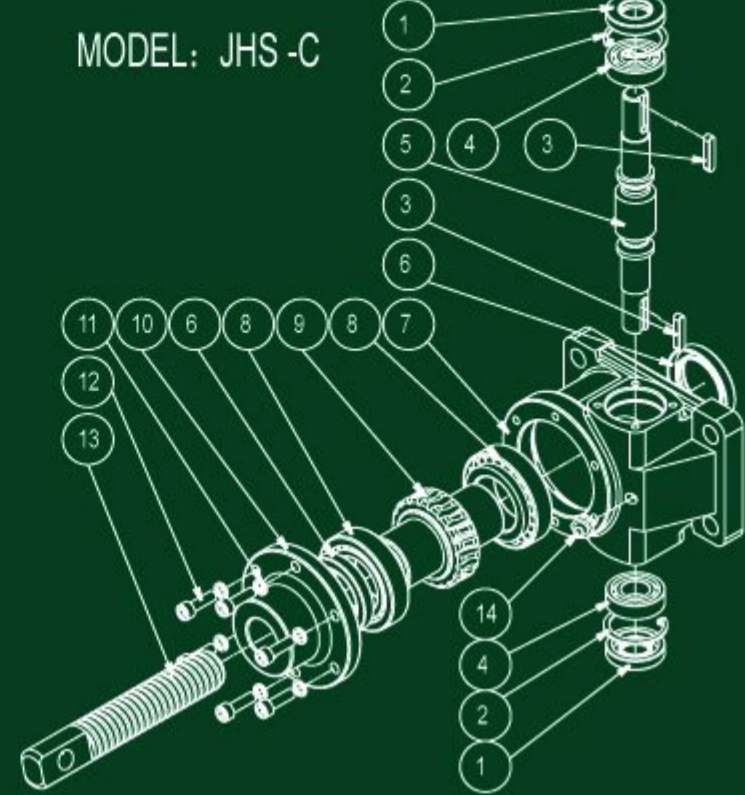
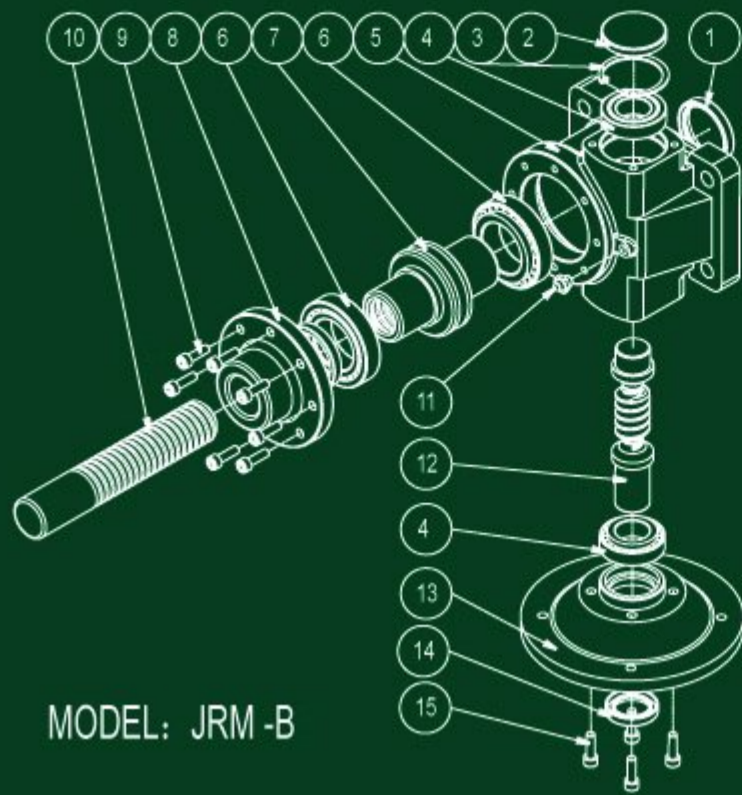

ITEM	PART NAME	QTY	ITEM	PART NAME	QTY	ITEM	PART NAME	QTY	ITEM	PART NAME	QTY	ITEM	PART NAME	QTY	ITEM	PART NAME	QTY
1	oil seal	1	6	bearing	2	11	fitting	1	1	oil seal	2	6	oil seal	2	11	spring	6
2	oil seal	1	7	worm wheel	1	12	worm shaft	1	2	oil seal	2	7	housing	1	12	screw	6
3	snap ring	1	8	cover	1	13	flange	1	3	key	2	8	bearing	2	13	end shaft	1
4	bearing	2	9	screw	8	14	oil seal	1	4	bearing	2	9	worm wheel	1	14	fitting	1
5	housing	1	10	end shaft	1	15	screw	4	5	worm shaft	1	10	cover	1			

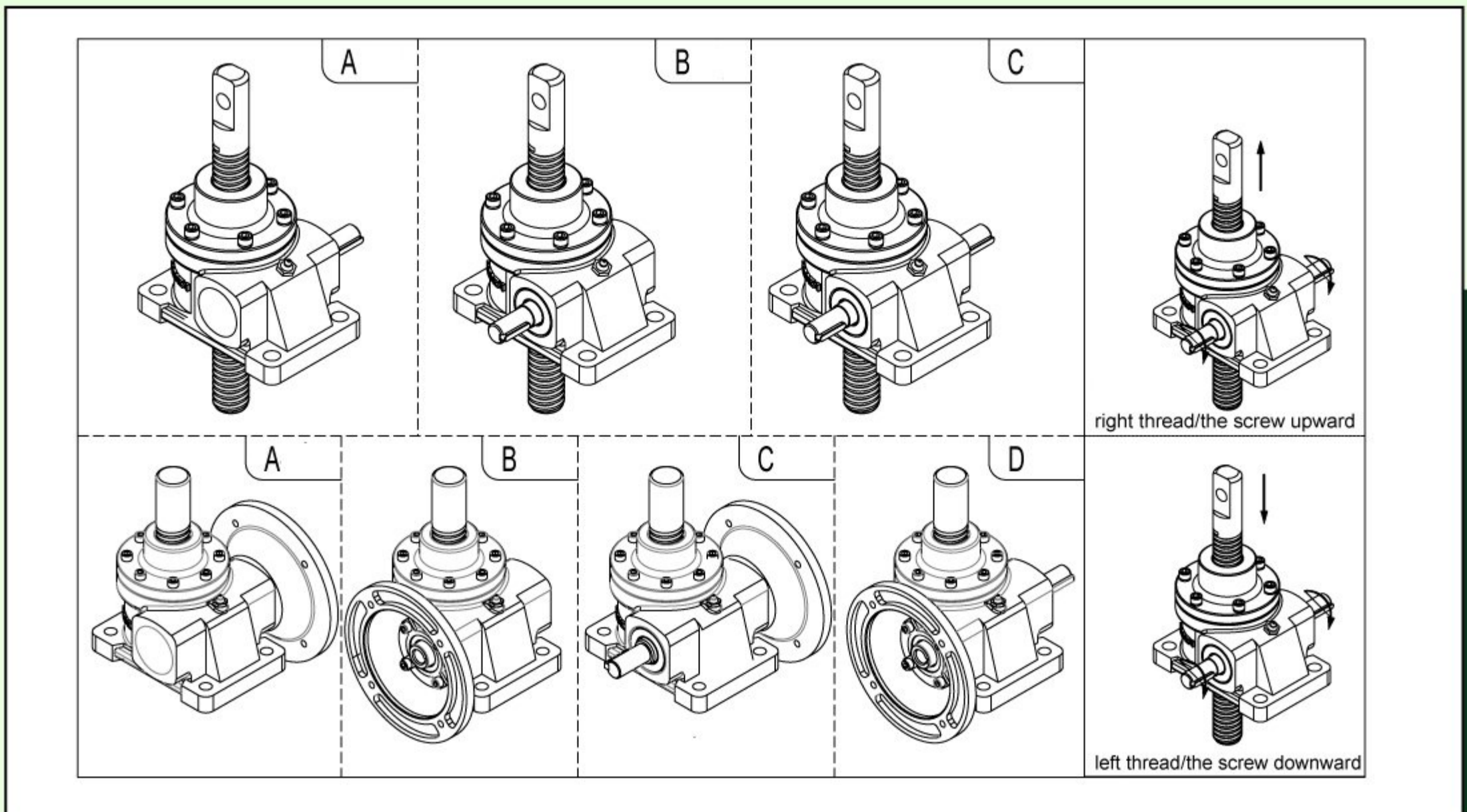



Dimensions (all Dimensions are in mm)

Size	Diameter	Pitch	Ratio			Transmission Efficiency		
35	Ø 1"	P=5	1/5	1/10	1/20	20%	18%	11%

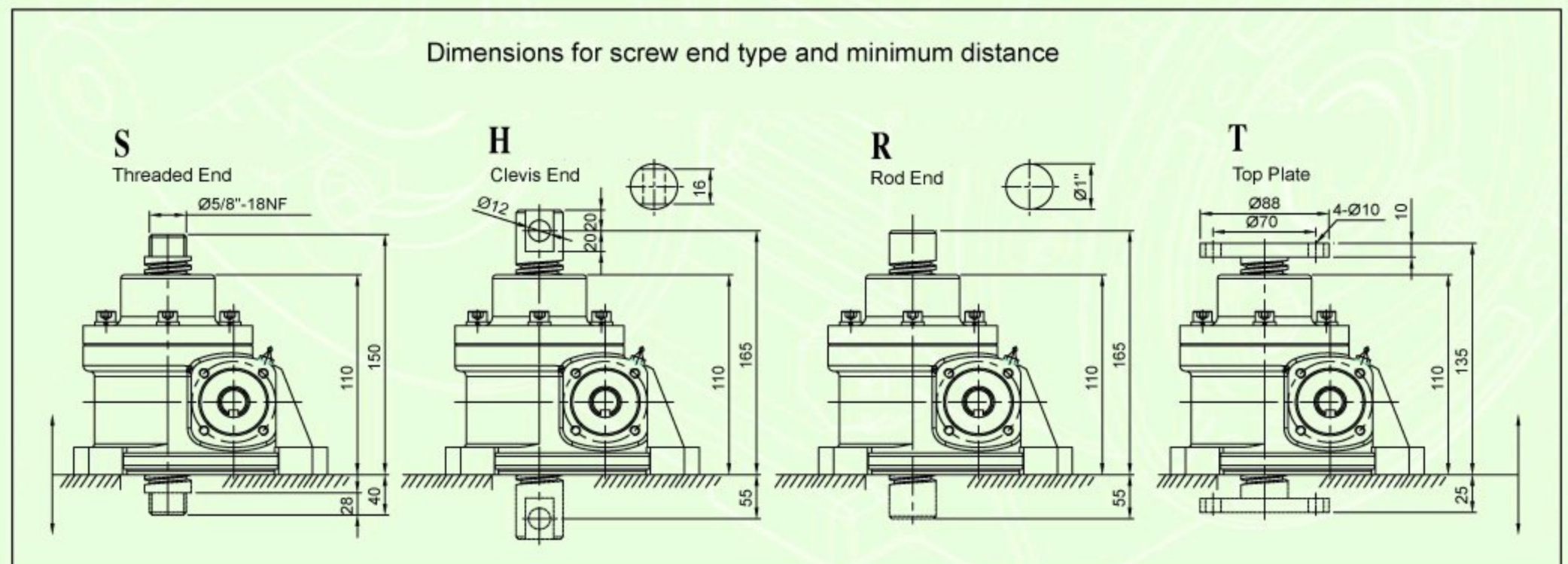
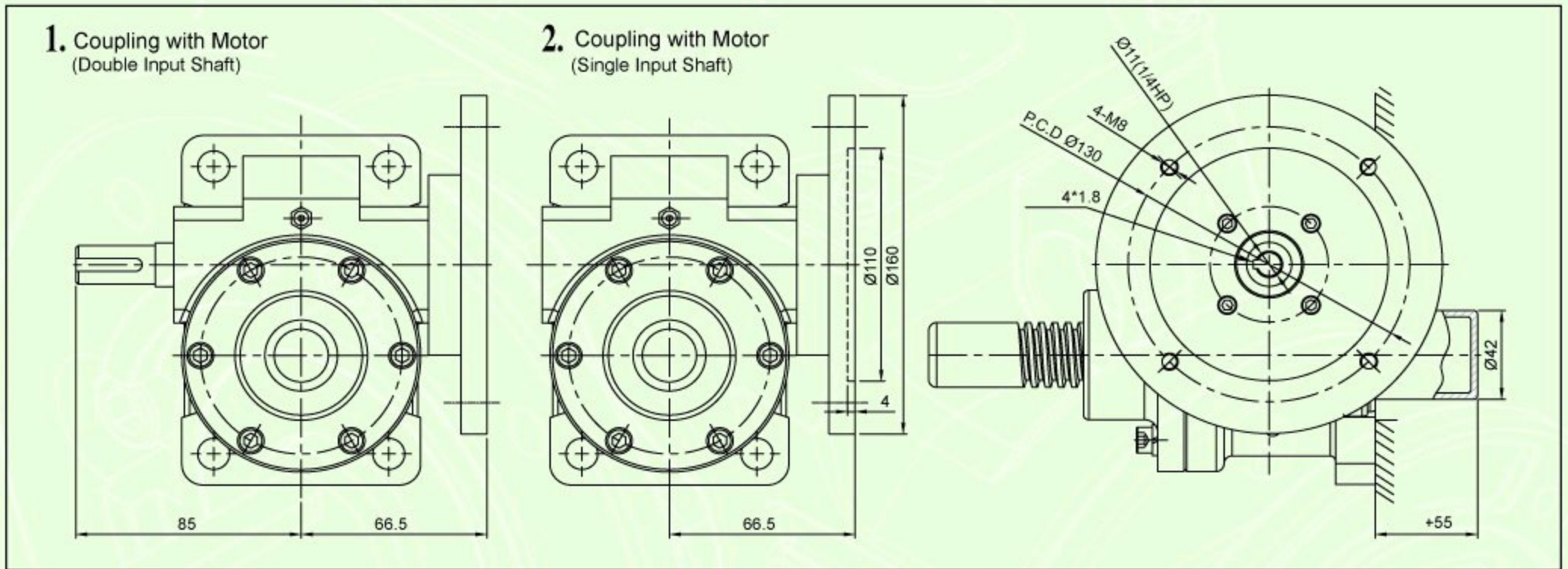
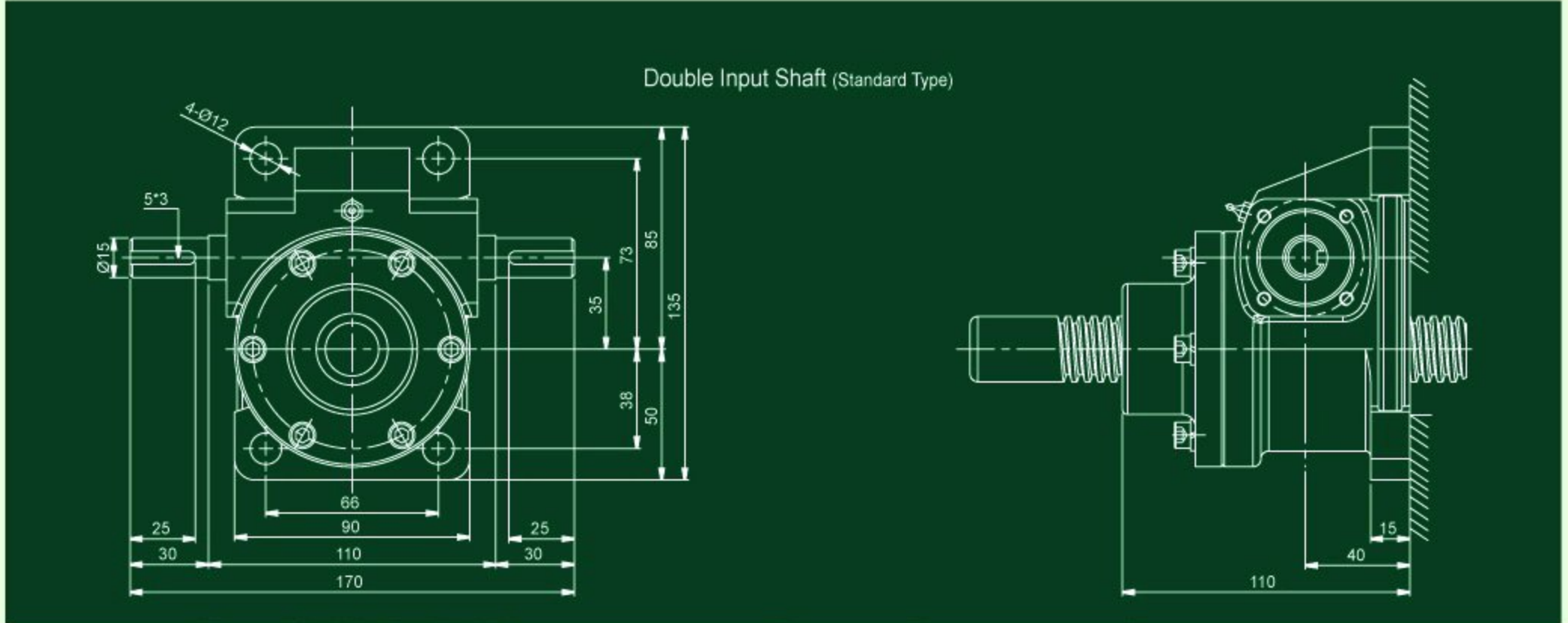

Dimensions (all Dimensions are in mm)



Size	Diameter	Pitch	Ratio			Transmission Efficiency		
40	Ø 1-1/4"	P=6	1/6	1/12	1/24	21%	21%	17%

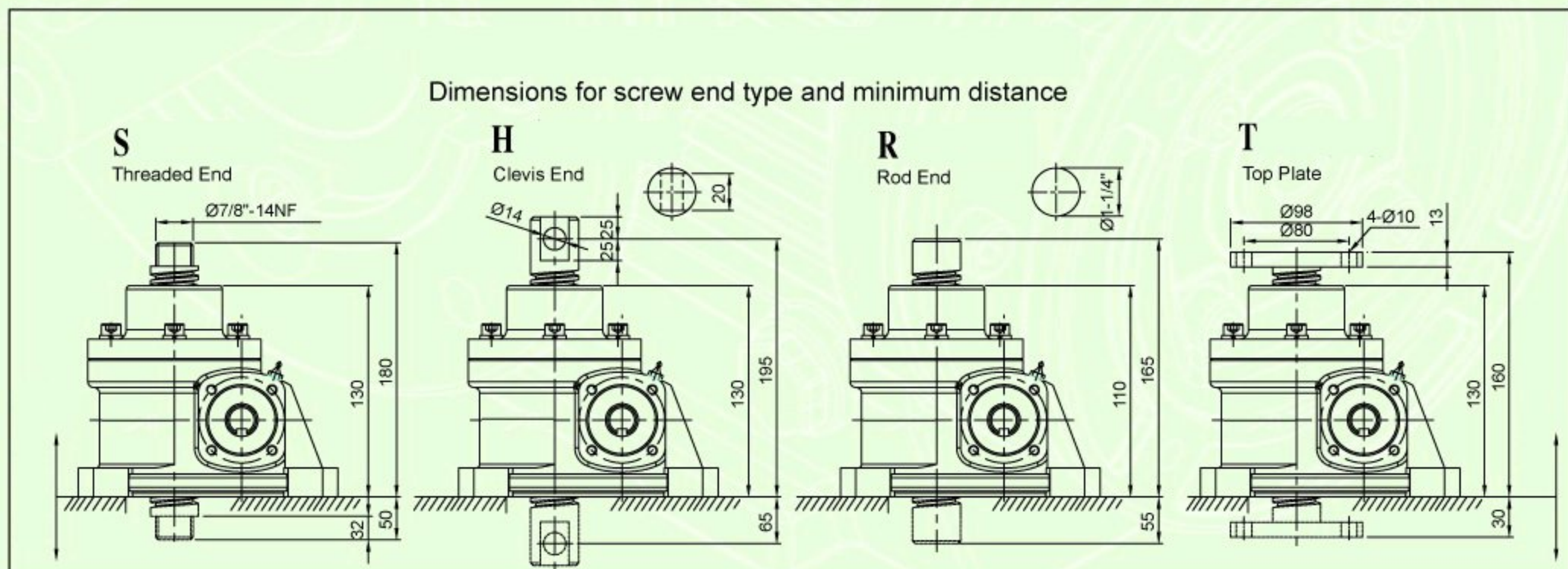
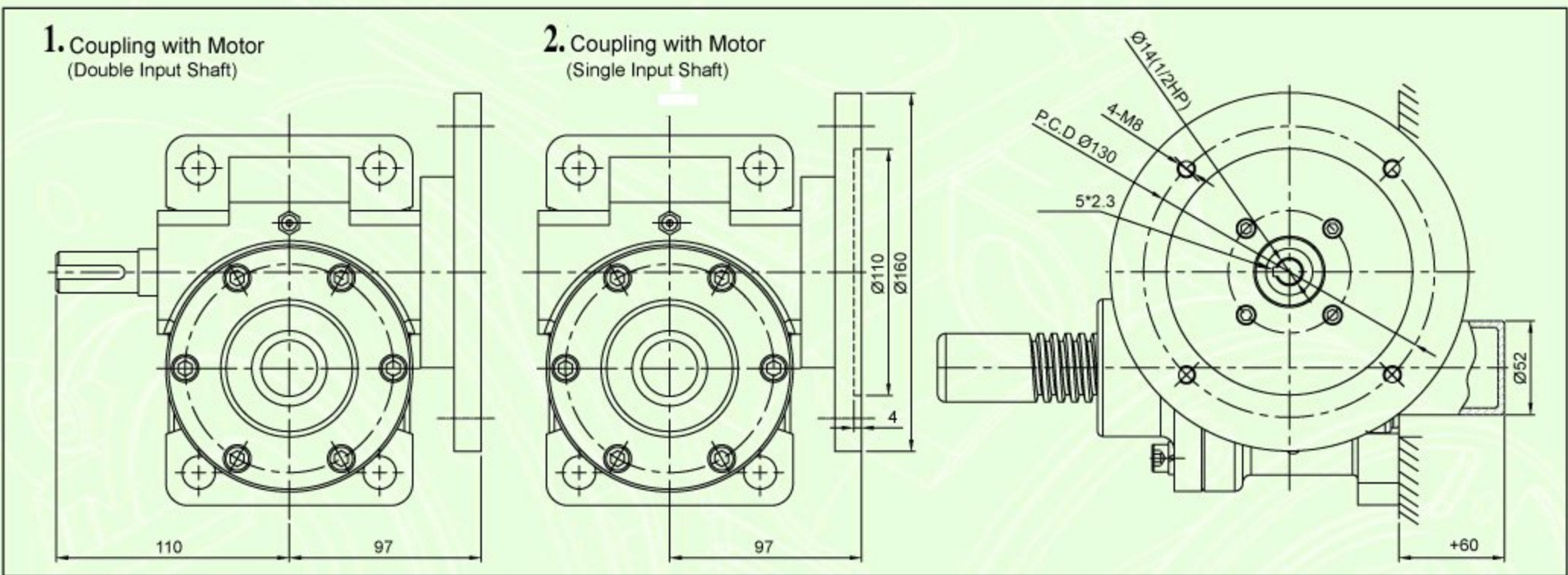
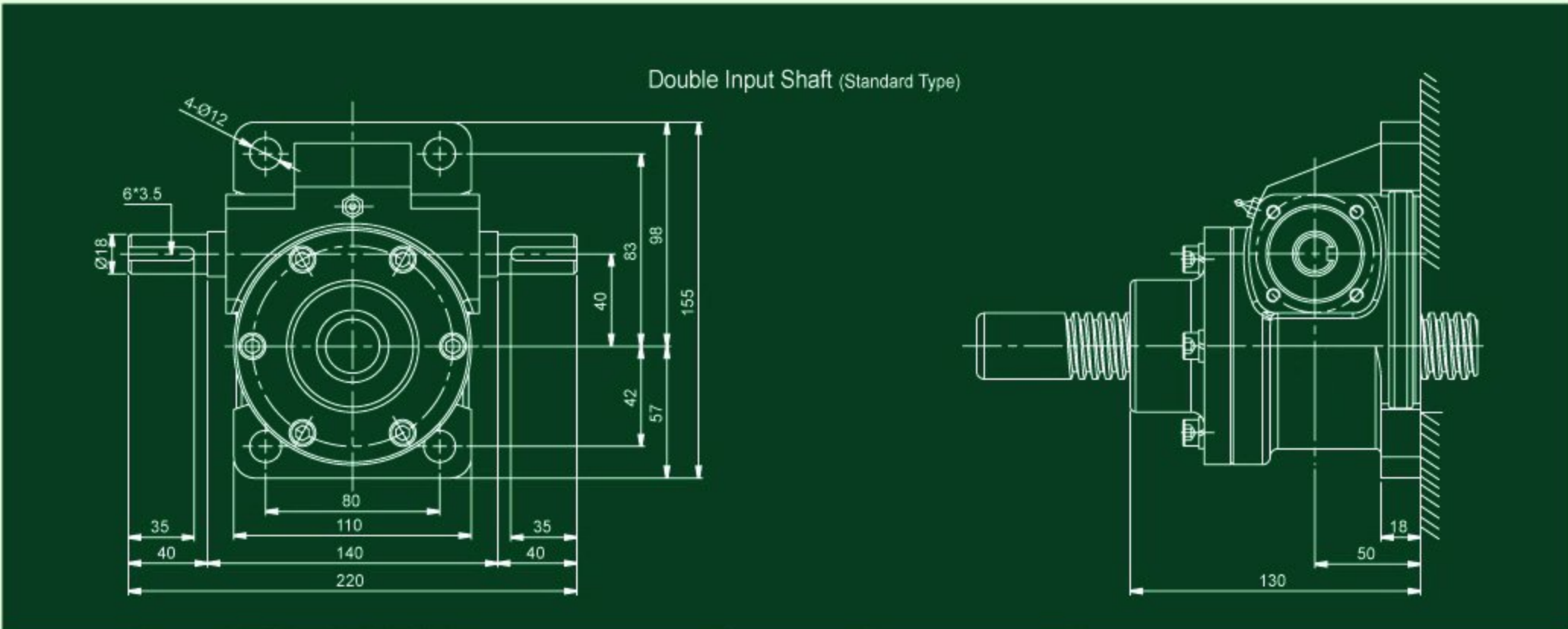



Dimensions (all Dimensions are in mm)

Size	Diameter	Pitch	Ratio			Transmission Efficiency		
50	Ø 1-1/2"	P=6	1/6	1/12	1/24	19%	18%	17%

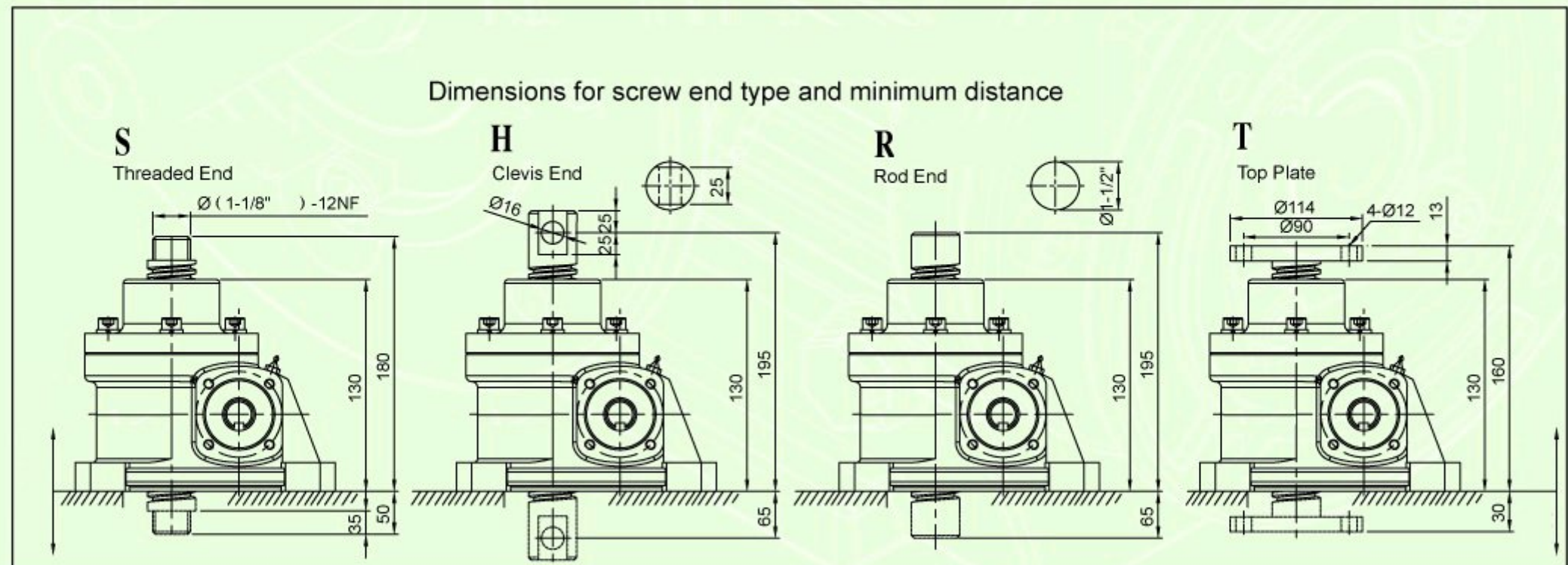
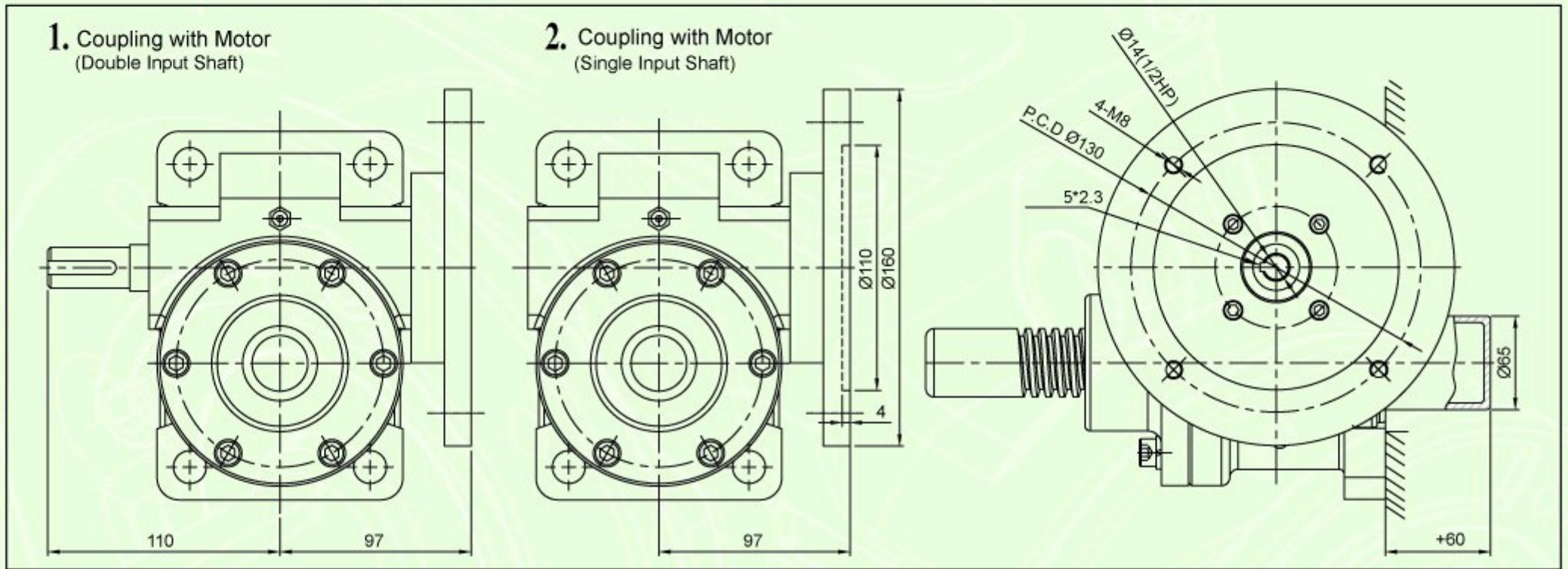
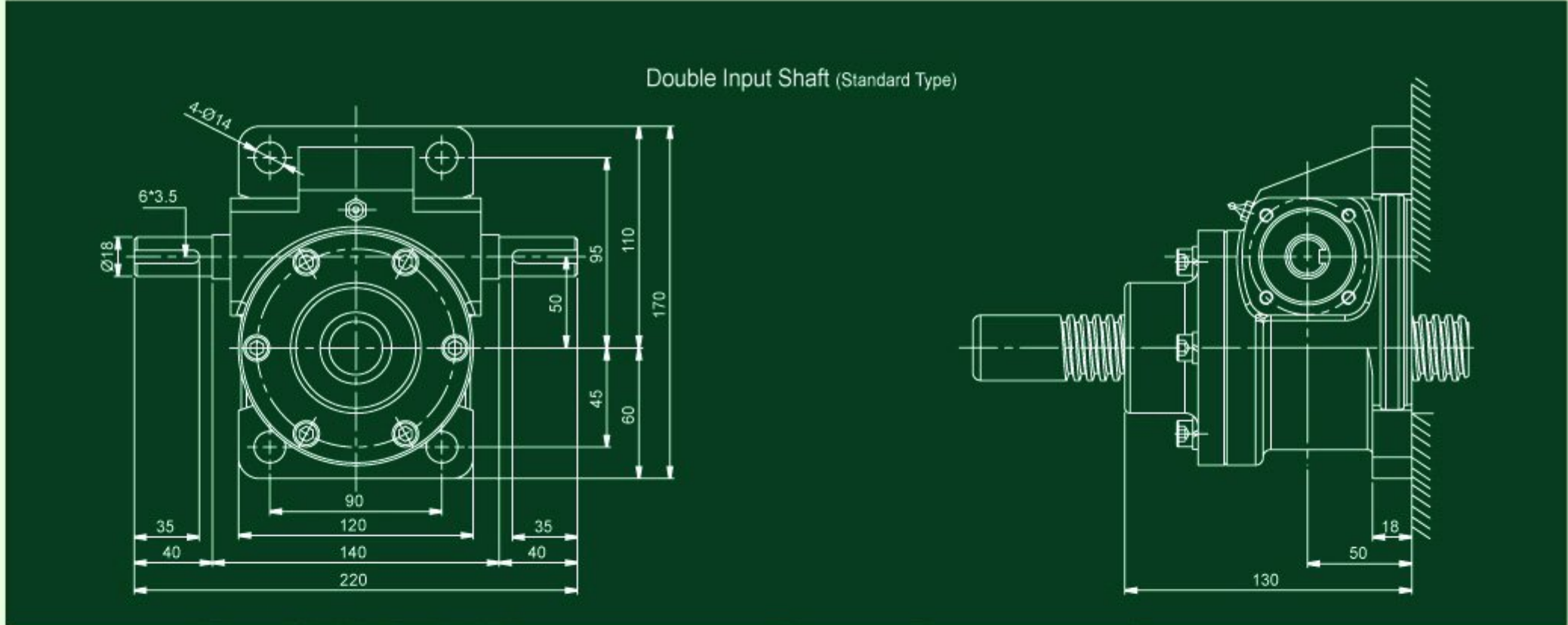

Dimensions (all Dimensions are in mm)



Size	Diameter	Pitch	Ratio			Transmission Efficiency		
60	Ø 1-3/4"	P=8	1/8	1/16	1/32	18%	17%	16%

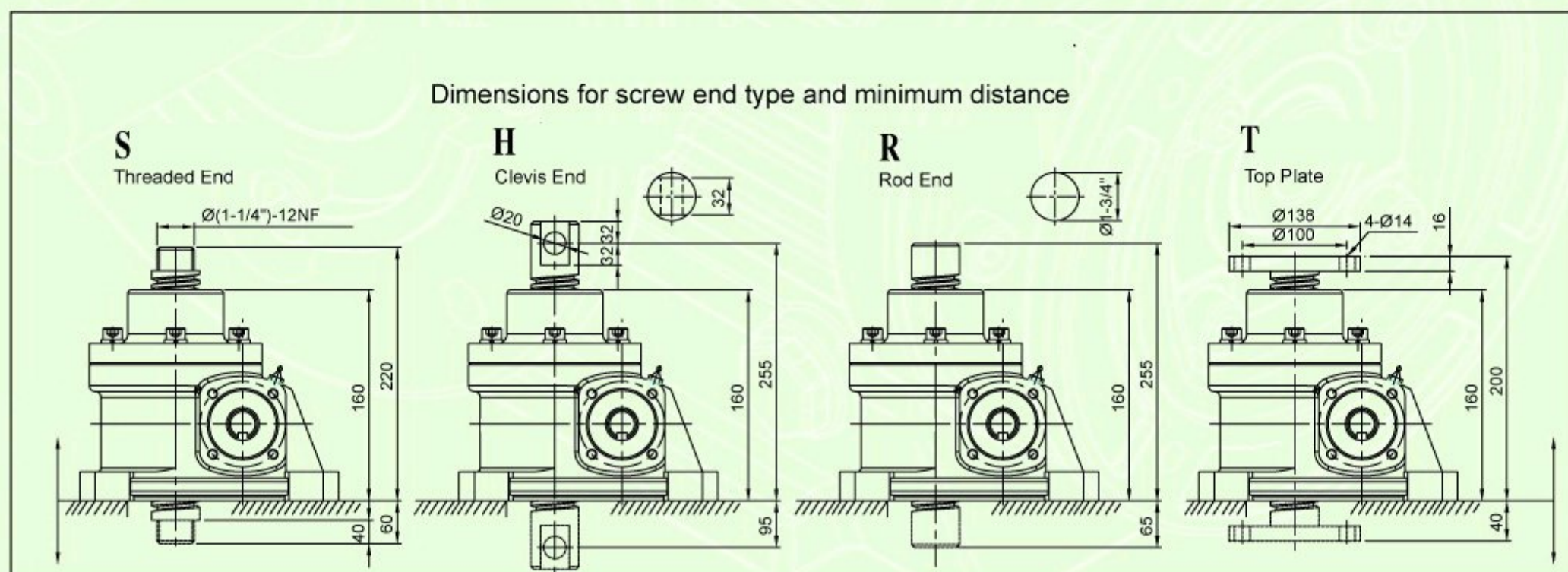
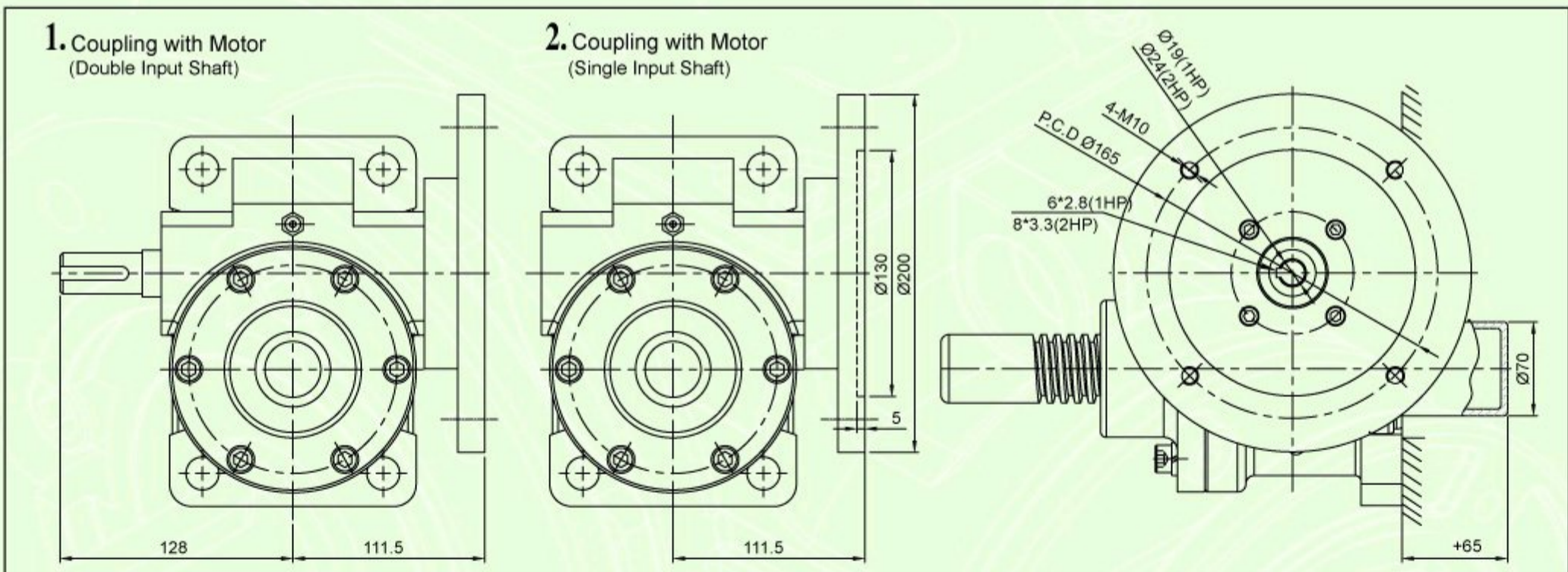
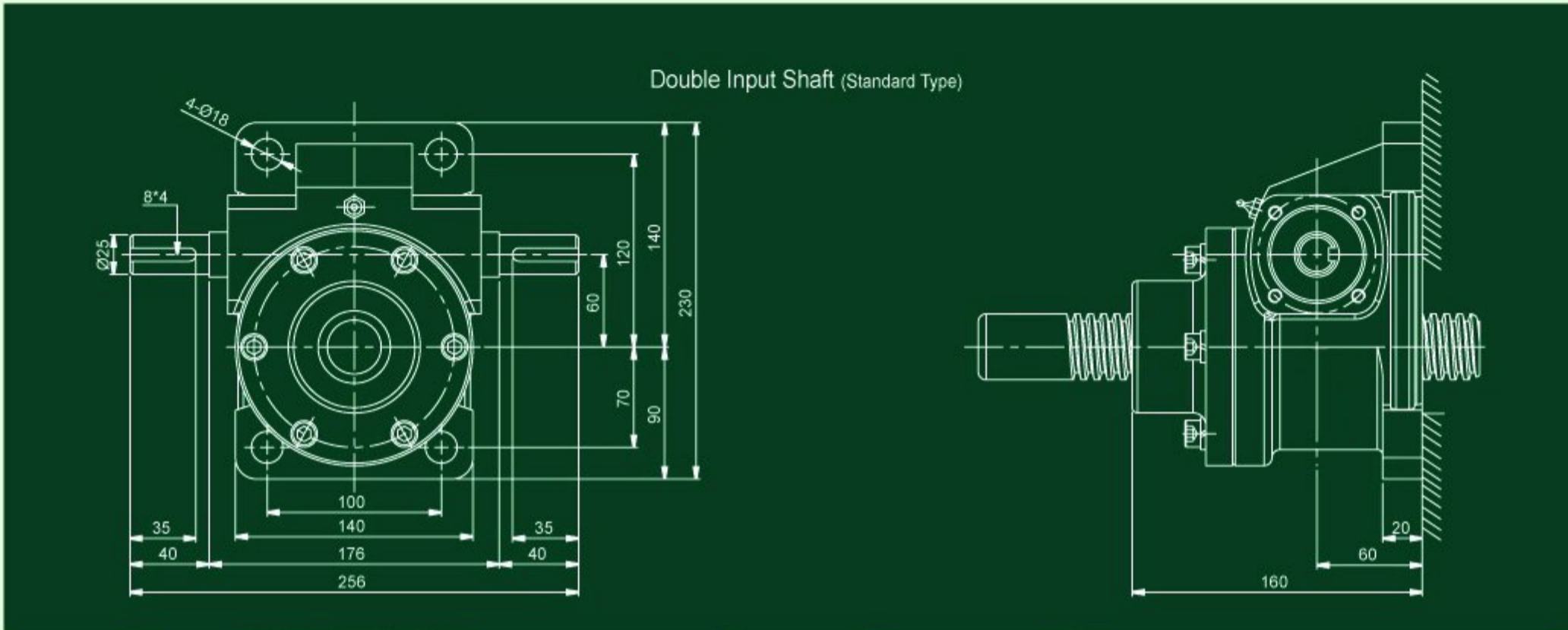



Dimensions (all Dimensions are in mm)

Size	Diameter	Pitch	Ratio			Transmission Efficiency		
65	Ø 2"	P=8	1/8	1/16	1/32	19%	18%	17%

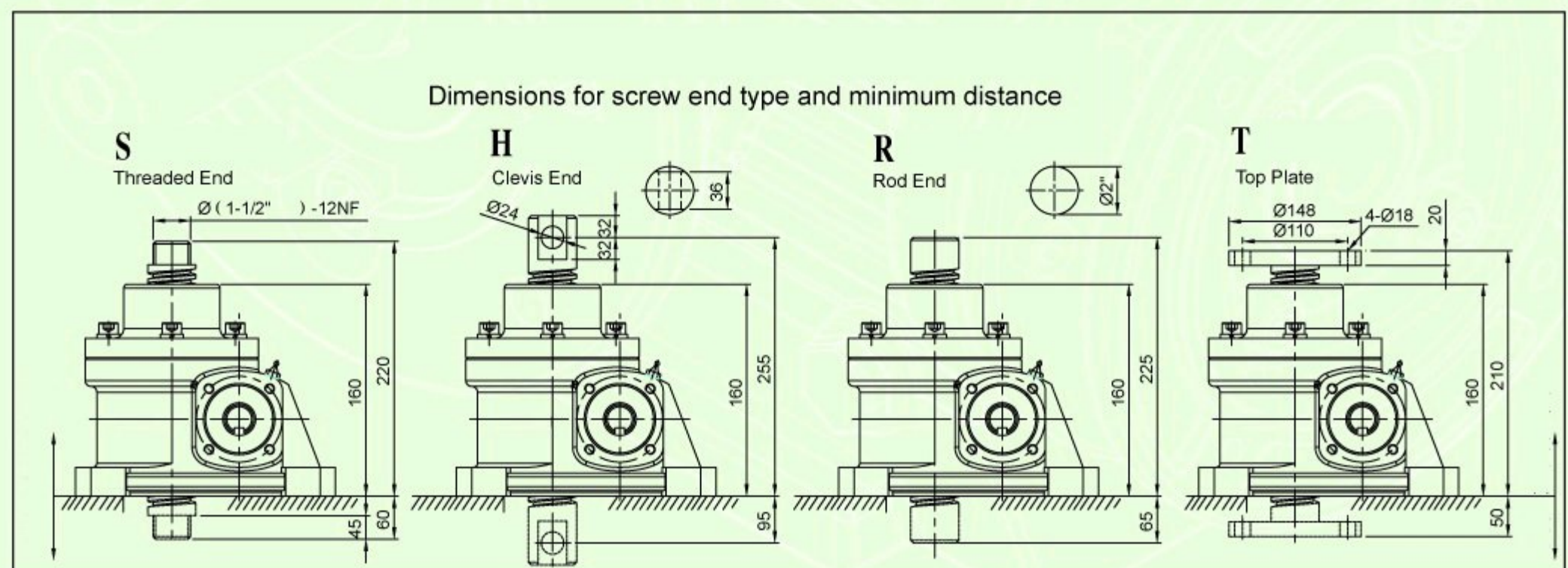
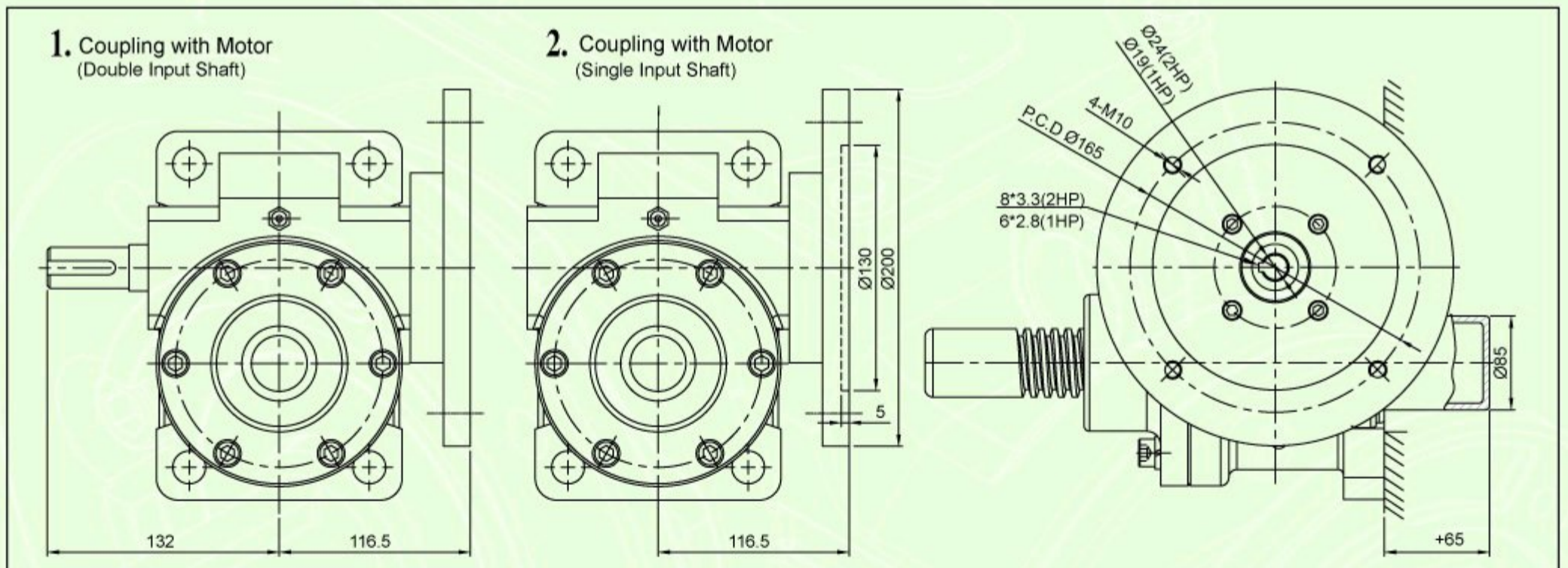
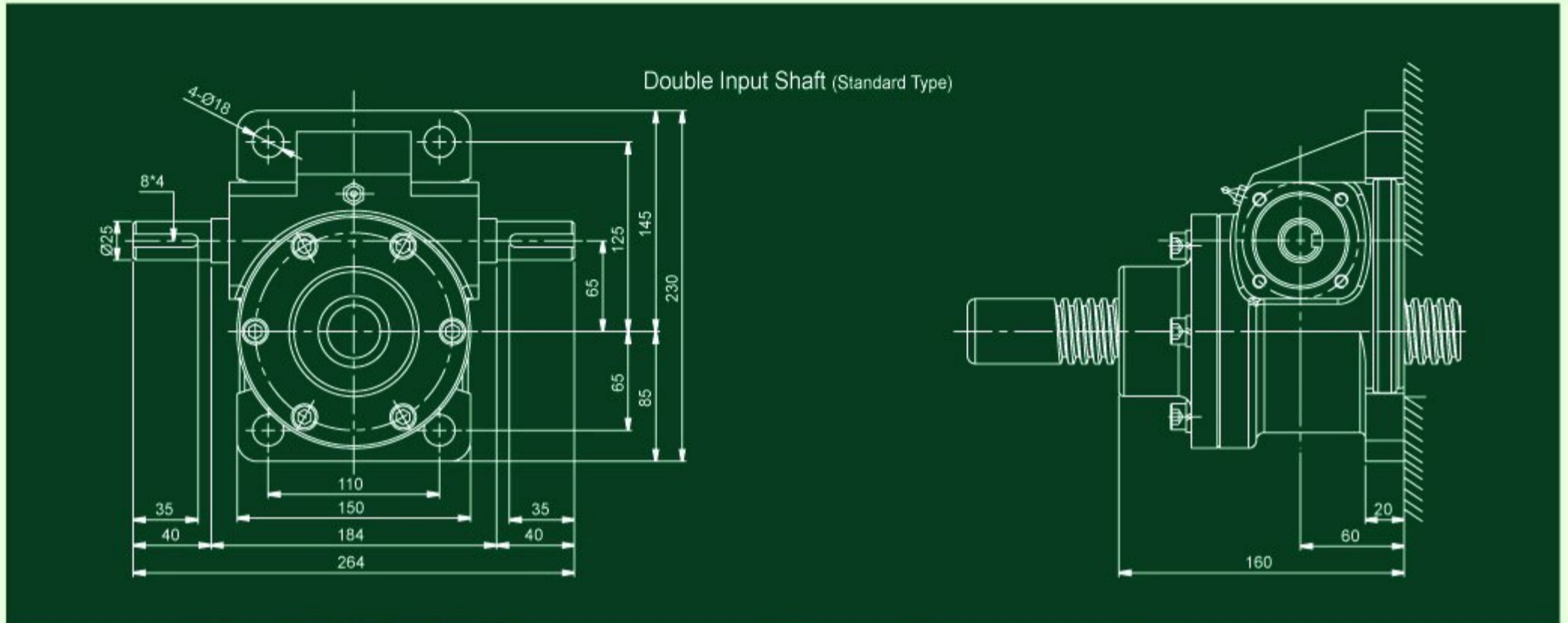

Dimensions (all Dimensions are in mm)



Size	Diameter	Pitch	Ratio			Transmission Efficiency		
70	Ø 2-1/2"	P=10	1/10	1/20	1/40	15%	15%	15%

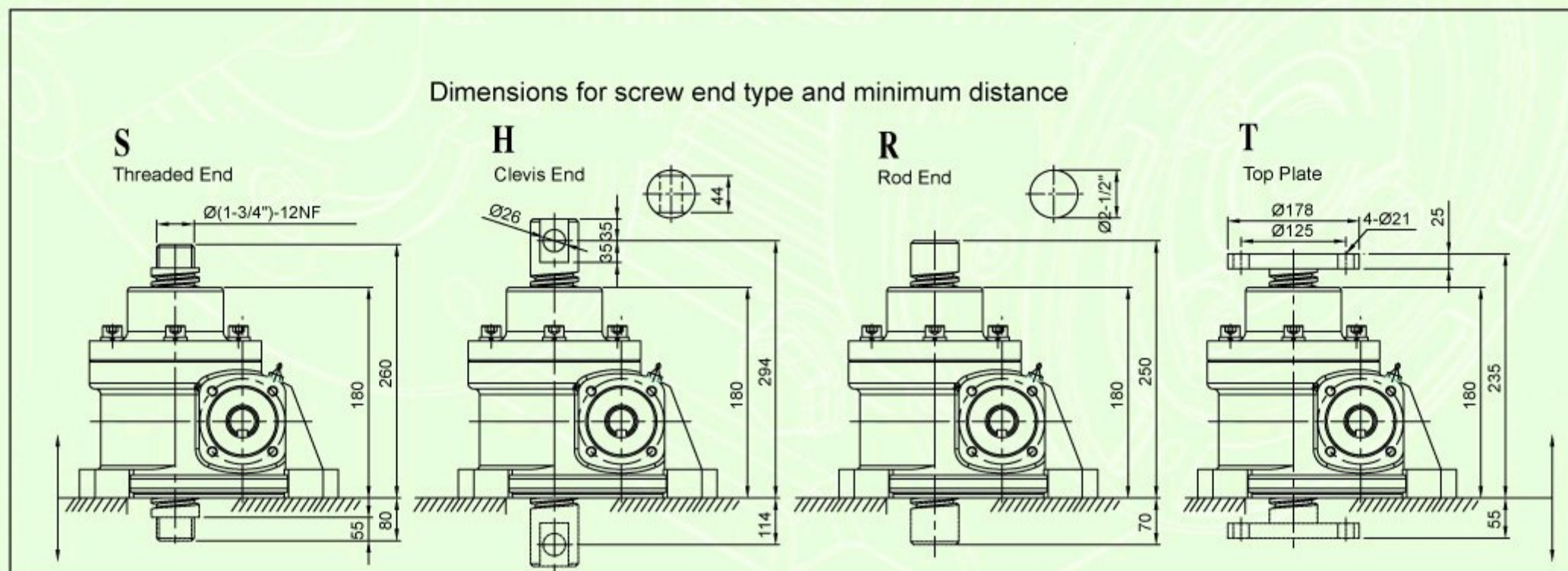
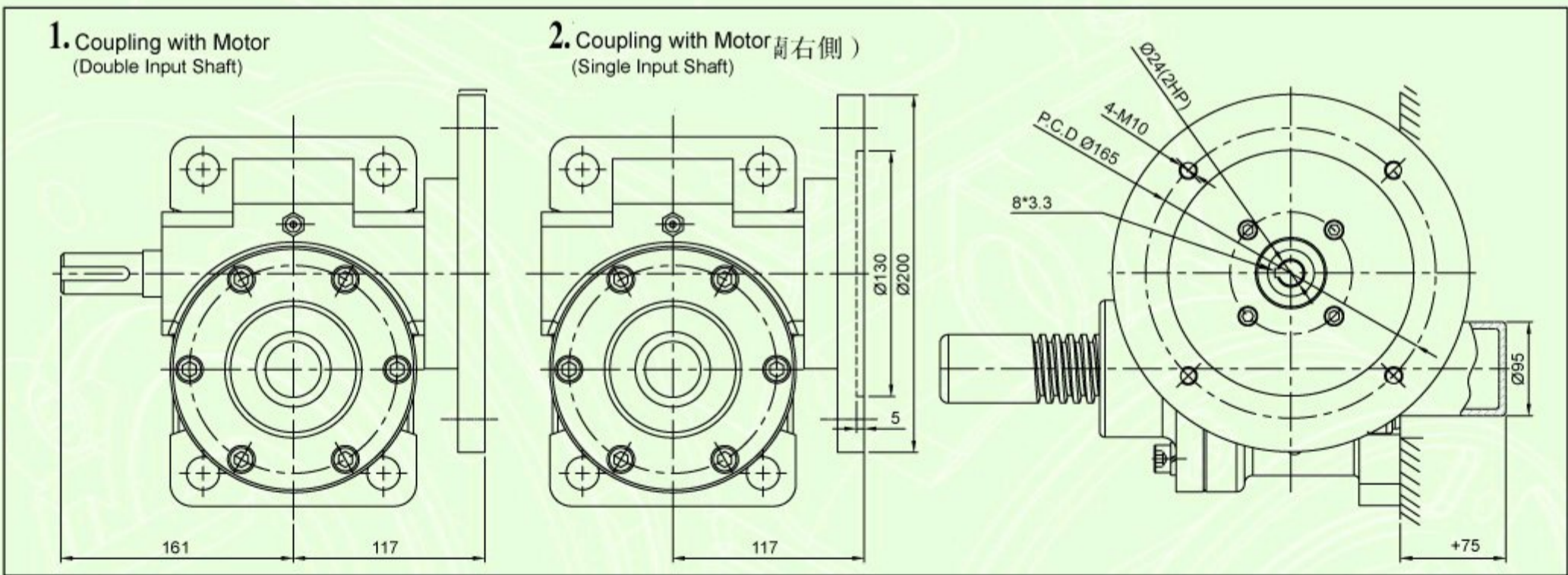
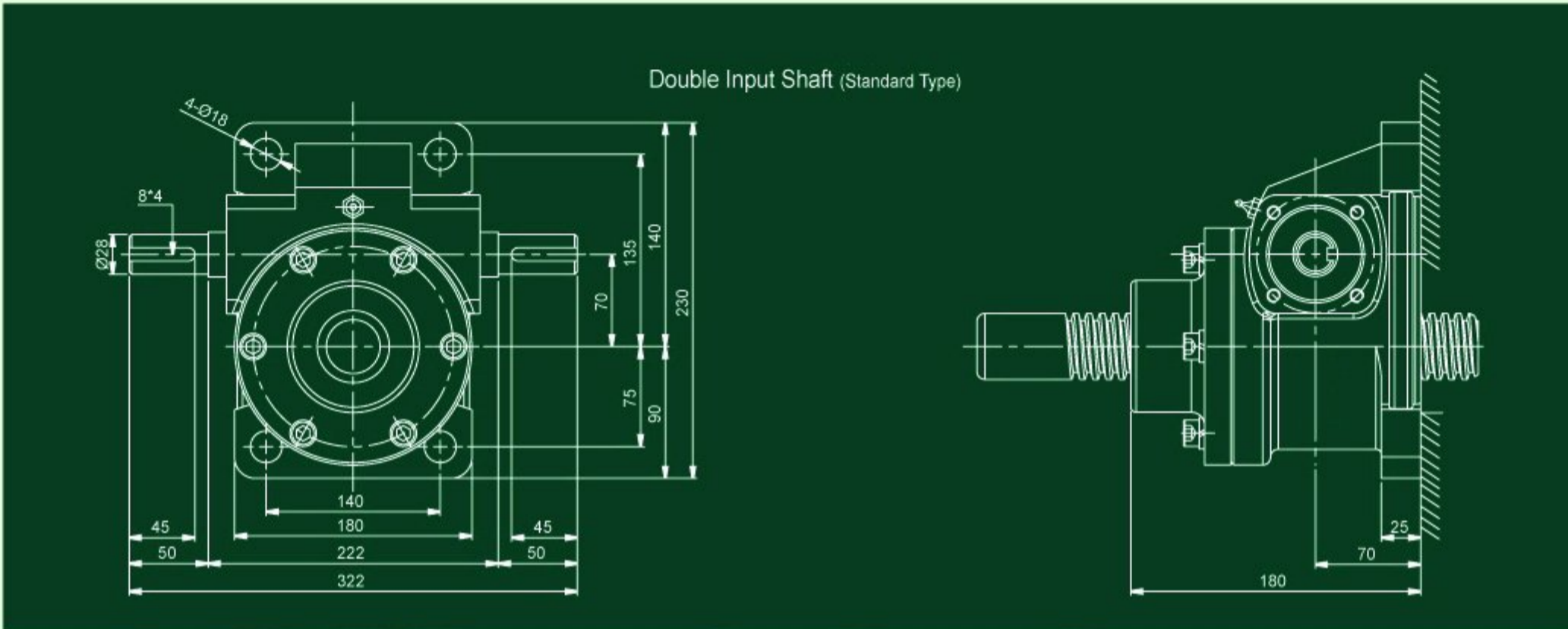



Dimensions (all Dimensions are in mm)

Size	Diameter	Pitch	Ratio			Transmission Efficiency		
100	Ø 75m/m	P=12	1/12	1/18	1/36	15%	14%	13%

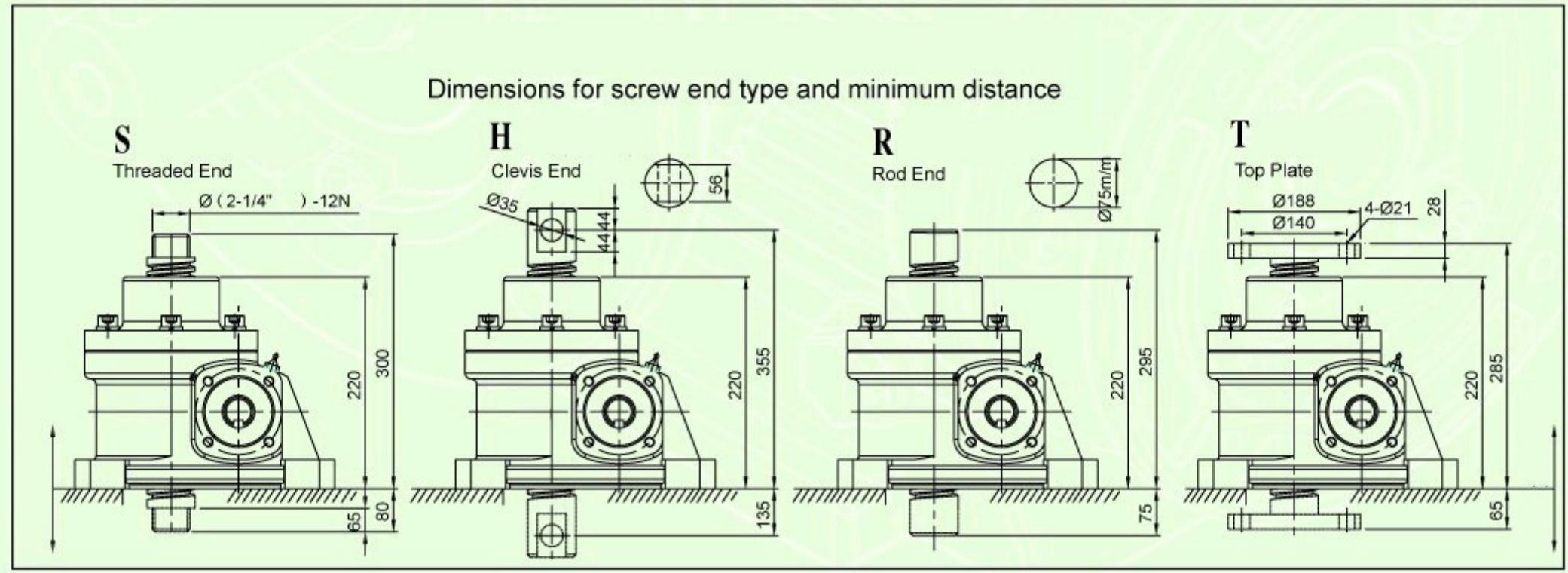
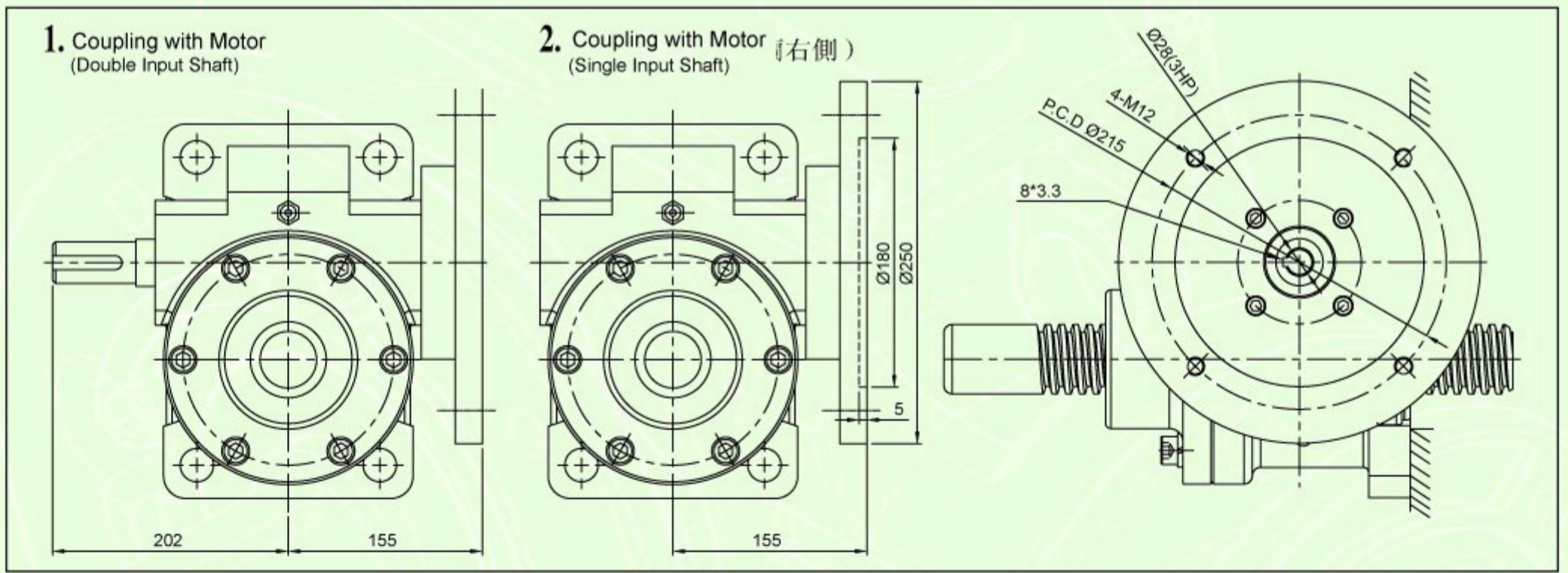
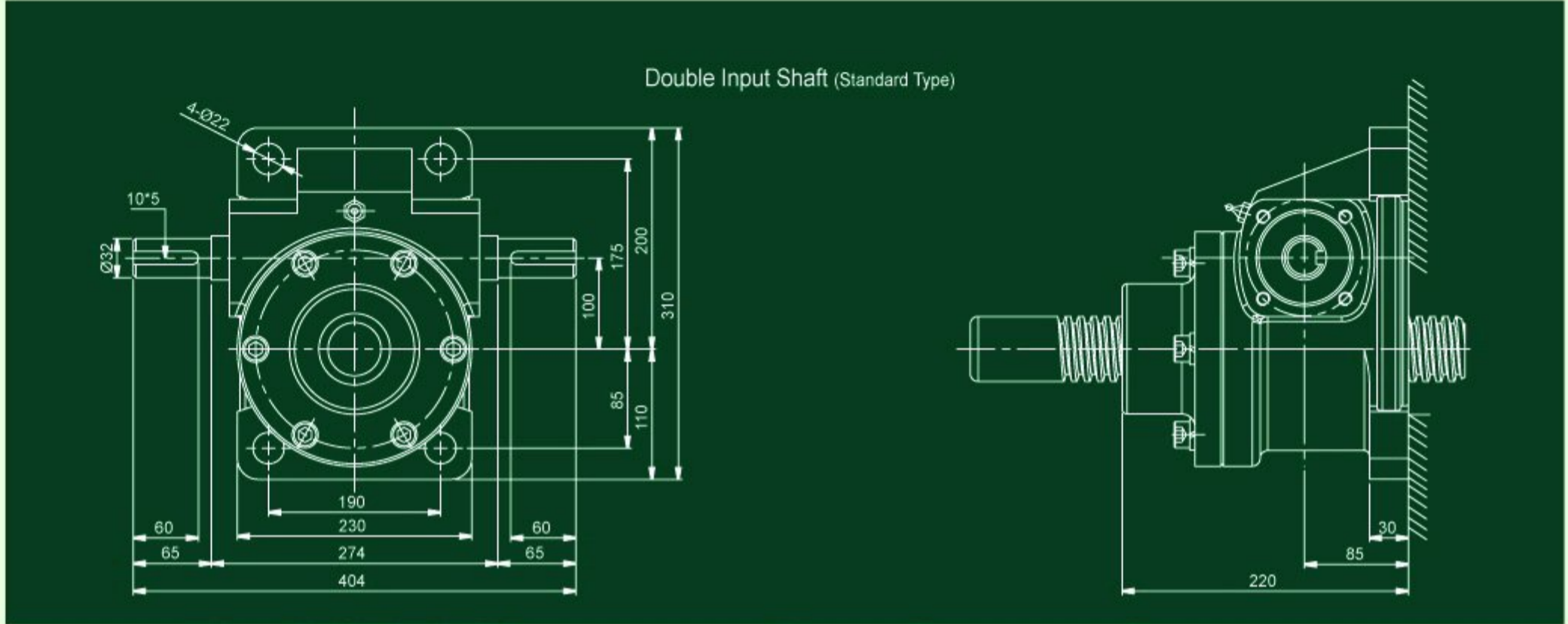

Calculation of End Screw Length



End Condition

S

Threaded End

H

Clevis End

R

Rod End

T

Top Plate

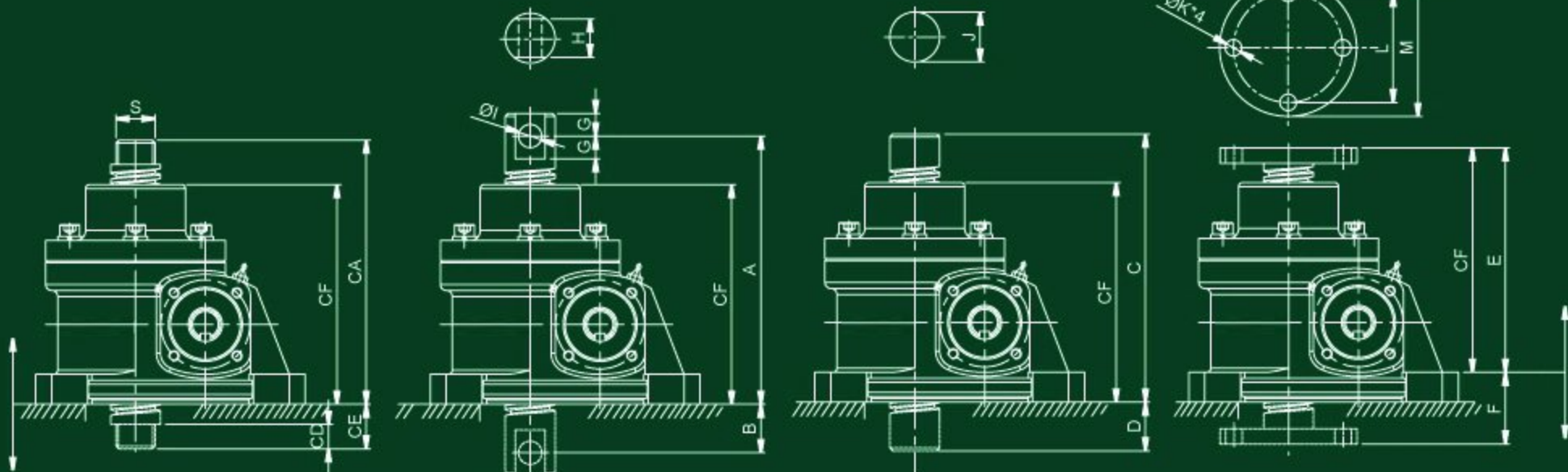

Vertical type
Horizontal type

Model	CA	CD	CE	CF	S	A	B	C	D	E	F	G	H	I	J	K	L	M	N
35	150	28	40	110	5/8"-18NF	165	55	165	55	135	25	20	16	12	1"	10	70	88	10
40	180	32	50	130	7/8"-14NF	195	65	195	65	160	30	25	20	14	1 1/4"	10	80	98	13
50	180	35	50	130	1 1/8"-12NF	195	65	195	65	160	30	25	25	16	1 1/2"	12	90	114	13
60	220	40	60	160	1 1/4"-12NF	255	95	225	65	200	40	32	32	20	1 3/4"	14	100	138	16
65	220	45	60	160	1 1/2"-12NF	255	95	225	65	210	50	32	36	24	2"	18	110	148	20
70	260	55	80	180	1 3/4"-12N	294	114	250	70	235	55	35	44	26	2 1/2"	21	125	178	25
100	300	65	80	220	2 1/4"-12N	355	135	295	75	285	65	44	56	35	75m/m	21	140	188	28

Length of Screw

(Length of screw refers to 300m/m)

Model	Diameter	Pitch	Length of Screw (300m/m) Protective Sleeve Length	S Threaded End		H Clevis End		R Rod End		T Top Plate	
				End Shaft Length	Thread Length	End Shaft Length	Thread Length	End Shaft Length	Thread Length	End Shaft Length	Thread Length
35	1"	P=5	300+55=355	110+40+300=450	450-40=410	110+55+20+300=485	485-20-55=410	110+55+300=465	465-55=410	110+25+300=435	435-25=410
40	1 1/4"	P=6	300+60=360	130+50+300=480	480-50=430	130+65+25+300=520	520-65-25=430	130+65+300=495	495-65=430	130+30+300=460	460-30=430
50	1 1/2"	P=6	300+60=360	130+50+300=480	480-50=430	130+65+25+300=520	520-65-25=430	130+65+300=495	495-65=430	130+30+300=460	460-30=430
60	1 3/4"	P=8	300+65=365	160+60+300=520	520-60=460	160+95+32+300=587	587-95-32=460	160+65+300=525	525-65=460	160+40+300=500	500-40=460
65	2"	P=8	300+65=365	160+60+300=520	520-60=460	160+95+32+300=587	587-95-32=460	160+65+300=525	525-65=460	160+50+300=510	510-50=460
70	2 1/2"	P=10	300+75=375	180+80+300=560	560-80=480	180+114+35+300=629	629-114-35=480	180+70+300=550	550-70=480	180+55+300=535	535-55=480
100	75m/m	P=12		220+80+300=600	600-80=520	220+135+44+300=699	699-135-44=520	220+75+300=595	595-75=520	220+65+300=585	585-65=520

Remarks: Dimensions are subject to change without notice.



Rating Data

Model	Lifting screw	Ratio	1800 RPM			1500 RPM			1200 RPM			900 RPM			600 RPM			300 RPM		
			Input RPM			Input RPM			Input RPM			Input RPM			Input RPM			Input RPM		
			Input Power (KW)	Lifting Load (KG)	Lifting Speed (mm/min)	Input Power (KW)	Lifting Load (KG)	Lifting Speed (mm/min)	Input Power (KW)	Lifting Load (KG)	Lifting Speed (mm/min)	Input Power (KW)	Lifting Load (KG)	Lifting Speed (mm/min)	Input Power (KW)	Lifting Load (KG)	Lifting Speed (mm/min)	Input Power (KW)	Lifting Load (KG)	Lifting Speed (mm/min)
35	Ø1"	1/5	0.70	500	1800	0.65	550	1500	0.65	700	1200	0.63	900	900	0.47	1000	600	0.38	1000	300
	ACME	1/10	0.38	500	900	0.38	550	750	0.38	700	600	0.38	750	450	0.38	1000	300	0.19	1350	150
	P=5	1/20	0.38	600	450	0.38	700	375	0.38	900	300	0.38	1200	225	0.19	1350	150	0.19	1350	75
40	Ø1 1/4"	1/6	0.98	700	1800	0.94	800	1500	0.89	950	1200	0.92	1300	900	0.84	1800	600	0.42	1800	300
	ACME	1/12	0.67	950	900	0.65	1100	750	0.61	1300	600	0.58	1650	450	0.47	2000	300	0.38	2000	150
	P=6	1/24	0.38	450	450	0.38	1100	375	0.38	1300	300	0.38	1650	225	0.38	2000	150	0.19	2000	75
50	Ø1 1/2"	1/6	1.40	900	1800	1.29	1000	1500	1.25	1200	1200	1.16	1500	900	0.88	1700	600	0.54	2100	300
	ACME	1/12	1.10	1350	900	1.02	1500	750	0.98	1800	600	0.88	2150	450	0.59	2150	300	0.38	2500	150
	P=6	1/24	0.78	1800	450	0.72	2000	375	0.69	2400	300	0.55	2550	225	0.42	2900	150	0.38	2850	75
60	Ø1 3/4"	1/8	2.13	1300	1800	1.98	1450	1500	1.86	1700	1200	1.73	2100	900	1.67	3050	600	1.31	4800	300
	ACME	1/16	1.13	1300	900	1.05	1450	750	0.98	1700	600	0.95	2200	450	0.88	3050	300	0.69	4800	150
	P=8	1/32	0.80	1750	450	0.75	1950	375	0.69	2250	300	0.65	2800	225	0.63	4100	150	0.49	6400	75
65	Ø2"	1/8	2.02	1300	1800	1.88	1450	1500	1.76	1700	1200	1.63	2100	900	1.58	3050	600	1.25	4800	300
	ACME	1/16	1.07	1300	900	0.99	1450	750	0.93	1700	600	0.90	2200	450	0.83	3050	300	0.65	4800	150
	P=8	1/32	0.76	1750	450	0.71	1950	375	0.65	2250	300	0.61	2800	225	0.59	4100	150	0.46	6400	75
70	Ø2 1/2"	1/10	2.68	1400	1800	2.43	1850	1500	2.26	1950	1200	2.13	2450	900	1.94	3350	600	1.42	4900	300
	ACME	1/20	1.43	1600	900	1.48	1850	750	1.38	2250	600	1.29	2800	450	1.19	3850	300	0.86	5600	150
	P=10	1/40	1.15	2400	450	1.18	2800	375	1.10	3350	300	1.08	4400	225	0.94	5750	150	0.69	8400	75
100	Ø75m/m	1/12	3.65	1850	1800	3.53	2150	1500	3.41	2600	1200	3.20	3250	900	2.96	4500	600	2.10	6400	300
	ACME	1/18	2.67	1900	900	2.69	2300	750	2.58	2750	800	2.46	3500	600	2.21	4700	400	1.57	6700	200
	P=12	1/36	1.67	2200	450	1.64	2600	375	1.61	3200	400	1.48	3900	300	1.37	5400	200	1.21	9600	100

Parts of Screw Jack Reducer



Size of the Nut

Model	35	40	50	60	65	70	100
Lifting Screw Diameter	1"	1-1/4"	1-1/2"	1-3/4"	2"	2-1/2"	75m/m
Pitch	ACME P=5	ACME P=6	ACME P=6	ACME P=8	ACME P=8	ACME P=10	ACME P=5
Ratio	1/5 1/10 1/20	1/6 1/12 1/24	1/6 1/12 1/24	1/8 1/16 1/32	1/8 1/16 1/32	1/10 1/20 1/40	1/12 1/18 1/36

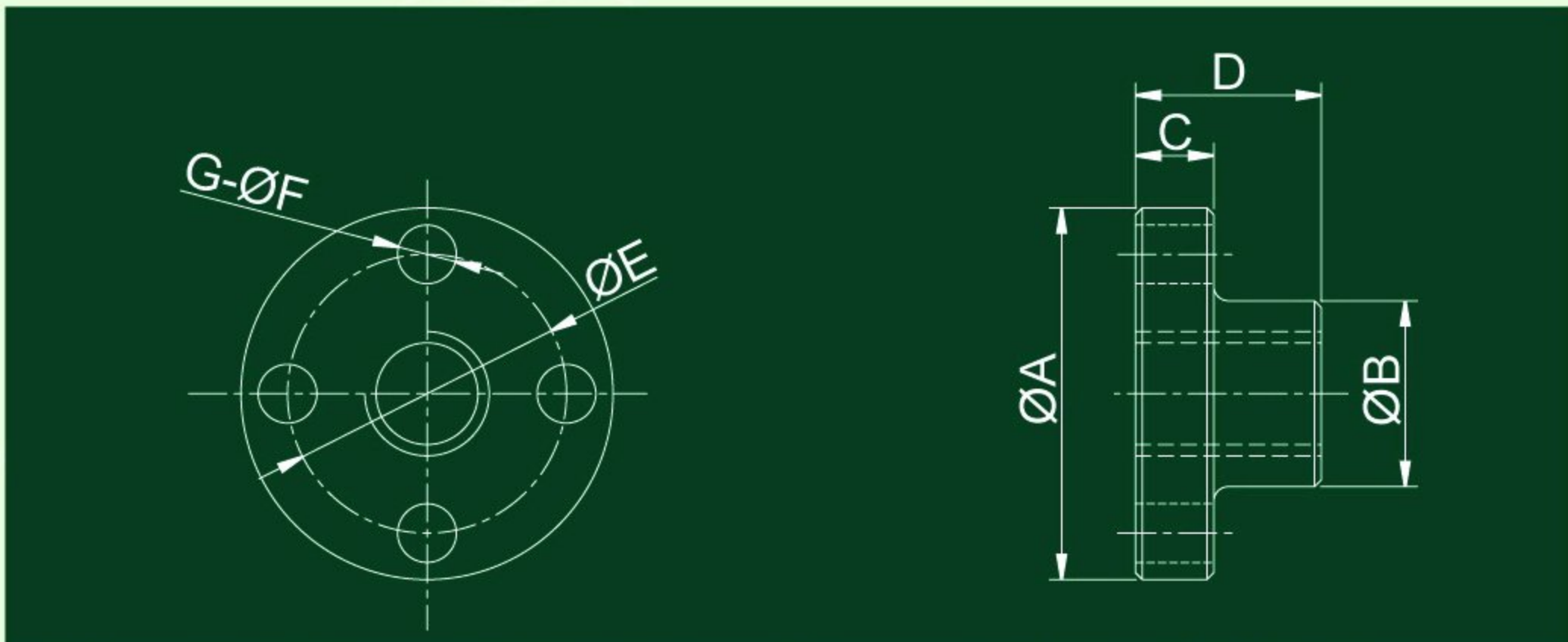

A	76	94	114	134	160	190	220
B	38	48	58	68	78	95	114
C	16	18	20	32	35	38	45
D	38	44	50	75	80	100	140
E	57	72	86	100	120	140	160
F	12	14	14	18	18	24	27
G	4	4	4	4	4	4	6

Screw Jack Reducer

I. INSTALLATION

1. Input shaft connects to motor directly, a flexible coupling prefer to apply according; output shaft connects to machine, it is better to use a gear coupling.
2. Install on a stable foundation and good air ventilation and the convenience of oil filling / draining should be considered.
3. The input shaft of the reducer and the motor shaft should be in alignment and the tolerance should fit the allowance.
4. After installation, please check input shaft by hand first to check whether running smoothly of nut.
5. Before start-up, no-load running test should be proceeded and any abnormal status occurred should be corrected immediately.

II. LUBRICATION

1. A new reducer needs replace oil in the beginning of 500 hrs operation; and then, each 2,500 hrs change again. Moreover, a regular oil checking is required and change necessarily.
2. Please change by equivalent specification of oil and don't mix with other brand of specification of oil.
3. Before changing oil, the inside of reducer should be flushed and drain out, then fill in new oil.
4. During operation, if the heat is over 80°C or any abnormal noise occurred, please shut down the reducer for checking immediately and start running only after the cause is resolved.
5. Lubricant recommendation: MOBIL gear 632, SHELL omala 320 or MOBIL mobilube HD80W-90, SHELL spirax E.P. 90.