

The Elastomeric Tensioners employ a time proven design, to ensure that both chain and belt drives run under a consistent and uniform tension negating chain and belt stretch.

The Elastomeric Tensioner's benefits include:

- A one nut mounting system, which allows for 360° rotation.
- Can be pre-tensioned by up to 30°, this means that as the chain or belt stretches, the tensioner automatically takes up the slack as the elastomeric elements automatically adjust the drives tension.
- Chain and Belt life is increased by as much as 30%.
- Elastomeric parts absorb vibrations and shock loading.
- Maintenance Free – no metal on metal parts, lubrication free.
- Impervious to dust and dirt, temperature -40° to +80°
- Two holes are provided on the arm, allowing two different levels of force to be generated: 'normal' and 'hard'. The 'hard' setting deploys approximately 25% more force.

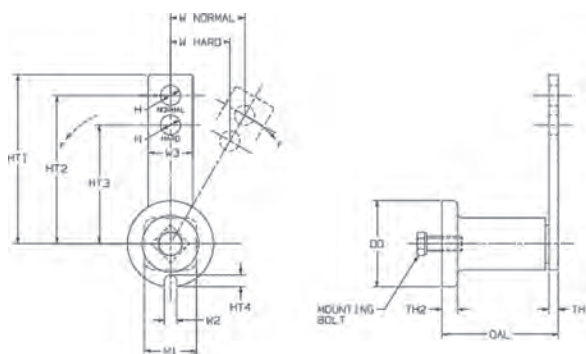
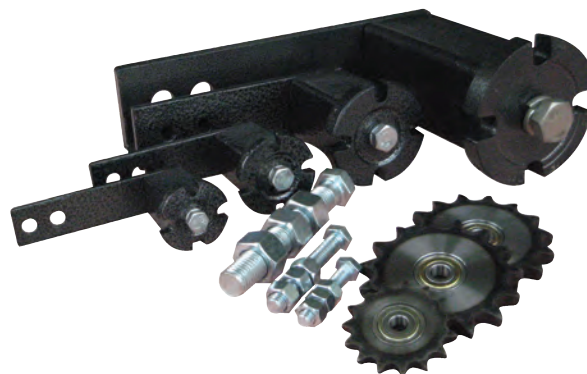

Type	OD	OAL	TH1	HT2	HT3	W3	HT1	W1	W2	TH2	HT4	H	Mounting Bolt	F in n/M 0 - 30°	Weight (kg)
CT11	35	50	5	80	60	20	90	20	7	7	6	8	M6	0-90	0.25
CT15	50	60	5	100	80	30	110	22	8	8	8	10	M8	0-140	0.45
CT18	60	75	6	100	80	40	115	35	9	10	11	10	M10	0-320	0.75
CT27	80	110	8	135	105	50	155	45	10	15	13	12	M12	0-820	1.8
CT38	105	140	10	180	140	65	200	62	13	16	15	20	M16	0-1500	3.7
CT45	115	200	12	225	190	70	260	78	17	18	20	20	M20	0-2500	6.5

Type	Angle of Pretension (Force required in psi)						Mounting Bolt Torque
	10°		20°		30°		
	Normal	Hard	Normal	Hard	Normal	Hard	
CT11	3.4	4.5	9.0	11.9	18.0	23.9	89
CT15	5.6	7.0	14.6	18.2	30.4	37.8	221
CT18	16.9	20.9	40.5	50.6	78.7	98.2	434
CT27	33.8	43.8	85.4	111.1	179.8	233.8	761
CT38	65.3	81.4	164.1	205.0	337.2	421.5	1,859
CT45	112.5	140.5	292.5	365.6	584.5	730.7	3,629

Tensioner Selection		
Chain	Belt	Tensioner
25-1	A	CT11
35-1-2-3	A, B	CT15
35-1-2-3	B, C	CT18
40-1-2-3		
40-3	D, E	CT27
50-1-2-3		
60-1-2-3		
80-1-2-3		CT38
80-3		CT45
100-1-2-3		
120-1-2-3		
140-1-2		
160-1-2		
180-1-2		
200-1-2		

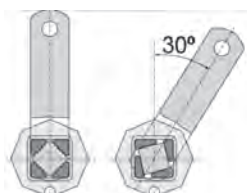

The optimum angle of pretension is 20° the maximum angle is 30°. At 20° the tensioner has maximum capability to absorb vibrations and shock loads, and still have enough arc motion to automatically take up belt or chain stretch.

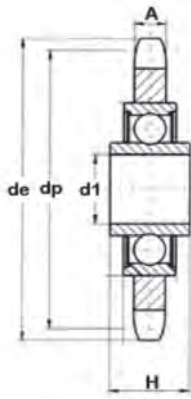

Idler Sprockets in conjunction with Tensioners provide an efficient solution to maintaining smooth running drives, inhibiting the effects of chain stretch and ensuring chains don't jump their drives.

These prefabricated Idler Sprockets employ a standard precision roller bearing.

Available in a range of sizes with pins to suit, this range of Idler Sprockets are designed for use in conjunction with the CT Series Tensioners.



Part No	Pitch	Teeth	de	dp	A	D1	Bolt	H
CT15/CT18-06B-15	3/8"	15	49.5	45.8	5.3	10	10X55	9
CT15/CT18-08B-15	1/2"	15	65.9	61.1	7.2	10	10X55	9
CT27-08B-15	1/2"	15	65.9	61.1	7.2	12	12X80	9
CT27-10B-15	5/8"	15	83.2	76.4	9.1	12	12X80	10
CT27-12B-15	3/4"	15	99.8	91.6	11.1	12	12X80	11.1
CT38-10B-15	5/8"	15	83.2	76.4	9.1	20	20X100	14
CT38-12B-15	3/4"	15	99.8	91.6	11.1	20	20X100	14
CT38-16B-13	1"	13	117.7	106.1	16.2	20	20X100	16
CT45-20B-13	1-1/4"	13	147.5	132.7	18.5	20	20X130	18

Belt Roller

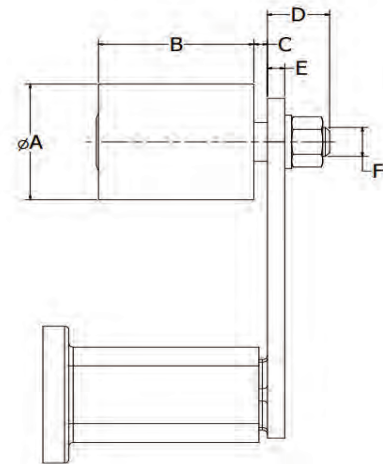

Part No	Max Speed	Max Belt Width	A	B	C	D	E	F	Weight
	RPM		mm						KG
CT11-BT30X35	8000	30	30	35	2	14	5	M8	0.08
CT15/18-BT40X45	8000	40	40	45	6	16	7	M10	0.17
CT27-BT60X60	6000	55	60	60	8	17	8	M12	0.4
CT38-BT80X90	5000	85	80	90	8	25	10	M20	1.15
CT45-BT80X135	4500	130	90	135	10	27	12	M20	1.75