

SAMT

Specialised Air Motors and Transmission

 **FLUIDOMAT**



Fixed Speed / Constant Fill Fluid Couplings



Shaft Mounted SM/SMD/SM-DX

These are shaft mounted coupling enabling axially compact drive space. Rubber coupling on one end.

Radially Displaceable HF /HFD /HF-DX

These are radially displaceable coupling enabling prealignment of driving and driven shafts. Metallic disc flexible coupling on both ends. Weight of coupling shared by driving and driven shafts.



- To satisfy starting and running characteristics of industrial machines Fluidomat offer three circuit types to give starting torque down to 120% of nominal torque.
- Type SM and HF are basic coupling without delayfil chamber. Starting torque adjustable in the range of 170% to 270%.
- Type SMD and HFD are couplings with delayfil chamber. Starting torque adjustable in the range of 140% to 270%.
- Type SM-DX and HF-DX are couplings with extended delayfil chamber. Starting torque adjustable in the range of 120% to 270%.
- Normal operating slip - 2% to 5% depending on coupling size and starting torque value.
- Fusible plug blow off temperature 130°C as standard. Optional 160°C.
- Suitable for two consecutive starts from hot and three from cold.

Different Executions of Oil Circuit

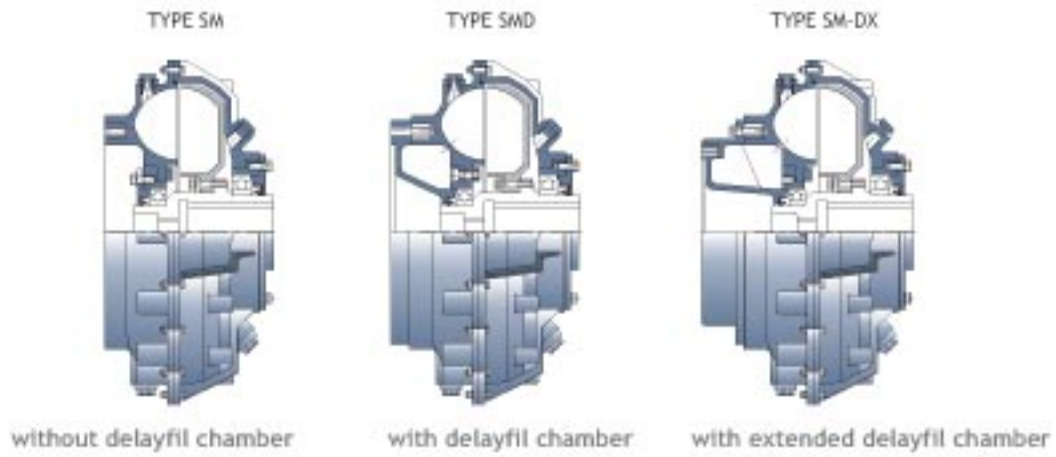

Oil Circuit and Oil Levels with Delayfil Chamber



STARTING TORQUE CHARACTERISTICS WITH & WITHOUT DELAYFIL CHAMBER

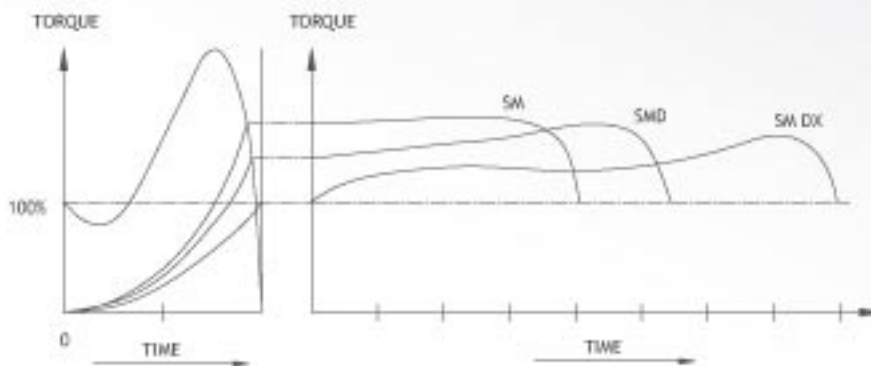

TYPICAL VALUES

FLUIDOMAT SM & HF

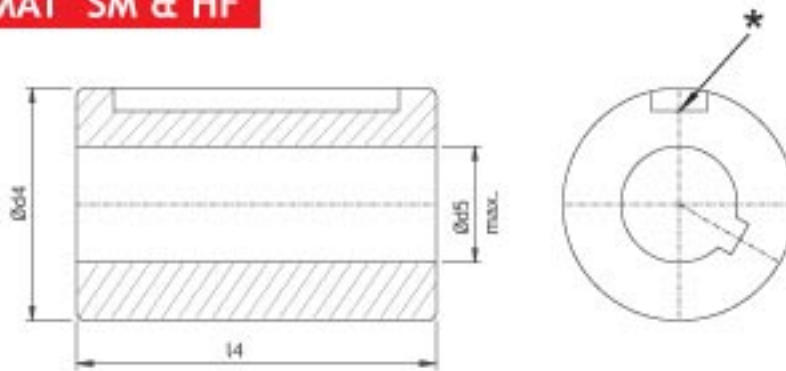

Coupling types SM/SMD/SM-DX are supplied in finished bores on the fluid coupling shaft. However where it is not possible to specify finished bores at the time of ordering, we can provide a separate shaft bush with $OD > \text{Ø}d4$ and * narrow keyway. The allowable maximum bore in the shaft bush is denoted by $\text{Ø}d5$ shown in the dimension table.



COUPLING MODEL SM/SMD/SM-DX HF/HFD/HF-DX	Maximum ratings in KW at different input speeds RPM.							
	600 RPM	730 RPM	900 RPM	970 RPM	1200 RPM	1470 RPM	1800 RPM	*3000 RPM
3	-	1	2	3	6	10	15	45
4	1	2	4	5	9	15	22	55
5	2	4	7	9	17	30	42	90
6	3	5	9	11	22	40	60	125
7	4	8	15	18	34	62	85	160
8	6	11	21	26	49	90	120	-
8 B	9	16	29	36	68	125	180	-
9	12	22	41	52	98	172	246	-
9 B	16	29	54	68	129	228	300	-
10	22	39	73	91	172	275	370	-
10 B	32	57	107	134	253	373	500	-
11	47	85	158	198	374	475	-	-
12	82	148	278	348	600	750	-	-
13	163	293	550	620	850	1100	-	-
14	277	500	758	850	1250	-	-	-
15	472	850	1148	1250	-	-	-	-
16	583	1050	1400	1500	-	-	-	-
16 DC	900	1500	1862	2000	-	-	-	-

* Coupling for 3000 RPM should be selected only after our approval is obtained.

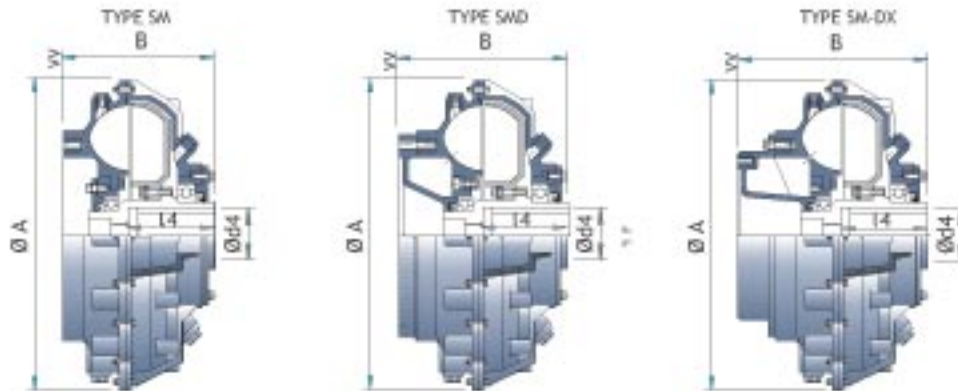

☞ Reference face for flexible coupling.

Technical Specification and Dimension Table for SM/SMD/SM-DX couplings

SM-SMD-SM-DX	Ø A	B			Ød4 max.	Ød5 max.	L4 max.	Dry Wt. In Kgs. With connected Flexible Coupling			Max. Oil Filling in Liters			Threads 'M' - For Coupling Withdrawl	Connected Flexible Coupling Model
		SM	SMD	SM-DX				SM	SMD	SM-DX	SM	SMD	SM-DX		
3	342	158	213	247	42	28	80	24	27	28	2.8	3.2	3.2	3/4"	FFX-1
4	367	160	215	249	50	34	90	30	34	35	3.8	4.2	4.2	3/4"	FFX-1
5	406	190	220	280	65	50	110	40	44	45	4.9	5.4	5.4	1"	FFX-2
6	435	213	239	310	70	50	120	55	59	61	5.6	7.1	7.1	1"	FFX-3
7	471	218	263	333	80	57	135	66	71	73	8.3	8.8	8.8	1"	FFX-3
8	505	238	279	359	80	57	140	77	83	85	9.8	10.8	10.8	1"	FFX-4
8 B	553	250	290	380	95	68	155	96	102	105	12.2	13.2	13.2	1 1/4"	FFX-4
9	584	255	305	385	95	68	155	104	110	113	15.8	16.8	16.8	1 1/4"	FFX-4
9 B	620	270	335	430	95	68	160	150	165	168	17.6	18.1	18.1	1 1/2"	FP-1 / FFX-5
10	644	280	329	424	110	80	170	170	180	185	22.0	24.0	24.0	1 1/2"	FP-1 / FFX-5
10 B	714	310	355	451	110	80	190	210	225	230	27.0	31.0	31.0	1 1/2"	FP-2A
11	751	320	375	471	120	95	200	254	268	273	35.0	40.0	40.0	Ø50-8P	FP-2A
12	845	359	435	555	130	-	240	310	345	355	55.0	57.0	57.0	Ø50-8P	FP-2B
13	960	441	489	619	150	-	270	440	480	495	87.0	92.0	92.0	Ø50-8P	FP-3
14	1104	451	494	624	160	-	275	682	730	745	130.0	137.0	137.0	Ø65-16P	FP-4A
15	1230	485	594	724	160	-	275	850	920	940	175.0	182.0	182.0	Ø75-16P	FP-4B
16	1298	-	571	-	190	-	320	-	1250	-	-	195.0	195.0	Ø75-16P	FP-4B
16 DC	1298	-	830	-	190	-	320	-	1800	-	-	350.0	350.0	Ø75-16P	-

BSW Up to model 10B and 5q. threads onwards.

FLEXIBLE COUPLING

CONNECTED FLEXIBLE COUPLING MODEL WISE

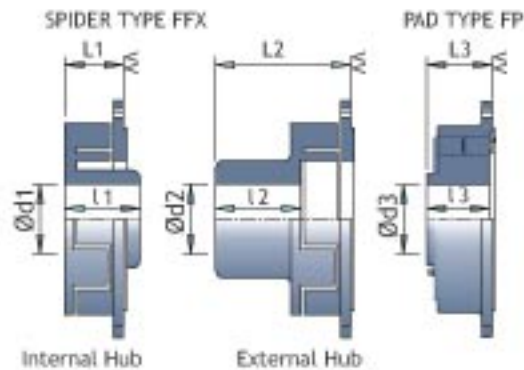

Model SM-SMD-SM-DX	Internal Hub			External Hub			Model SM-SMD-SM-DX	Pad Type Coupling		
	Ø d1 Max.	L1	L1	Ø d2 Max.	L2	L2		Ø d3 Max.	L3	L3
3,4	48	67	67	60	75	130	9B,10	100	110	120
5	60	72	72	75	90	150	10B,11	120	140	151
6,7	80	92	72	90	110	170	12	140	155	167
8,8B,9	90	102	87	100	120	195	13	160	180	179
9B,10	-	-	-	125	150	230	14	160	180	194
							15,16	180	200	214

TYPE HF

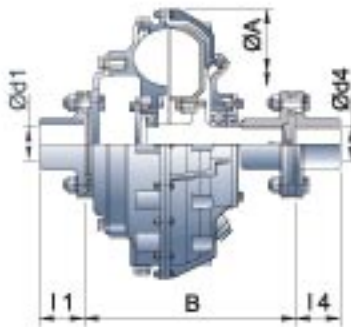

TYPE HFD

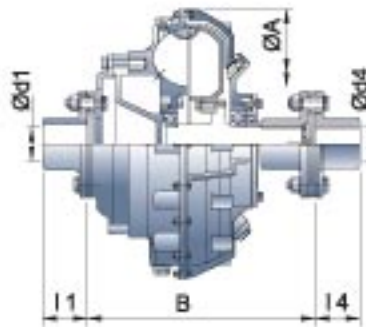

TYPE HF-DX

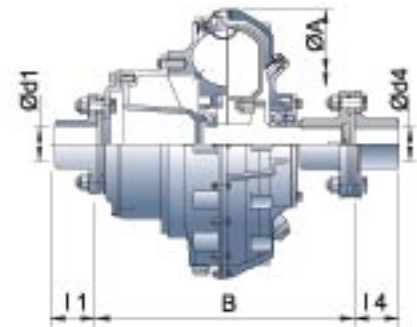

Technical Specification and Dimension Table for HF/ HFD/ HF-DX couplings

HF HFD HF-DX	Ø A	B*			Ø d1 & Ø d4 max.	l1 & l4	Dry Wt. In Kgs. With connected Flexible Coupling			Max. Oil Filling In Liters			Connected Flexible Coupling Model
		HF	HFD	HF-DX			HF	HFD	HF-DX	HF	HFD	HF-DX	
3	342	239	295	329	55	70	25	28	29	2.8	3.2	3.2	FXC-I
4	367	264	320	354	60	70	34	37	39	3.8	4.2	4.2	FXC-II
5	406	285	315	375	60	70	48	51	54	4.9	5.4	5.4	FXC-II
6	435	332	358	429	75	95	64	67	70	5.6	7.1	7.1	FXC-III A
7	471	345	390	460	75	95	81	84	86	8.3	8.8	8.8	FXC-III A
8	505	366	407	487	80	95	96	102	107	9.8	10.8	10.8	FXC-III
8 B	553	405	445	535	90	110	116	122	127	12.2	13.2	13.2	FXC-III
9	584	395	445	526	90	110	124	130	135	15.8	16.8	16.8	FXC-III
9 B	620	446	511	589	110	125	168	180	184	17.6	18.1	18.1	FXC-IV A
10	644	468	517	611	110	125	172	184	188	22.0	24.0	24.0	FXC-IV A
10 B	714	491	537	632	110	125	217	233	237	27.0	31.0	31.0	FXC-IV A
11	751	511	566	661	112	125	281	292	300	35.0	40.0	40.0	FXC-IV
12	845	614	700	820	145	200	400	421	430	55.0	57.0	57.0	FXC-V
13	960	697	745	875	145	200	570	596	605	87	92.0	92.0	FXC-V
14	1104	770	813	943	180	200	640	688	703	130.0	137.0	137.0	FXC-VI
15	1230	-	901	1031	180	200	810	880	900	175.0	182.0	182.0	FXC-VI

* Coupling for 3000 RPM should be selected only after our approval is obtained.

BRAKE DRUM MOUNTING

Flexible Coupling Model	Spider Type Coupling				
	ØE	C	Z	I2	L2
FFX-1	200	75	20	75	130
	250	95	0	75	130
FFX-2	250	95	20	90	150
	300	118	05	90	158
FFX-3	315	118	05	90	158
	300	118	17	110	170
	315	118	17	110	170
FFX-4	400	150	05	110	190
	300	118	42	120	195
	315	118	42	120	195
	400	150	10	120	195
* FFX-5	500	190	05	120	230
	400	150	29	150	230
	500	190	05	150	246

* For Fluid Coupling Model SM/SMD/SM-DX -9B & 10

TYPE SM/SMD/SM-DX WITH BRAKE DRUM (Inner Wheel Drive)

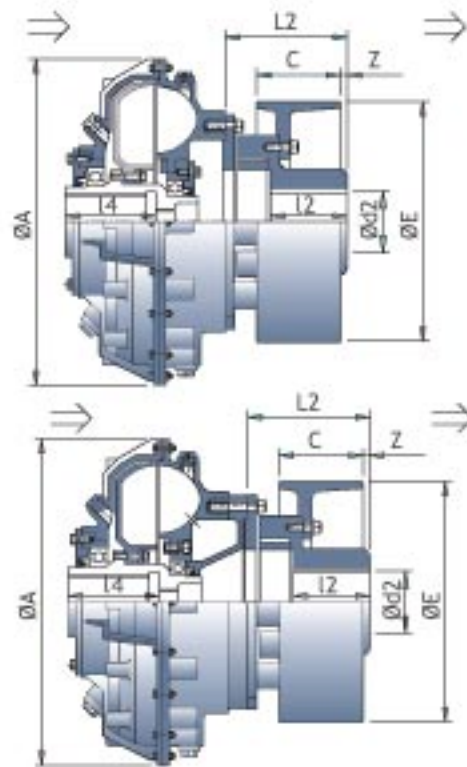

TYPE HF/HFD/HF-DX WITH BRAKE DRUM (Outer Wheel Drive)

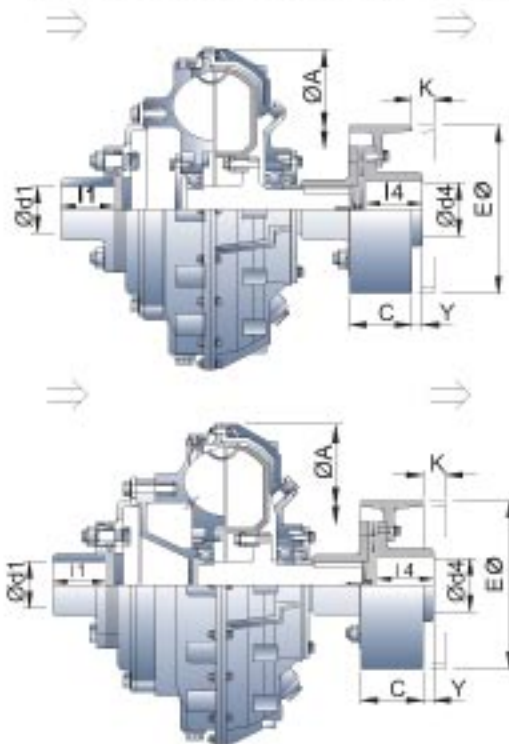

* For radial displacement of Fluid Coupling the Brake drum shall need to be shifted by dimension 'K' As shown. The Machine/G.B. shaft length /space should be adequate for this shift of B.D.

Flexible Coupling Model	Metallic disc Coupling			
	ØE	C	Y	K* Min
FXC-I	160	75	21	26
	200	75	21	26
FXC-II	200	75	19	26
	250	95	10	35
FXC-III A	250	95	35	35
	300	118	32	55
FXC-III	315	118	32	55
	250	95	48	35
	300	118	30	55
FXC-III A	315	118	30	55
	400	150	18	73
	300	118	52	55
	315	118	52	55
FXC-IV	400	150	40	65
	500	190	05	70
	600	236	(-)31	80
	630	236	(-)31	80
FXC-V	500	190	70	70
	600	236	34	70
	630	236	34	70
	710	265	25	90



SM-AR / HF-AR COUPLING

Type AR Fluid Couplings are with annular ring and extra long delayfil chamber.

During the initial rotation, the annular ring fills up and the working circuit is partially emptied enabling very low torque transmission during motor run up (acceleration). This enables very quick acceleration of motor speed and quick decay of motor current.

This is followed by increase in transmitted torque by gradual emptying of delayfil chamber oil into the working circuit. The torque is built up gradually and enables controlled acceleration torque to the driven machine. These couplings are very useful for conveyor drives.

Starting torque characteristic curve for fluid coupling type SM-AR & HF-AR for Conveyor Belt Application.

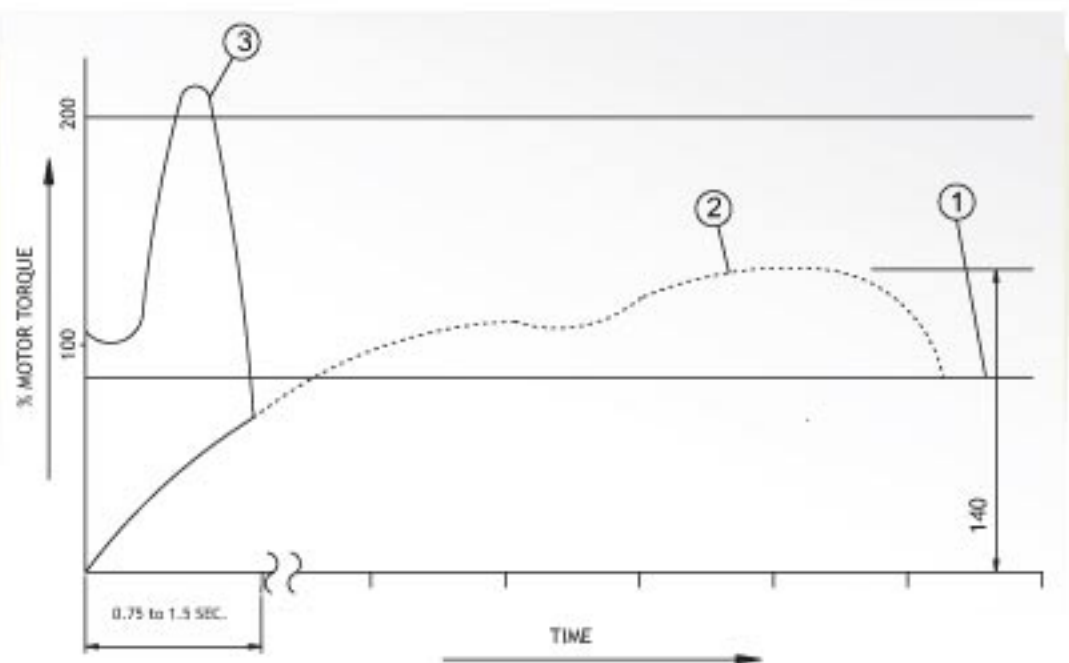

- 1 LOADED CONVEYOR.
- 2 FLUID COUPLING STARTING TORQUE CHARACTERISTICS FOR LOADED CONVEYOR.
- 3 MOTOR TORQUE CHARACTERISTICS.

TYPE SM-DX AR

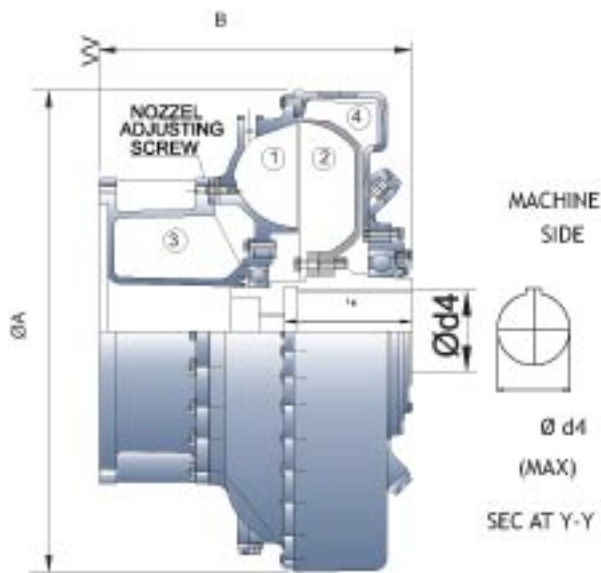

- 1) IMPELLER
- 2) ROTOR
- 3) DELAY FIL CHAMBER
- 4) ANNULAR CHAMBER

MODEL: SM-9 TO 12 DX - AR

RATING TABLE:

COUPLING MODEL	MAX. RATINGS IN KW AT DIFFERENT INPUT SPEEDS RPM						
	600 RPM	730 RPM	900 RPM	970 RPM	1200 RPM	1470 RPM	1800 RPM
SM-9 DX-AR	12	22	41	52	98	172	246
SM-10 DX-AR	22	39	73	91	172	275	370
SM-10B DX-AR	32	57	107	134	253	373	500
SM-11 DX-AR	47	85	158	198	374	475	-
SM-12 DX-AR	82	148	278	348	600	750	-
SM-13 DX-AR	163	293	550	620	850	1100	-

DIMENSION TABLE:

MODEL	Ø A	B	Ø d4	l-4	DRY WT. (Kgs)
SM-9 DX-AR	600	385	95	155	145
SM-10 DX-AR	650	428	110	170	212
SM-10-B DX-AR	724	451	110	190	265
SM-11 DX-AR	761	494	120	200	305
SM-12 DX-AR	875	567	130	240	395
SM-13 DX-AR	1000	640	150	270	525

FLEXIBLE COUPLING

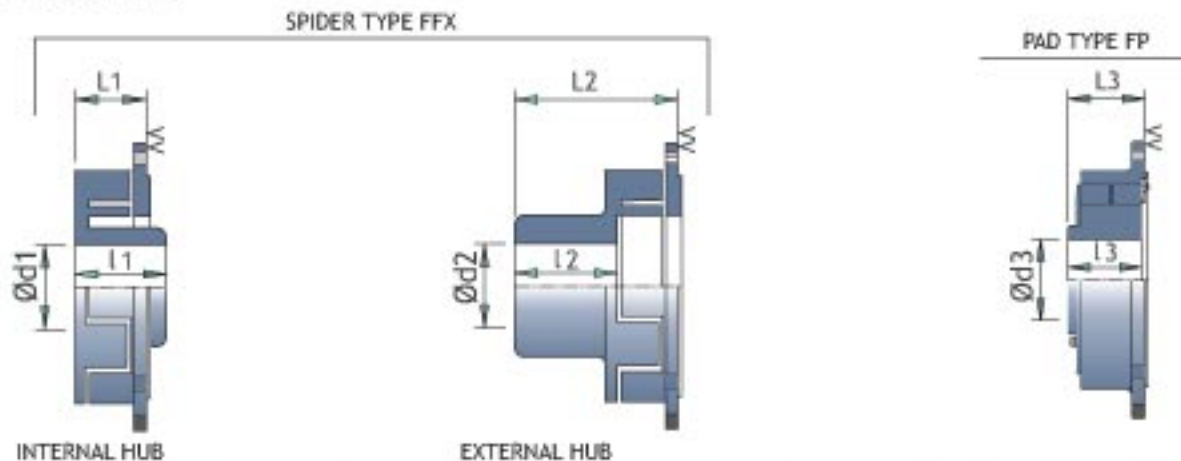

MODEL	FLEX. COUP. FFX-	INTERNAL HUB				EXTERNAL HUB				FLEX. COUP. FP-	PAD TYPE COUPLING			
		Ø d1 MAX.	l 1	L1	Wt. IN kg.	Ø d2 MAX.	l 2	L2	Wt. IN kg.		Ø d3 MAX.	l 3	L3	Wt. IN kg.
SM-9 DX-AR	FFX-4	90	102	87	-	100	120	195	-	-	-	-	-	
SM-10 DX-AR	FFX-5	-	-	-	-	125	150	230	-	FP-1	100	110	120	-
SM-10B DX-AR	-	-	-	-	-	-	-	-	-	FP-2	120	140	151	-
SM-11 DX-AR	-	-	-	-	-	-	-	-	-	FP-2	120	140	151	-
SM-12 DX-AR	-	-	-	-	-	-	-	-	-	FP-3	140	155	167	-
SM-13 DX-AR	-	-	-	-	-	-	-	-	-	FP-4	160	180	179	-

TYPE HF DX AR

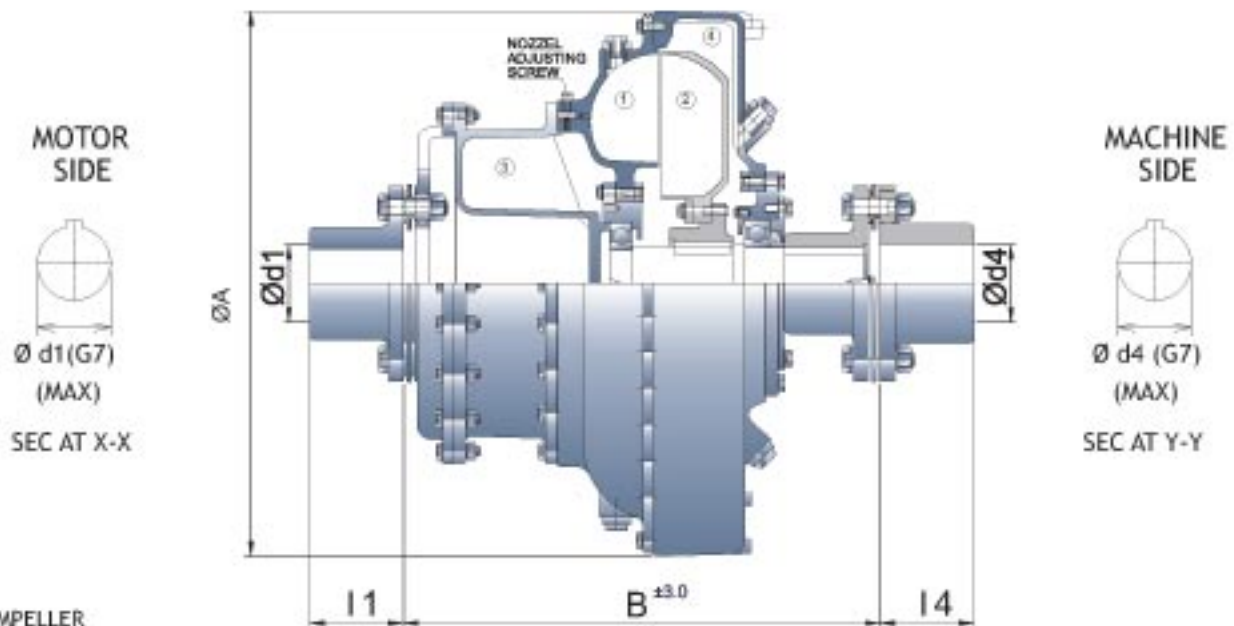

- 1) IMPELLER
- 2) ROTOR
- 3) DELAY FIL CHAMBER
- 4) ANNULAR CHAMBER

RATING TABLE:

COUPLING MODEL	MAX. RATINGS IN KW AT DIFFERENT INPUT SPEEDS RPM						
	600 RPM	730 RPM	900 RPM	970 RPM	1200 RPM	1470 RPM	1800 RPM
HF-9 DX-AR	12	22	41	52	98	172	246
HF-10 DX-AR	22	39	73	91	172	275	370
HF-10B DX-AR	32	57	107	134	253	373	500
HF-11 DX-AR	47	85	158	198	374	475	-
HF-12 DX-AR	82	148	278	348	600	750	-
HF-13 DX-AR	163	293	550	620	850	1100	-

DIMENSION TABLE:

MODEL	Ø A	B	Ø d1 / Ø d4	l 1 / l 4	DRY WT. (Kgs)
HF-9 DX-AR	600	526	90	110	191
HF-10 DX-AR	670	609	110	125	224
HF-10B DX-AR	724	632	110	125	280
HF-11 DX-AR	761	684	120	125	326
HF-12 DX-AR	875	832	150	170	485
HF-13 DX-AR	1000	912	145	200	655





- SMP are fluid couplings for belt drive offering a wide range of pulley diameters.
- Have an in built delayfil chamber enabling quick decay of motor starting current as motor accelerates to 90% speed faster.
- Suitable for two consecutive starts from hot and three from cold.
- Fusible plug blow off temp. is 130°C as standard. optional 160° C.

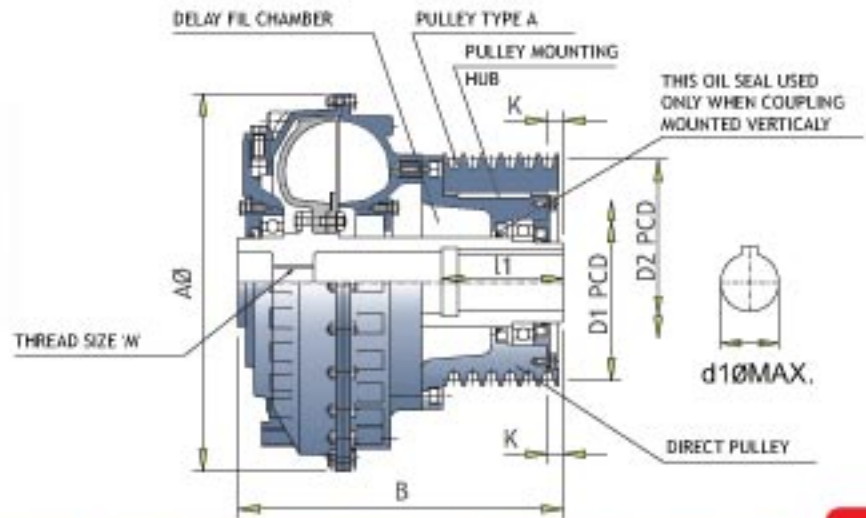

Coupling model SMP	Max rating in KW at different input speeds in RPM						A	B	d1 max.	l1	Dry Wt. KG.	Max. Oil Filling in Liters	Threads M BSW
	750	900	1000	1200	1500	1800							
1R	0.6	1	1.5	2.5	5	8	280	166	38	91	18	2.2	1/2"
2R	0.9	1.6	2.2	3.8	7.5	12	310	205	38	91	25	2.8	3/4"
3 R/S	1.2	2.1	3	5	10	15	330	262	42/38	110	30	3.3	3/4"
4 R/S	2.3	4	5.5	9.5	18.5	25	360	284	42/38	110	35	4.1	3/4"
5R	4.1	7	10	17	30	38	395	331	65	142	46	6.5	1"
6R	5.6	10	13	23	45	60	420	374	65	142	65	8.3	1 1/2"
7R	8.3	15	20	34	65	85	465	395	75	142	92	11.1	1 1/2"
8R	11.2	19	26	46	90	120	505	430	85	142	115	14.6	1 1/2"
8B-R	16	29	36	68	125	180	553	495	90	155	121	18	1 1/2"
9R	19	33	45	78	150	200	570	512	90	170	127	22.0	1 1/2"
10R	36	62	85	147	250	325	630	532	110	210	220	28.5	1 1/2"
11R	87	150	205	355	450	-	740	590	110	210	275	44.8	Ø50-8P

Fixed Speed / Constant Fill Fluid Couplings

MODEL	PULLEY GROOVE SEC	DIRECT PULLEY MOUNTING				PULLEY GROOVE SEC	PULLEY TYPE-A			
		MAX. NO. OF GROOVES	D1 PCD.		K ±1.5		MAX. NO. OF GROOVES	D2 PCD.		K ±1.5
			Max.	Min.				Max.	Min.	
SMP-1R	SPA/A	3	260	140	16.0	-	-	-	-	-
	SPB/B	2	260	146	19.0	-	-	-	-	-
	SPC/C	1	260	156	23.0	-	-	-	-	-
SMP-2R	SPA/A	4	300	140	16.0	-	-	-	-	-
	SPB/B	3	300	147	19.0	-	-	-	-	-
	SPC/C	2	300	157	23.0	-	-	-	-	-
SMP-3R	SPB	3	160	145	26.0	A	5	260	160	18.0
	SPB	4	140	140	26.0	B	4	260	165	21.0
SMP-4R	B	4	140	140	26.0	C	3	260	170	26.0
	B	3	160	145	26.0	SPA	5	260	160	18.0
	C	2	140	140	31.0	SPB	4	260	165	21.0
SMP-3S SMP-4S	C	2	160	145	31.0	SPC	3	260	170	26.0
	SPA/A	5	139	125	25.0	-	-	-	-	-
	SPB/B	4	139	128	27.0	-	-	-	-	-
SMP-5R	SPZ/Z	6	139	125	23.0	-	-	-	-	-
	B	5	180	175	23.0	A	7	325	205	20.0
	C	3	200	185	27.0	B	5	325	209	23.0
	C	4	185	180	27.0	C	4	325	215	27.0
	SPB	5	180	180	23.0	SPA	7	325	207	20.0
	SPC	3	200	195	27.0	SPB	5	325	213	23.0
SMP-6R	SPC	4	190	190	27.0	SPC	4	325	223	27.0
	A	8	200	170	32.0	A	8	350	215	20.0
	A	5	225	205	30.0	B	6	350	220	22.0
	B	6	200	175	34.0	C	5	350	225	27.0
	B	6	225	210	32.0	SPA	8	350	216	20.0
	C	5	200	180	32.0	SPB	6	350	222	22.0
	C	5	225	215	30.0	SPC	5	350	232	27.0
	SPA	8	200	175	32.0	-	-	-	-	-
	SPA	8	225	210	30.0	-	-	-	-	-
	SPB	6	200	180	34.0	-	-	-	-	-
SMP-7R	SPB	6	225	215	32.0	-	-	-	-	-
	SPC	5	200	190	32.0	-	-	-	-	-
	SPC	5	225	225	30.0	-	-	-	-	-
	B	6	228	195	26.0	B	6	380	224	26.0
	C	5	224	205	30.0	C	5	380	230	30.0
SMP-8R	C	5	200	200	30.0	SPB	6	380	230	26.0
	SPB	6	228	200	26.0	SPC	5	380	240	30.0
	SPC	5	225	215	30.0	-	-	-	-	-
	B	8	250	240	20.0	B	8	420	260	18.0
	B	8	235	225	20.0	C	6	420	265	22.0
	C	6	250	240	24.0	SPB	8	420	265	18.0
	C	6	235	230	24.0	SPC	6	420	275	22.0
	SPB	8	250	240	20.0	-	-	-	-	-
SMP-8B-R & SMP-9R	SPB	8	235	230	20.0	-	-	-	-	-
	SPC	6	250	240	24.0	-	-	-	-	-
	SPC	6	235	235	24.0	-	-	-	-	-
SMP-10R	B	10	250	235	28.0	B	10	500	260	25.0
	C	8	250	240	32.0	C	8	500	265	29.0
SMP-11R	SPB	10	250	240	28.0	SPB	10	500	265	25.0
	SPC	8	250	250	32.0	SPC	8	500	275	25.0
SMP-10R	SPB/B	12	350	285	19.0	SPB/B	12	520	360	19.0
	SPC/C	9	345	295	23.0	SPC/C	9	520	360	23.0
SMP-11R	PULLEY SIZE ON REQUEST									



- Starting torque adjustable in the range of 170-250%.
Normal operating slip is 2 to 5% depending on coupling size and starting torque value.
- Suitable for two consecutive starts from hot and three from cold.
- Fusible plug blow off temperature is 130°C standard.
Optional: 160°C.

COUPLING MODEL	Maximum ratings of couplings at different input speeds (In KW.)		
	730 RPM	970 RPM	1470 RPM
T12-			
01	0.6	1.4	5.0
02	0.9	2.1	7.5
03	1.1	2.6	9.3
04	1.8	4.3	15.0
05A	3.3	7.5	27.0
05	4.6	11.0	37.5
06	7.3	17.4	60.0
07	9.8	23.2	80.0
08	19.0	45.0	153.0
08B	28.3	65.0	228.0
09	37.0	90.0	265.0
10A	64.0	150.0	373.0
010	90.0	209.0	485.0
011	148.0	348.0	-
012	260.0	610.0	-
013	500.0	850.0*	-
014	850.0	1000.0*	-

Fixed Speed / Constant Fill Fluid Couplings

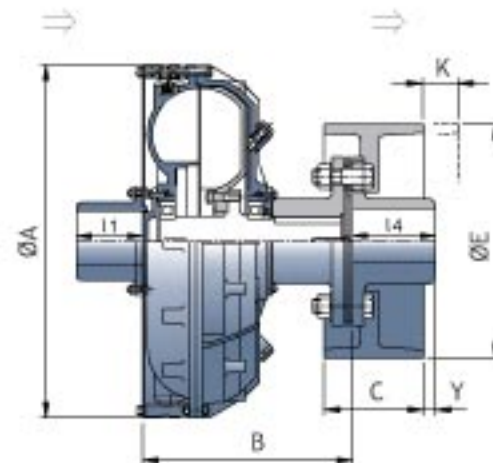
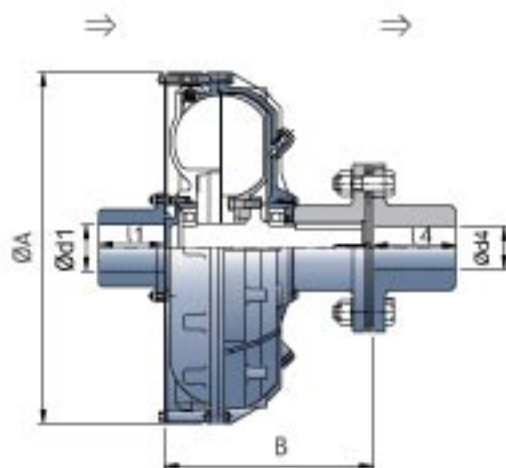

T12 Fluid Coupling

Model T12-	A	B	Ød1 max.	l1	Ød4 max.	l4	Dry WL. KG.	Max. Oil Filling In Liters	Connected Flexible Coupling Model
01	280	167	35	50	55	70	17	1.50	FXC-I
02	310	181	35	50	55	70	20	3.00	FXC-I
03	330	199	50	80	55	70	26	2.90	FXC-I
04	350	216	50	80	60	70	31	3.70	FXC-II
05A	395	237	50	80	60	70	48	5.10	FXC-II
05	420	276	75	110	75	95	67	5.90	FXC-III A
06	465	290	75	110	75	95	75	8.40	FXC-III A
07	510	314	75	110	80	95	85	11.00	FXC-III
08	570	347	110	140	90	110	138	15.00	FXC-III
08B	615	353	110	140	110	125	176	18.60	FXC-IWA
09	650	371	110	140	110	125	183	22.20	FXC-IWA
010A	700	368	110	140	110	125	198	26.30	FXC-IWA
010	750	414	110	140	112	125	234	33.00	FXC-IV
011	860	488	125	210	145	200	395	50.00	FXC-V
012	970	568	150	210	145	200	480	75.00	FXC-V
013	1104	594	150	210	180	200	598	108.0	FXC-VI
014	1230	655	175	210	180	200	995	160.0	FXC-VI

TYPE T12 WITH BRAKE DRUM

Flexible Coupling Model	Metallic disc Coupling			
	ØE	C	Y	K* Min
FXC-I	160	75	21	26
	200	75	21	26
FXC-II	200	75	19	26
	250	95	10	35
FXC-III A	250	95	35	35
	300	118	32	55
FXC-III	315	118	32	55
	250	95	48	35
FXC-III	300	118	30	55
	315	118	30	55
FXC-IWA	400	150	18	73
	300	118	52	55
FXC-IWA	315	118	52	55
	400	150	40	65
FXC-IV	500	190	05	70
	400	150	40	65
FXC-IV	500	190	05	70
	600	236	(-)31	80
FXC-V	630	236	(-)31	80
	500	190	70	70
FXC-V	600	236	34	70
	630	236	34	70
FXC-V	710	265	25	90

* For radial displacement of Fluid Coupling the Brake drum shall need to be shifted by dimension 'K' As shown. The Machine/G.B. shaft length /space should be adequate for this shift of B.D.





The Steel Body Constant Fill Fluid Couplings

Type SF: are steel body constant fill Traction Coupling with a thin driving plate on motor side and metallic disc coupling on machine side. These couplings are radially displaceable. Maximum capacity is adjustable between 180% to 270%.

Type CBSF: are steel body constant fill fluid couplings with hollow shaft execution on one end and flexible coupling on the other end for respective shaft connections. They are available with delayfil chamber type CBSF DF and without delayfil type CBSF. Also available in Radially Displaceable execution having metallic disc flexible coupling on both ends.

They are suitable for operation with:

- Water - Oil emulsion as per HFB classification of European Mines safety commission.
- Mineral oil as operating fluid.
- Maximum torque transmitting capacity is adjustable between 180% to 270 % for CBSF and 150 to 270% CBSF DF delayfil couplings.

Type WF: are steel body constant fill fluid couplings with hollow shaft execution on one end and flexible coupling on the other end for respective shaft connection. They are available with delayfil chamber type WFDF and without delayfil type WF. Also available in Radially Displaceable execution having metallic disc flexible coupling on both ends.

They are suitable for operation with:

- Water (aqua)
- Water oil emulsion as per HFB classification of European Mines Safety Commission.
- Mineral Oil
- Maximum torque transmitting capacity is adjustable between 200% to 270% for type WF and 180% to 270% for WF DF.

These steel body fluid couplings are of extremely robust construction. They are ideal for use in underground or opencast mines or other sites where use of aluminum is prohibited or where robust construction is necessary with simplicity of construction. These steel body fluid couplings are being manufactured by us since 1976 and are very well proven on various mining and surface applications.

They offer all the advantages and performance characteristics of any other aluminium body Fluidomat Fluid Couplings

- Virtually no load start and run up of motor and utilization of motor peak torque for load acceleration.
- Smooth and controlled acceleration of driven machine.
- Quick decay of motor starting current kick.
- Adjustable starting characteristics and load limiting.
- Dampening of shock loads, torsional fluctuations and vibrations.

KW Ratings at different speeds (RPM)

SF/CBSF & CBSDF							
Model	600	750	900	1000	1200	1500	1800
4	1	1.8	3	4	8	15	22
6	2.6	5	9	12	20	40	60
7	4	7.5	13	18	31	60	80
8	5.6	11	19	26	45	80	114
9	10	19	33	45	78	152	197
10	14.4	28	48	66	115	224	290
11*	33	64	111	152	262	373	--
12*	46	90	155	213	368	485	--

* Models not offered in type SF

WF/WDF							
Model	600	750	900	1000	1200	1500	1800
4	1	1.8	3	4	8	15	22
360	2.6	5	9	12	20	40	55
5	4	7.5	13	18	31	55	75
6	5.6	11	19	26	45	75	100
7	10	19	33	45	78	140	175
8	14.4	28	48	66	115	205	230
9	33	64	111	152	235	335	440
10	46	90	155	213	331	480	-

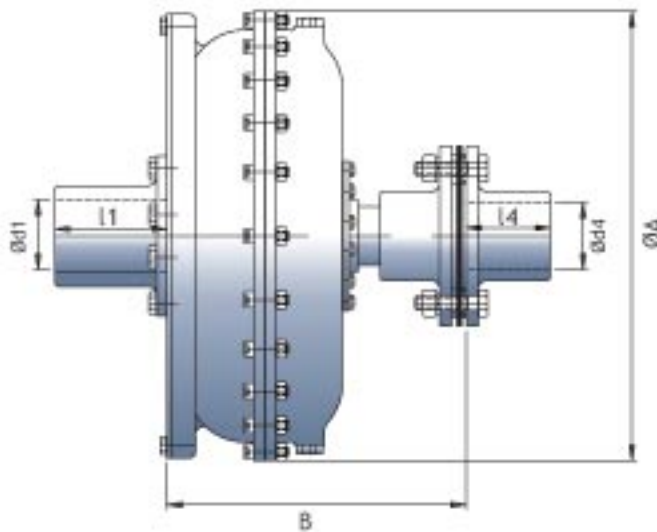

Technical Specification and Dimension Table for coupling type SF

Fluid Coupling Model SF	ØA	B	Ød 1 MAX	l1	Ød 4 MAX	l 4	Flex. Coupling Model FXC	Dry Wt. Kg	Max filling liters
4	375	250	50	80	55	70	II	55	3.5
6	418	290	75	110	90	95	III	82	5.6
7	470	300	75	110	90	95	III	98	7.2
8	508	310	75	110	90	95	III	106	10.7
9	570	330	110	140	110	110	III	190	11.5
10	620	345	110	140	110	125	IV	205	17.7

Model	A	B	Ød4 Max	L4	Threads "M" BSW	Flexible coupling model
WF-4, CBSF-4	380	154	42	80	1"	FFX-1
WFDF-4, CBSFDF-4	380	240	42	80	1"	FFX-1
WF-360, CBSF-6	436	220	55	112	1"	FFX-3
WFDF-360, CBSFDF-6	436	316	55	112	1"	FFX-3
WF-5, CBSF-7	470	235	75	135	1"	FFX-3
WFDF-5, CBSFDF-7	470	280	75	135	1"	FFX-3
WF-6, CBSF-8	508	260	85	142	1¼"	FFX-4
WFDF-6, CBSFDF-8	508	377	85	142	1¼"	FFX-4
WF-7, CBSF-9	570	276	90	155	1½"	FFX-4
WFDF-7, CBSFDF-9	570	396	90	155	1½"	FFX-4
WF-8, CBSF-10	620	310	100	170	1½"	FP-1
WFDF-8, CBSFDF-10	620	375	100	170	Ø50-8P	FP-1
WF-9, CBSF-11	730	342	120	200	Ø50-8P	FP-2
WFDF-9, CBSFDF-11	730	494	120	200	Ø50-8P	FP-2
WF-10, CBSF-12	776	405	120	200	Ø50-8P	FP-2
WFDF-10, CBSFDF-12	776	590	120	200	Ø50-8P	FP-2

TYPE:- WF, CBSF

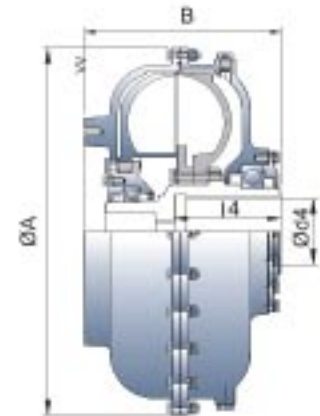

TYPE:-WFDF, CBSF DF

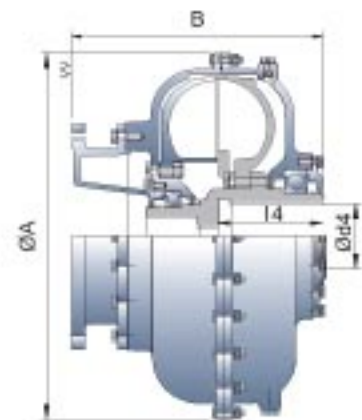

FLEXIBLE COUPLING

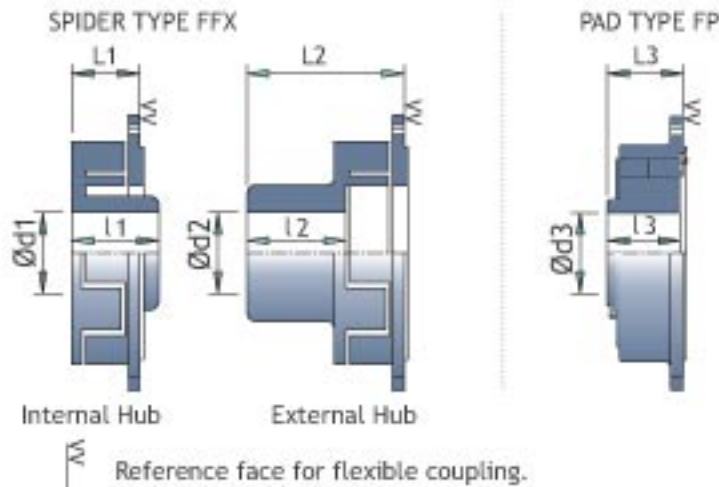

Flexible Coupling model	Internal Hub			External Hub			Pad type coupling		
	Ø d1 max	l1	L1	Ø d2 max	l2	L2	Ø d3 max	l3	L3
FFX-1	42	67	67	60	75	130
FFX-3	80	92	72	90	110	170
FFX-4	90	102	87	100	120	195
FFX-5	125	150	230
FP-1	100	110	120
FP-2	140	155	167

Type WF HF & CBSF HF are radially displaceable fluid couplings with metallic disc flexible coupling on both input and output ends. These metallic disc couplings do not require any lubrication and require least maintenance. The weight of fluid coupling is shared by motor and driven machine shaft thus reducing weight reaction on gear box shafts which are of small diameters in modern designs.

TYPE : WF HF, CBSF HF

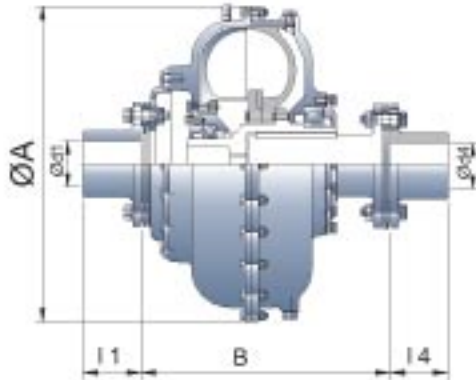

TYPE : WF HFD, CBSF HFD

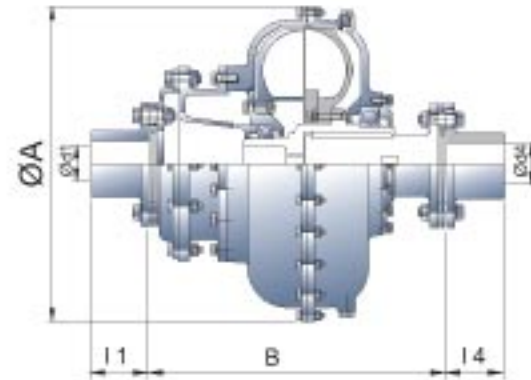

Model	ØA	B	Ød1 Max.	l 1	Ød4 Max.	l 4	Flexible coupling model
WFHF -4, CBSF HF-4	380	278	55	70	55	70	FXC-II
WF HFD -4, CBSF HFD-4	380	364	55	70	55	70	FXC-II
WFHF -360, CBSF HF-6	436	350	75	95	75	95	FXC-III A
WF HFD -360, CBSF HFD-6	436	446	75	95	75	95	FXC-III A
WFHF -5, CBSF HF-7	470	380	75	95	75	95	FXC-III A
WF HFD -5, CBSF HFD-7	470	500	75	95	75	95	FXC-III A
WFHF -6, CBSF HF-8	508	405	90	95	80	95	FXC-III
WF HFD -6, CBSF HFD-8	508	522	90	95	80	95	FXC-III
WFHF -7, CBSF HF-9	570	421	90	110	90	110	FXC-III
WF HFD -7, CBSF HFD-9	570	541	90	110	90	110	FXC-III
WFHF -8, CBSF HF-10	620	501	110	125	110	125	FXC-IV A
WF HFD -8, CBSF HFD-10	620	650	110	125	110	125	FXC-IV A
WFHF -9, CBSF HF-11	730	543	110	125	110	125	FXC-IV A
WF HFD -9, CBSF HFD-11	730	695	110	125	110	125	FXC-IV A
WFHF -10, CBSF HF-12	776	629	120	125	120	125	FXC-IV
WF HFD -10, CBSF HFD-12	776	814	120	125	120	125	FXC-IV



SPECIFICATION OF OIL RECOMMENDED FOR USE IN FLUIDOMAT CONSTANT FILL FLUID COUPLINGS.

As per ISOVG - 32

VISCOSITY : 32
 POUR POINT : < - 24 °c
 FLASH POINT : 190 °c

COMPATIBLE OIL SEAL - NITRILE & VITON RUBBER.

Equivalent Oil Grades and Brands

Supplier & Oil Grades	Viscosity C.St @ 40 °c	Viscosity Index (In °c)	Flash Point (In °c)	Pour Point (Min) (In °c)
HP ENCLO 32	32	95	190	(-) 3
HP-ENCLO VT 32	32	109	224	(-) 37
IOC- SERVOSYSTEM 32	29-33	95	190	(-) 6
IOC- SERVOSYSTEM HLP 32	29-33	100	200	(-) 21
SHELL TELLUS 32	32	99	209	(-) 30
CASTROL HYSPIH-AWH 32	32	95	180	(-) 3
BPL HYDROIL HLP 32	29-35	95	185	(-) 18

Other Equivalent Brands

Brand	Designation	Flash Point (In °c)
BP	BP- Energol HLP-32	216
CASTROL	Hyspin 32	220
CHEVRON	Mechanism LPS-32	200
ESSO	Esso Torque Fluid	220
MOBIL	Mobil Fluid 32	225
SHELL	Tegula Oil 32	196

Mass moment of Inertia J with oil in KG M²

Model	Outer Wheel	Inner Wheel
HF-3	0.25	0.05
HF-4	0.39	0.07
HF-5	0.66	0.23
HF-6	0.69	0.29
HF-7	1.32	0.35
HF-8	1.72	0.49
HF-8B	2.40	0.64
HF-9	2.82	0.76
HF-9B	4.65	1.91
HF-10	5.01	2.11
HF-10B	10.15	3.34
HF-11	11.66	3.93
HF-12	18.30	7.31
HF-13	35.74	14.25
HF-14	61.46	24.10
HF-15	93.13	37.24

Model	Outer Wheel	Inner Wheel
HFD-3	0.26	0.05
HFD-4	0.41	0.07
HFD-5	0.71	0.24
HFD-6	0.97	0.30
HFD-7	1.46	0.40
HFD-8	1.85	0.51
HFD-8B	2.61	0.72
HFD-9	3.06	0.93
HFD-9B	5.09	1.96
HFD-10	6.07	2.18
HFD-10B	11.30	3.44
HFD-11	12.97	4.07
HFD-12	20.33	7.61
HFD-13	39.82	14.78
HFD-14	68.04	24.98
HFD-15	102.70	38.61
HFD-16	-	-

Model	Outer wheel	Inner wheel
HFDX-3	0.27	0.05
HFDX-4	0.42	0.07
HFDX-5	0.74	0.24
HFDX-6	1.04	0.30
HFDX-7	1.59	0.40
HFDX-8	1.96	0.51
HFDX-8B	2.76	0.72
HFDX-9	3.24	0.93
HFDX-9B	5.55	1.96
HFDX-10	7.04	2.18
HFDX-10B	12.30	3.44
HFDX-11	14.07	4.07
HFDX-12	21.93	7.61
HFDX-13	43.02	14.78
HFDX-14	73.14	24.98
HFDX-15	-	-

Model	Outer wheel	Inner wheel
T12-01	0.11	0.02
02	0.15	0.03
03	0.19	0.04
04	0.27	0.05
05A	0.57	0.12
05	0.78	0.25
06	1.32	0.34
07	1.72	0.47
08	2.44	0.65
08B	4.11	1.69
09	5.01	2.11
10A	8.57	2.82
10	10.18	3.43
11	20.95	8.37
12	35.74	14.25
13	61.35	24.10
14	93.13	37.24

Model	Outer wheel	Inner wheel
SM-3	0.22	0.04
SM-4	0.33	0.06
SM-5	0.68	0.21
SM-6	0.89	0.24
SM-7	1.32	0.34
SM-8	1.72	0.37
SMB-8	2.40	0.64
SM-9	2.82	0.75
SM-9B	4.65	1.53
SM-10	5.01	1.72
SM-10B	10.15	2.90
SM-11	11.66	3.41
SM-12	18.30	5.56
SM-13	35.74	12.22
SM-14	61.55	21.70
SM-15	93.13	33.70

Model	Outer wheel	Inner Wheel
SMD-3	0.23	0.04
SMD-4	0.35	0.06
SMD-5	0.71	0.21
SMD-6	0.97	0.24
SMD-7	1.47	0.34
SMD-8	1.85	0.39
SMD-8B	2.61	0.67
SMD-9	3.06	0.78
SMD-9B	5.09	1.58
SMD-10	6.07	1.79
SMD-10B	11.30	3.00
SMD-11	12.97	3.55
SMD-12	20.33	5.86
SMD-13	39.82	12.75
SMD-14	68.04	22.56
SMD-15	102.70	35.07
SMD -16	162.00	54.10

Model	Outer wheel	Inner Wheel
SMDX-3	0.24	0.04
SMDX -4	0.36	0.06
SMDX -5	0.74	0.21
SMDX -6	1.04	0.24
SMDX -7	1.59	0.34
SMDX-8	1.96	0.39
SMDX-8B	2.76	0.67
SMDX -9	3.24	0.78
SMDX-9B	5.55	1.58
SMDX-10	7.04	1.79
SMDX-10B	12.30	3.00
SMDX -11	14.07	3.55
SMDX -12	21.93	5.86
SMDX -13	43.02	12.75
SMDX-14	73.14	22.56
SM DX-15	110.70	35.07

Model	* Outer wheel	Inner Wheel
SMP-1	0.11	0.02
2	0.15	0.03
3	0.28	0.04
4	0.37	0.05
5	0.76	0.12
6	0.96	0.25
7	1.43	0.34
8	1.88	0.47
9	2.89	0.65
10	5.37	2.11
11	11.98	3.43

* Values for maximum size of direct mounting pulley.

QUICK DECAY OF MOTOR CURRENT WITH FLUID COUPLING

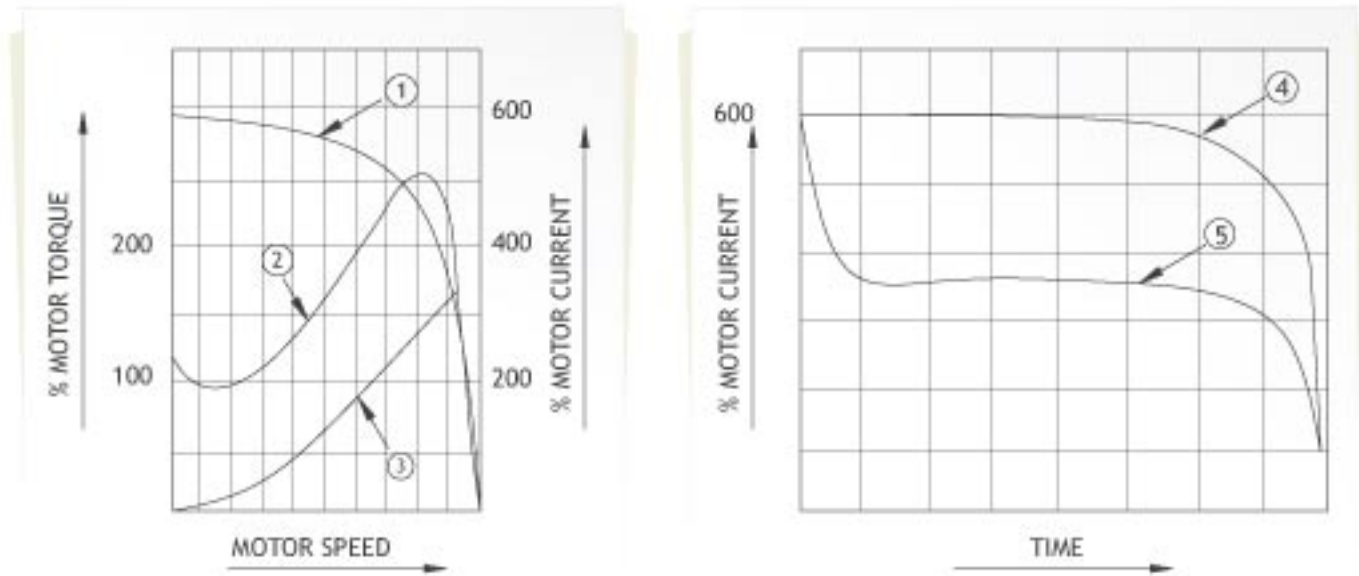

(TYPICAL)

- 1 MOTOR CURRENT
- 2 MOTOR TORQUE
- 3 FLUID COUPLING TORQUE AT 100% SLIP
- 4 MOTOR CURRENT WITHOUT FLUID COUPLING
- 5 MOTOR CURRENT WITH FLUID COUPLING

All Dimension in this catalogue are in mm unless specified otherwise.

Note: Due to continuous improvements the specifications may change without notice.

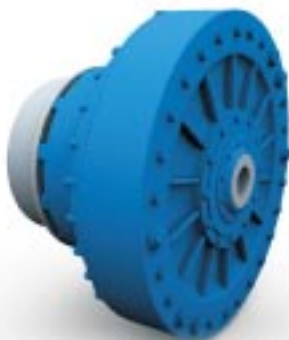

THERMAL PROTECTION

MTP SYSTEM

The operating temperature of MTP is as under:

MTP SETTING	FUSIBLE PLUG MELTING TEMPERATURE
< 110 °c	130 °c ± 5 °c
< 140 °c	160 °c ± 5 °c

Coupling should not be run more than 60 seconds after fusible has melted and oil is drained. Suitable guard must be provided so that the hot oil spray is restricted within the guard.

2. THERMAL TRIPPING ARRANGEMENT: MTP is a mechanical Thermal Switch. In order to avoid loss of operating fluid due to over heating of fluid coupling the mechanical Thermal Switch MTP can be added. However fusible plug with higher response temperature remains on the fluid coupling.

MTP consist of a plunger plug screwed on the fluid coupling body. A cam with limit switch are mounted on stationary base frame.

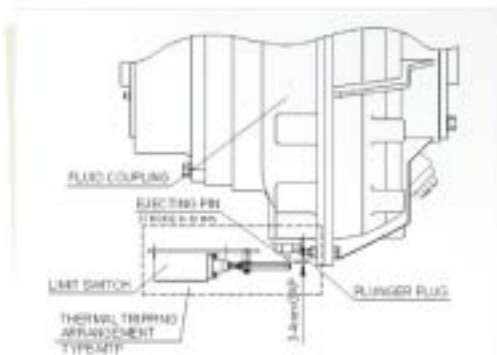

On exceeding the set temperature, the plunger plug ejects out a pin which hits the cam and operates the limit switch contact (make or break). Depending on the circuit selected the limit switch signal can be used to switch off the drive motor or activate audio/visual alarm.

The plunger plug has to be replaced after activation.

MTP system provides valuable safety and environment protection by avoiding spillage and loss of expensive operating fluid. Spillage of operating fluid can be expensive fire and accident hazard due to slippery floors and injury to workmen.

3. NON CONTACT ONLINE TEMPERATURE MONITOR WITH DISPLAY AND RELAY OUTPUT

TYPE- IRNC:

The IRNC operates on Infrared pyrometry and consists of stationery infrared non-contact pyrometer and a precision temperature controller. The non-contact infrared sensor is placed in any direction within 50 mm from body of fluid couplings.

The heat emitted by the body is sensor and gives a voltage output which is processed in the base unit and gives relay output on exceeding preset temperature values. Two set points are available which can be used for alarm and trip.

IRNC systems provide valuable safety and environment protection by avoiding spillage and loss of expensive operating fluid and fire hazardous hot oil spray.

Suggested temperature settings an IRNC system:

IRNC Setting		Fusible Plug Melting Temp
Set Point I	Set Point II	
< 95 °c	< 105 °c	130 °c ± 5 °c
< 125 °c	< 135 °c	160 °c ± 5 °c

Fusible plug must be used along with the system as a backup protection.





TONSON[®]

Factory 19 / 5 Lyn Parade PRESTONS NSW 2170

PH: 02 9607 4100 FAX: 02 9607 4200

www.tonson-motor.com.au

sales@samt.com.au

SAMT
Specialised Air Motors and Transmission

 **FLUIDOMAT**