

MV Electric Motors TEFC & TEAAC Type

LF & LT Series



Global Top Energy, Machinery & Plant Solution Provider



About HYOSUNG



Hyosung Power & Industrial Systems PG is a division under Hyosung which consists of seven performance groups (PGs). In addition to establishing itself as a world-class manufacturer of electrical equipments, green technology and industrial machineries, Hyosung is also the largest producer of tire cords and spandex in the global market and the second largest supplier of ATMs in the USA.

01 Our Business

Brief introduction of Hyosung Power & Industrial Systems

Hyosung Power & Industrial Systems Performance Group

Hyosung Power & Industrial Systems Performance Group, a comprehensive energy solution provider, boasts world-leading technology in the global power industry and has secured a competitive capability on par with that of top competitors in transformers, switchgears, motors, decelerators, industrial pumps, and wind energy business.

With globalization as one of our top priorities, we have achieved outstanding increase in sales over the past few years thanks to the enhancement in Hyosung's quality, technology, and brand recognition among overseas clients, which include North America, Europe, the Middle East, and Asia. We expect such robust performance, marked by an increasing number of orders from the overseas market, to continue in the future.

At the heart of our capability to grow as a comprehensive energy solution provider is our global organization structure. Hyosung Power & Industrial Systems Performance Group is divided into four business areas or performance units, depending on the types of flagship products: Power Systems Performance Unit, Industrial Machinery Performance Unit, Hyosung GoodSprings Performance Unit, and the Wind Energy Business Division.



Industrial Machinery Performance Unit

The Industrial Machinery Performance Unit plays an important role in the infrastructure industry around the globe and is specialized in manufacturing all types of motors, gear reducers, generators, green energy, and industrial machines.

With the ability to produce motors with up to 25,000kW, we possess an automated production line capable of manufacturing more than 40,000 motors every month.

In addition, we anticipate that our efforts in innovation among rotary machinery will make significant contributions towards creating energy profitability as well as greater efficiency. With the goal to serve as a world-leading provider of industrial machinery and plant engineering, we will continue to focus on innovative energy conservation technology, enhanced reliability of new products, and development of new technologies.



MV Electric Motors - TEFC & TEAAC Type

CONTENTS

02 Our Business 03 Sustainability / R&D 04 TEFC & TEAAC Motors / LF & LT Series 05 Why Hyosung Motors? 06 LF Series / General
07 LT Series / General 08 LF Series / Performance Data 12 LF Series / Dimension 14 LT Series / Performance Data 18 LT Series / Dimension
20 Optional Design & Test 21 Manufacturing Facilities 22 Global Sales Network



02 Sustainability

Our sustainability principles are the backbone of the way we design and manufacture products



Quality Assurance

Hyosung strives for excellence. We believe excellence can only be achieved through absolute quality and value for customers. In order to create quality products, we believe that all of the actions of every single employee must be focused in the highest level of quality. In order to achieve such levels, we have implemented a quality assurance policy and programs that make our philosophy into a reality.

Our Quality Assurance Policy was founded based on the management policy of the president and meets the demands of ISO 9001. As a globally active company, we are committed to comprehensive and quality management through three quality strategies: quality management system, customer-focused management system, and concentration on core competencies.

The comprehensive quality management system ensures that we completely comply with all compliances and applicable legislation, codes, and standards in addition to implementing efficient operation of our management resources to eliminate unnecessary waste.

Our customer-focused management system clarifies and simplifies our first priority which is customer satisfaction. All of our work is aimed to exceed customer needs and provide exceptional value through quality standards, flexibility, and innovation.

Finally, we concentrate on our core competencies for strict quality control and continual improvement which provides quality products and cost-saving to our clients via advancement in technical capacity and technological innovation.

We implement our policy via a Quality Management Team manages research laboratories, including the Measurement Standard Laboratory, the Chemical Analysis Laboratory and the Material Analysis Laboratory to maintain a strict control over quality.

Environment Protection Policy

Hyosung understands the impact of Hyosung's activities in the environment and works to protect the environment from pollution, manages the environmental impacts of Hyosung's products and technologies, and prevents future pollution and harmful effects in the environment by investing in environmentally-friendly products and solutions.

Based on this eco-philosophy of shared responsibility, Hyosung has implemented a comprehensive environmental protection program that aims to minimize our impact on the environment and conserve resources. Our environmental policy fulfils all requirements of the ISO 14001.

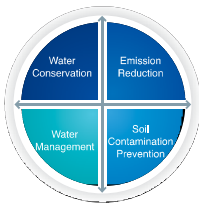

03 R&D

Inspiring innovation, creation and expertise

Hyosung R&D Center identifies innovation, creation, and expertise as core value, and concentrates on world class R&D activities in the 21st century with a philosophy aspiring after customer satisfaction, quality priority, and performance orientation. Hyosung pursues to be the world's best company in the field of heavy electrical machinery, industrial & electrical electronics engineering, and energy system. Ever since establishment in 1978, R&D Center had led the development of domestic technology. Along with the Anyang and Changwon labs, the group has endeavored to produce core technology and world-class products in the areas of heavy electrical machinery, energy system, electrical electronics engineering, and industrial automation system.

Research Areas

Hyosung R&D Center engages in the activities in the field of energy system, solution & service, applied electrical and electronic technology, basic core technology, technology of improved reliability, core components, and new materials.

Energy System

- Renewable energy (wind system, wind turbine, wind PCS, solar system, PV PCS, fuel cell, co-generation)
- Electric Vehicle (EV charger, EV motor)

Solution & Service

- Power facility diagnosis algorithm and system
- Power facility lifecycle evaluation system
- Service solution for remote diagnosis for prevention

Applied Electrical & Electronic Technology

- Power conversion system
- Flexible AC transmission system and high voltage direct current
- Power quality solution

Basic Core Technology

- Fortified technology in structural dynamics, electromagnetics, heat transfer analysis, etc.
- Skills for system simulation, analysis and evaluation
- Business support technology

Technology with Improved Reliability

- Test data analysis and testing facility
- Analysis of lifecycle and cause of error
- Reliability assessment (environment-friendliness, durability, long-term degradation, and more)

Core Components and New Materials

- Organic and inorganic insulation materials
- Silicon forming technology
- Intelligent sensor (facility diagnosis, CT, PT, VT, LA, and more)

TEFC & TEAAC Type / LF & LT Series

General Information

Hyosung's LF and LT Series MV motors are characterized by high efficiency and compactness.

Frame No.	315	355	400	450	500	560	630	710	
Type	3 phase squirrel cage induction motor								
Voltage & Frequency	6000V, 50Hz / 6600V, 60Hz								
	3300V and 6600V, 60Hz								
Rated power	LF Series	~ 2350kW							
	LT Series					~ 10200kW			
Ambient temperature	-20 ~ 40°C								
Insulation class & Temperature rise	F to B								
Altitude	1000m a.s.l								
Degree of protection	IP55								
Type of construction	IM 1001 (B3)								
Frame material	LF Series	Cast iron							
	LT Series					Welding			
Enclosure & method of cooling	LF Series	Totally enclosed fan cooled type - IC411							
	LT Series					Totally enclosed air-to-air cooled type - IC611			
Rotor bar type	LF Series	Aluminum die-casting							
	LT Series					Copper bar			
Starting method	Direct on line								
Bearings	LF Series	Anti-friction type (grease) or sleeve type (oil bath)							
	LT Series	Anti-friction type (grease) or sleeve type (oil bath)				Sleeve type with forced oil lubrication			
Direction of rotation	Clockwise or Counter-clockwise								
Vibration	≤2.8mm/s rms (acc. to EN 60034-14)								
Protection of windings	6 × PT100 Ω								
Protection of bearings	2 × PT100 Ω								
Anti-condensate heater	1EA (wired to the main terminal box as basic design)								
Standard	IEC								

LF and LT Series are for general use. They are suitable for constant operation of industrial machines such as pumps, compressors, fans and blowers, etc.

Protection degree of IP55 makes motors be able to operate in dusty environment.

Thanks to compact design and light weight, LF and LT series enable users to save more space for installation.

Why Hyosung Motors?



High Efficiency

Total loss has been reduced effectively by thorough airflow analysis and design optimization of mechanical structure.



Low Vibration & Noise Level

Vibration speed of the motors at no load shall not exceed 2.8mm/sec (r.m.s) according to IEC 60034-14. Low noise level has been achieved by optimizing mechanical structure of airflow inside the motor or the cooling unit.



User Convenience

LF & LT series motors will provide users with full satisfaction with their compactness and lightness, when installed or coupled to applications.

Especially for LF series, die-casting rotor is applied to reduce the weight.

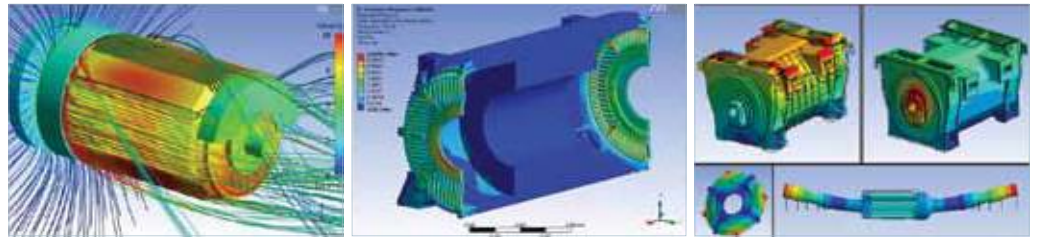

Reliable Bearings

LF series motors are equipped with anti-friction bearings with grease lubrication which are of SKF or equivalent.

For LT series, 2-pole & 4-pole motors up to 500 frame are available with self-lubricated sleeve bearings, whereas others are available with both anti-friction type and sleeve type with forced oil lubrication. Sleeve bearings are supplied by Renk or equivalent.

[Bearing No.]

LF Series

Frame No.	2P		4P~8P	
	DE Bearing	NDE Bearing	DE Bearing	NDE Bearing
280	6216	6216	6218	6216
315	6218	6218	6220	6218
355	6218	6218	6224	6220
400	Sleeve	Sleeve	6226	6224
450	Sleeve	Sleeve	NU1028+6028	NU1028
500	Sleeve	Sleeve	NU1030+6030	NU1030
560	-	-	NU1034+6034	NU1034

LT Series

Frame No.	2P		4P		6P		8P	
	DE Bearing	NDE Bearing	DE Bearing	NDE Bearing	DE Bearing	NDE Bearing	DE Bearing	NDE Bearing
450	Sleeve	Sleeve	NU1028+6028	NU1028	NU1030+6030	NU1030	NU1030+6030	NU1030
500	Sleeve	Sleeve	NU1032+6032	NU1032	NU1034+6034	NU1034	NU1034+6034	NU1034
560	Sleeve	Sleeve	Sleeve	Sleeve	NU1038+6038	NU1038	NU1038+6038	NU1038
630	Sleeve	Sleeve	Sleeve	Sleeve	NU1044+6044	NU1044	NU1044+6044	NU1044
710	Sleeve	Sleeve	Sleeve	Sleeve	Sleeve	Sleeve	Sleeve	Sleeve

LF Series / General

Totally Enclosed Fan Cooled, Squirrel Cage

Specifications

- **Enclosure** : Totally Enclosed
- **Rotor Type** : Squirrel Cage
- **Number of Pole** : 2 ~ 8 Poles
- **Voltage** : 2 ~ 7.2 kV
- **Output Range** : 120 ~ 2,350 kW
- **Frame Size** : 315 ~ 560 Frame
- **Degree of Protection** : IP55 (IEC60034-5)
- **Method of Cooling** : IC411 (IEC60034-6)
- **Insulation / Temp. Rise** : F / B
- **Type of Construction** : IM B3



Frame Assignment

50Hz, 6.0kV

Unit : kW

Model	Frame	Poles			
		2P	4P	6P	8P
LF	315	350	360	270	180
	315	500	560	420	300
	400	750	750	630	460
	450	1030	1000	800	670
	500	1420	1450	1250	940
	560	-	2200	1850	1400

60Hz, 6.6kV

Unit : kW

Model	Frame	Poles			
		2P	4P	6P	8P
LF	315	410	440	325	250
	315	560	640	510	360
	400	830	830	690	560
	450	1140	1100	900	770
	500	1560	1600	1360	1000
	560	-	2350	2000	1500

LT Series / General

Totally Enclosed Air to Air Cooled, Squirrel Cage

Specifications

- **Enclosure** : Totally Enclosed
- **Rotor Type** : Squirrel Cage
- **Number of Pole** : 2 ~ 8 Poles
- **Voltage** : 2 ~ 7.2 kV
- **Output Range** : 500 ~ 10,200 kW
- **Frame Size** : 450 ~ 710 Frame
- **Degree of Protection** : IP55 (IEC60034-5)
- **Method of Cooling** : IC611 (IEC60034-6)
- **Insulation / Temp. Rise** : F / B
- **Type of Construction** : IM B3

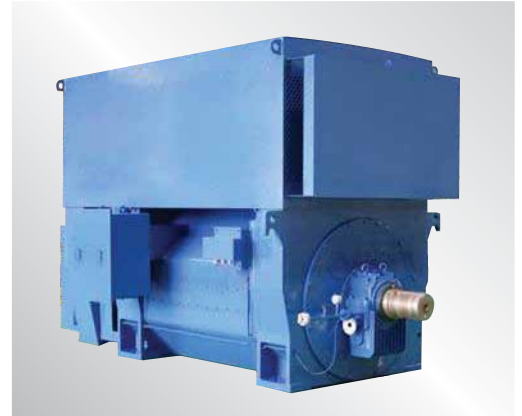

Frame Assignment

50Hz, 6.0kV

Unit : kW

Model	Frame	Poles			
		2P	4P	6P	8P
LT	450SB	1220	1240	900	630
	450LB	1550	1540	1200	880
	500SB	1900	1920	1600	1050
	500LB	2500	2450	1950	1400
	560SB	3000	3250	2550	1820
	560LB	3800	4000	3000	2200
	630SB	4500	4760	3850	2750
	630LB	6000	5800	4400	3200
	710SB	-	7100	5600	3900
710LB	-	8700	6400	4900	

60Hz, 6.6kV

Unit : kW

Model	Frame	Poles			
		2P	4P	6P	8P
LT	450SB	1430	1450	1100	840
	450LB	1820	1850	1430	1030
	500SB	2300	2300	1920	1400
	500LB	3000	2900	2300	1700
	560SB	3500	3700	3050	2200
	560LB	4200	4500	3600	2650
	630SB	4900	5500	4550	3300
	630LB	6300	6700	5200	3800
	710SB	-	8400	6400	4900
	710LB	-	10200	7500	6000

LF Series / Performance Data

LF Series : 50Hz, 6.0kV

Rated power	Frame	Speed	Rated current	Efficiency	Power factor	Torque	Break down torque	Locked -rotor torque	Locked -rotor current	Rotor Inertia	Mean sound level
P _N		n _N	I _N	100% load	100% load	T _N	T _{max} / T _N	T _s / I _N	I _s / I _N	J	-
kW		rpm	A	%	cos φ [%]	Nm	[%]	[%]	[%]	kgm	dB(A)
6.0kV, 50Hz											
2-Pole											
200	315	2975	23.3	95.0	86.8	642	230	90	680	5	80
250	315	2975	29.0	95.1	87.1	803	230	90	680	6	80
300	315	2975	34.8	95.3	87.1	963	230	90	680	6	80
350	315	2976	40.4	95.3	87.5	1123	230	90	680	6	80
400	355	2979	44.4	95.7	90.5	1282	230	100	680	7	80
450	355	2979	49.9	96.2	90.2	1443	230	100	680	9	80
500	355	2979	55.1	96.2	90.8	1603	230	100	680	12	80
560	400	2978	61.8	96.4	90.5	1796	230	90	680	22	82
620	400	2978	68.3	96.4	90.6	1988	230	90	680	22	82
670	400	2978	73.6	96.5	90.8	2149	230	90	680	23	82
750	400	2979	82.2	96.5	91.0	2404	230	100	680	24	82
820	450	2979	89.9	96.7	90.8	2629	230	85	650	39	83
880	450	2979	96.4	96.8	90.7	2821	230	85	650	39	83
960	450	2980	105.3	96.7	90.7	3077	230	85	650	43	83
1030	450	2980	112.5	96.8	91.0	3301	230	80	650	43	83
1100	500	2980	120.2	96.8	91.0	3525	230	80	650	75	85
1250	500	2980	136.5	96.8	91.0	4006	230	75	650	75	85
1350	500	2981	147.0	96.9	91.2	4325	230	75	650	81	85
1420	500	2981	154.4	96.9	91.3	4549	230	75	650	81	85
4-Pole											
190	315	1482	22.7	95.1	84.6	1224	230	100	650	4	80
240	315	1485	28.5	95.2	85.1	1543	230	100	650	5	80
280	315	1485	33.3	95.3	85.0	1801	230	100	650	5	80
320	315	1485	37.5	95.4	86.0	2058	230	100	650	7	80
360	315	1485	42.2	95.5	86.0	2315	230	100	650	7	80
400	355	1484	45.8	95.7	87.8	2574	230	100	650	11	80
450	355	1485	51.5	95.6	87.9	2894	230	100	650	11	80
500	355	1485	57.0	95.9	88.0	3215	230	100	650	12	80
560	355	1485	63.8	96.0	88.0	3601	230	100	650	12	81
620	400	1486	70.8	96.2	87.6	3985	230	100	650	20	81
680	400	1486	77.6	96.4	87.5	4370	230	100	650	21	81
750	400	1487	85.3	96.4	87.8	4817	230	100	650	21	81
820	450	1487	93.3	96.5	87.6	5266	230	100	650	37	81
920	450	1487	104.6	96.6	87.6	5909	230	100	650	38	81
1000	450	1487	113.2	96.6	88.0	6422	230	100	650	39	81
1120	500	1486	126.8	96.7	87.9	7198	230	100	650	59	83
1250	500	1486	141.3	96.7	88.0	8033	220	100	650	67	83
1350	500	1488	152.1	96.7	88.3	8664	220	100	650	68	83
1450	500	1488	163.2	96.6	88.5	9306	220	100	650	69	83
1600	560	1490	179.7	96.6	88.7	10255	220	100	650	108	85
1800	560	1490	201.3	96.7	89.0	11537	220	100	650	111	85
2000	560	1490	222.6	96.8	89.3	12819	220	100	650	115	85
2200	560	1490	222.2	96.8	98.4	14101	220	100	650	122	85

Rated power	Frame	Speed	Rated current	Efficiency	Power factor	Torque	Break down torque	Locked -rotor torque	Locked -rotor current	Rotor Inertia	Mean sound level
P _N		n _N	I _N	100% load	100% load	T _N	T _{max} / T _N	T _s / I _N	I _s / I _N	J	-
kW		rpm	A	%	cos φ[%]	Nm	[%]	[%]	[%]	kgm	dB(A)
6.0kV, 50Hz											
6-Pole											
160	315	985	19.8	94.8	82.0	1551	210	100	650	8	80
190	315	985	23.5	94.9	82.0	1842	210	100	650	8	80
220	315	986	27.1	95.0	82.1	2131	210	100	650	8	80
250	315	986	30.9	95.0	82.0	2421	210	100	650	9	80
270	315	986	33.3	95.1	82.1	2615	210	100	650	9	80
300	355	988	37.9	95.2	80.0	2900	210	100	650	15	80
350	355	988	44.1	95.3	80.1	3383	210	100	650	16	80
390	355	989	49.2	95.4	80.0	3766	210	100	650	18	80
420	355	989	52.6	95.6	80.4	4056	210	100	650	18	80
490	400	989	59.4	95.8	82.9	4732	200	100	650	28	80
550	400	989	66.4	96.0	83.0	5311	200	100	650	32	80
630	400	989	76.1	96.2	82.8	6083	200	100	650	32	81
700	450	989	82.5	96.3	84.8	6759	200	90	650	46	81
800	450	990	94.5	96.4	84.5	7717	200	90	650	51	81
860	500	990	98.2	96.3	87.5	8296	200	90	650	76	82
950	500	990	108.5	96.4	87.4	9164	200	90	650	81	82
1100	500	990	125.2	96.5	87.6	10611	200	90	650	87	82
1250	500	991	142.3	96.5	87.6	12046	200	90	650	99	83
1350	560	992	154.2	96.6	87.2	12996	200	90	620	138	83
1500	560	992	170.6	96.7	87.5	14441	200	90	620	143	83
1700	560	993	193.8	96.7	87.3	16349	200	90	620	154	85
1850	560	993	210.2	96.8	87.5	17792	200	90	620	161	85
8-Pole											
110	315	740	14.5	93.9	77.5	1420	210	100	620	8	79
150	315	740	19.8	93.9	77.5	1936	210	100	620	9	79
180	315	741	23.6	94.1	77.9	2320	210	100	620	11	79
210	355	742	26.7	95.2	79.5	2703	210	100	620	20	79
260	355	742	32.9	95.3	79.8	3346	210	100	620	21	79
300	355	742	37.5	95.5	80.7	3861	210	100	620	22	79
340	400	743	42.2	95.5	81.2	4370	210	100	620	34	79
380	400	743	46.9	95.6	81.5	4884	210	100	620	35	79
430	400	744	53.0	95.6	81.7	5519	210	100	620	35	79
460	400	744	56.4	95.7	82.0	5905	210	100	620	36	80
520	450	743	64.1	95.8	81.5	6684	210	100	620	58	80
600	450	743	73.9	95.8	81.5	7712	210	100	620	63	80
670	450	743	82.0	95.9	82.0	8612	210	100	620	63	82
750	500	744	91.5	96.0	82.2	9627	200	90	600	90	82
850	500	744	103.5	96.1	82.2	10911	200	90	600	93	82
940	500	744	114.1	96.1	82.5	12066	200	90	600	100	82
1050	560	744	127.0	96.3	82.6	13478	200	90	600	152	84
1150	560	744	139.0	96.4	82.6	14761	200	90	600	165	84
1280	560	745	154.5	96.5	82.6	16408	200	90	580	168	84
1400	560	745	168.6	96.5	82.8	17946	200	90	580	176	84

* Note - F/B, Ambient temperature 40°C
 - Above technical data are only design values and shall be guaranteed with tolerance of applicable standard. (IEC tolerance is applied.)
 - Sound pressure level is at no load condition.

LF Series / Performance Data

LF Series : 60Hz, 6.6kV

Rated power	Frame	Speed	Rated current	Efficiency	Power factor	Torque	Break down torque	Locked -rotor torque	Locked -rotor current	Rotor Inertia	Mean sound level
P _N		n _N	I _N	100% load	100% load	T _N	T _{max} / T _N	T _s / I _N	I _s / I _N	J	-
kW		rpm	A	%	cos φ[%]	Nm	[%]	[%]	[%]	kgm	dB(A)
6.6kV, 60Hz											
2-Pole											
240	315	3572	25.5	95.2	86.5	642	230	90	680	4	81
280	315	3575	29.6	95.2	86.8	748	230	90	680	4	81
320	315	3575	33.8	95.2	87.0	855	230	90	680	5	81
360	315	3575	37.9	95.4	87.1	962	230	90	680	5	81
410	315	3575	43.0	95.3	87.5	1095	230	90	680	5	81
450	355	3576	46.4	96.1	88.2	1202	230	90	680	11	82
500	355	3579	51.7	96.2	88.0	1334	230	90	680	11	82
560	355	3579	57.7	96.2	88.3	1494	230	90	680	12	82
630	400	3581	64.1	96.4	89.2	1680	230	90	680	21	83
700	400	3581	70.9	96.4	89.6	1867	230	90	680	21	83
750	400	3583	75.6	96.5	89.9	1999	230	90	680	23	83
830	400	3583	83.3	96.7	90.1	2212	230	80	650	23	83
900	450	3582	89.8	96.8	90.6	2399	230	80	650	39	85
950	450	3582	94.9	96.8	90.5	2533	230	80	650	39	85
1060	450	3583	106.0	96.7	90.5	2825	230	80	650	43	85
1140	450	3582	114.0	96.7	90.5	3039	230	75	650	43	85
1200	500	3582	119.7	96.8	90.6	3199	230	75	650	75	88
1350	500	3581	134.8	96.8	90.5	3600	230	75	650	75	88
1450	500	3582	144.6	96.7	90.7	3866	230	70	650	81	88
1560	500	3582	154.9	96.8	91.0	4159	230	70	650	81	88
4-Pole											
230	315	1777	25.2	95.0	84.2	1236	230	100	650	3	81
270	315	1777	29.5	95.1	84.2	1451	230	100	650	3	81
310	315	1777	33.8	95.2	84.3	1666	230	100	650	4	81
350	315	1778	38.0	95.4	84.5	1880	230	100	650	4	81
390	315	1778	42.3	95.7	84.3	2095	230	100	650	5	81
440	315	1778	47.7	95.7	84.3	2363	230	100	650	5	81
460	355	1785	48.7	95.8	86.2	2461	230	100	650	10	81
520	355	1785	55.0	95.9	86.2	2782	230	100	650	10	81
580	355	1785	61.1	96.0	86.5	3103	230	100	650	11	82
640	355	1787	67.4	96.0	86.5	3420	230	100	650	12	82
700	400	1787	73.1	96.3	87.0	3741	230	100	650	18	83
780	400	1787	81.4	96.4	87.0	4168	230	100	650	20	83
830	400	1788	86.5	96.4	87.1	4433	230	100	650	20	83
950	450	1788	98.9	96.5	87.1	5074	230	100	650	36	83
1100	450	1790	114.8	96.6	86.8	5869	230	100	650	38	85
1200	500	1788	124.1	96.8	87.4	6409	230	100	650	56	85
1350	500	1788	139.4	96.7	87.6	7211	230	100	650	66	85
1500	500	1788	154.2	96.7	88.0	8012	230	100	650	66	85
1600	500	1788	164.4	96.5	88.2	8546	230	100	650	68	85
1730	560	1790	176.6	96.6	88.7	9230	230	100	650	105	87
1960	560	1790	199.7	96.8	88.7	10457	230	100	650	110	87
2190	560	1790	222.4	96.8	89.0	11684	230	100	650	114	87
2350	560	1790	238.6	96.8	89.0	12538	230	100	650	122	87

Rated power	Frame	Speed	Rated current	Efficiency	Power factor	Torque	Break down torque	Locked -rotor torque	Locked -rotor current	Rotor Inertia	Mean sound level
P _N		n _N	I _N	100% load	100% load	T _N	T _{max} / T _N	T _s / I _N	I _s / I _N	J	-
kW		rpm	A	%	cos φ[%]	Nm	[%]	[%]	[%]	kgm	dB(A)
6.6kV, 60Hz											
6-Pole											
190	315	1183	21.4	94.7	82.0	1534	210	100	650	7	80
220	315	1185	24.7	94.9	82.0	1773	210	100	650	7	80
250	315	1185	28.0	95.0	82.1	2015	210	100	650	8	80
280	315	1185	31.4	95.0	82.0	2257	210	100	650	8	80
325	315	1187	36.5	94.9	82.1	2615	210	100	650	9	80
380	355	1186	43.6	95.2	80.0	3060	210	100	650	14	82
430	355	1187	49.3	95.3	80.1	3460	210	100	650	16	82
480	355	1188	55.0	95.5	80.0	3859	210	100	650	17	82
510	355	1190	58.2	95.4	80.4	4093	210	100	650	18	82
550	400	1190	60.5	95.9	82.9	4414	210	100	650	27	82
620	400	1189	68.1	96.0	83.0	4980	210	100	650	31	82
690	400	1190	76.0	95.9	82.8	5537	210	100	650	30	82
770	450	1192	82.5	96.3	84.8	6169	210	100	650	45	83
900	450	1192	96.8	96.3	84.5	7211	210	90	650	51	83
950	500	1192	98.6	96.3	87.5	7611	200	90	650	74	85
1060	500	1193	110.1	96.4	87.4	8485	200	90	650	80	85
1190	500	1193	123.3	96.4	87.6	9526	200	90	650	83	85
1360	500	1193	140.7	96.5	87.6	10887	200	90	650	99	85
1460	560	1192	151.6	96.6	87.2	11697	200	90	650	137	85
1660	560	1193	171.8	96.6	87.5	13288	200	90	650	143	85
1860	560	1193	192.7	96.7	87.3	14889	200	90	650	152	86
2000	560	1193	206.8	96.7	87.5	16010	200	90	650	160	86
8-Pole											
120	315	890	14.5	93.8	77.1	1288	210	100	600	7	80
150	315	890	18.1	93.9	77.3	1610	210	100	600	8	80
200	315	891	23.8	94.2	78.0	2144	210	100	600	10	80
250	315	891	29.6	94.2	78.4	2680	210	100	600	11	80
270	355	890	30.8	95.4	80.3	2897	210	100	600	19	80
300	355	890	34.0	95.5	80.8	3219	210	100	600	21	80
360	355	890	40.6	95.6	81.1	3863	210	100	600	22	80
410	400	890	45.9	95.4	81.9	4399	210	100	600	34	80
460	400	890	51.4	95.3	82.2	4936	210	100	600	32	80
510	400	891	57.2	95.4	81.8	5466	210	100	600	34	80
560	400	892	62.1	95.4	82.7	5996	210	100	600	34	80
600	450	893	67.5	95.7	81.3	6417	200	90	600	55	82
680	450	893	76.3	95.8	81.4	7272	200	90	600	62	82
770	450	894	85.5	95.7	82.3	8227	200	90	600	62	82
870	500	895	96.3	96.0	82.3	9279	200	90	600	89	85
1000	500	895	110.9	96.1	82.1	10670	200	90	600	100	85
1200	560	895	131.0	96.4	83.1	12804	200	90	600	149	85
1350	560	895	148.3	96.5	82.5	14405	200	90	600	168	85
1500	560	895	163.6	96.5	83.1	16006	200	90	600	177	85

* Note - F/B, Ambient temperature 40°C
 - Above technical data are only design values and shall be guaranteed with tolerance of applicable standard. (IEC tolerance is applied.)
 - Sound pressure level is at no load condition.

LF Series / Dimension

Outline Dimension Drawing

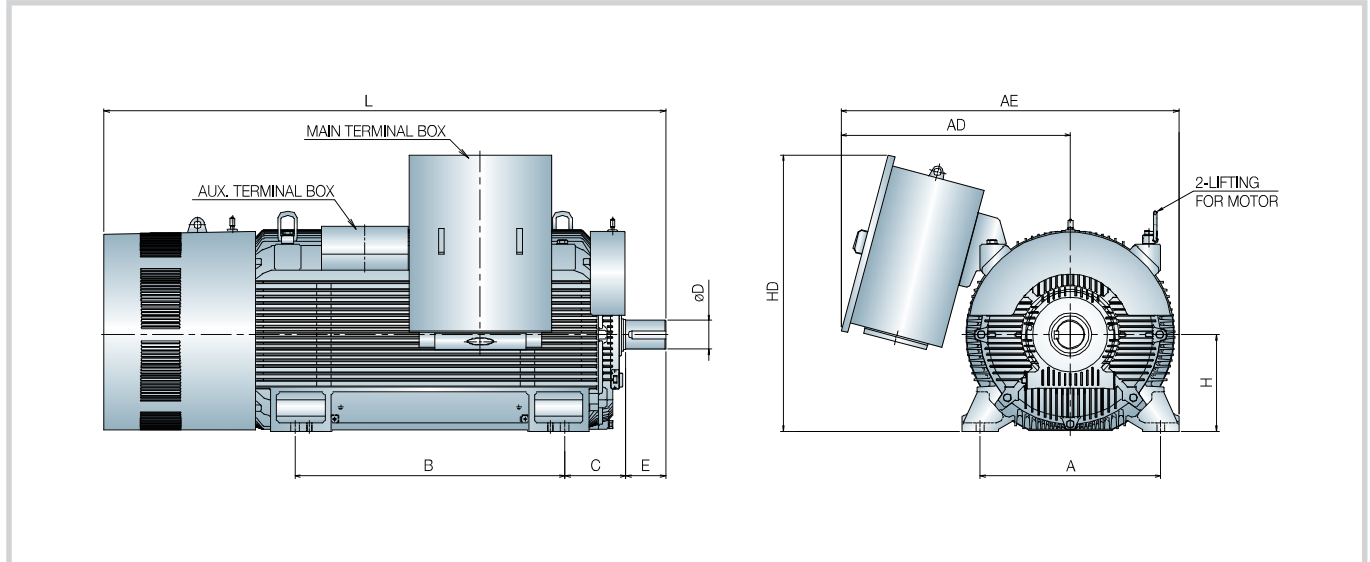

Motor type	Weight kg	Dimensions									
		A mm	AD mm	AE mm	B mm	C mm	D mm	E mm	H mm	HD mm	L mm
2P											
315	2250	610	900	1265	900	200	70	105	315	1010	2100
355	2800	686	945	1360	1000	224	75	105	355	1100	2250
4P											
315	2300	610	900	1265	900	200	90	130	315	1010	2000
355	3000	686	945	1350	1000	224	100	165	355	1100	2250
400	4050	750	960	1410	1120	254	120	165	400	1150	2460
450	5550	850	1005	1520	1250	280	130	200	450	1250	2710
500	7050	950	1085	1650	1320	315	140	200	500	1350	3000
560	9950	1060	1110	1745	1400	335	160	240	560	1450	3250
6P											
315	2300	610	900	1265	900	200	90	130	315	1010	2000
355	3000	686	945	1350	1000	224	100	165	355	1100	2250
400	4050	750	960	1410	1120	254	120	165	400	1150	2460
450	5550	850	1005	1520	1250	280	130	200	450	1250	2710
500	7050	950	1085	1650	1320	315	140	200	500	1350	3000
560	9950	1060	1110	1745	1400	335	160	240	560	1450	3250
8P											
315	2300	610	900	1265	900	200	90	130	315	1010	2000
355	3000	686	945	1350	1000	224	100	165	355	1100	2250
400	4050	750	960	1410	1120	254	120	165	400	1150	2460
450	5550	850	1005	1520	1250	280	130	200	450	1250	2710
500	7050	950	1085	1650	1320	315	140	200	500	1350	3000
560	9950	1060	1110	1745	1400	335	160	240	560	1450	3250

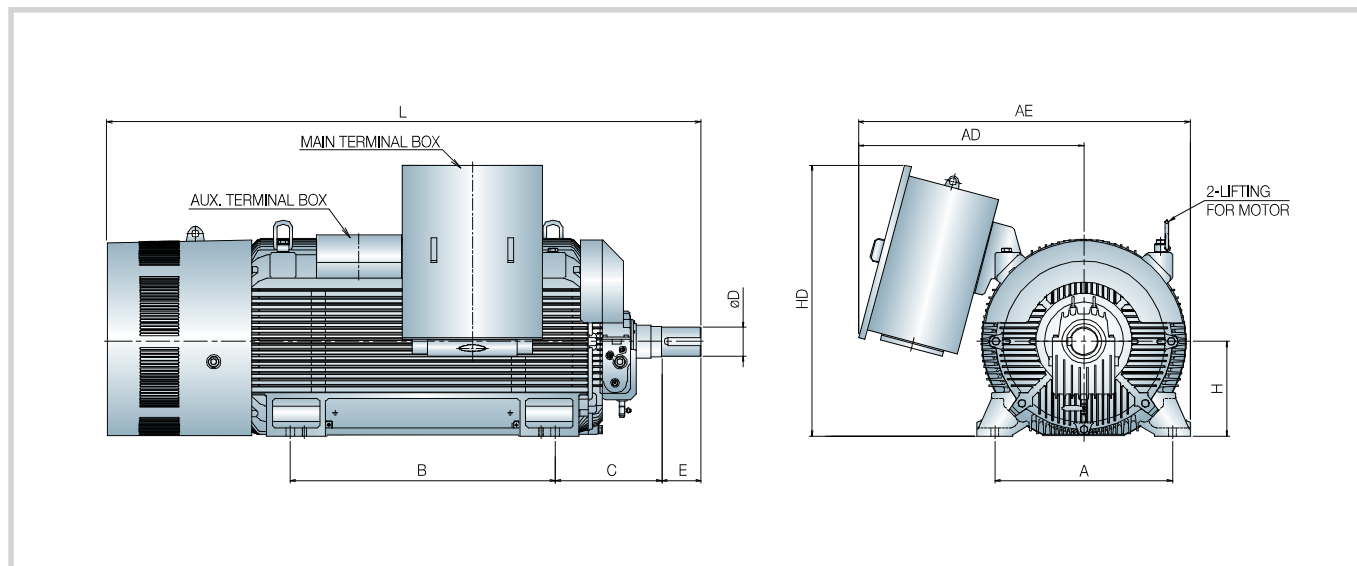

Motor type	Weight kg	Dimensions									
		A mm	AD mm	AE mm	B mm	C mm	D mm	E mm	H mm	HD mm	L mm
2P											
315	2350	610	900	1265	900	375	70	105	315	1010	2300
355	2900	686	945	1360	1000	400	75	105	355	1100	2500
400	3850	750	960	1410	1120	425	85	130	400	1150	2800
450	5450	850	1005	1520	1250	475	95	130	450	1250	3200
500	6950	950	1085	1650	1320	500	110	165	500	1350	3280
560											
4P											
315	2400	610	900	1265	900	375	90	130	315	1010	2200
355	3100	686	945	1360	1000	400	100	165	355	1100	2500
400	4150	750	960	1410	1120	450	120	165	400	1150	2650
450	5650	850	1005	1520	1250	475	130	200	450	1250	2900
500	7250	950	1085	1650	1320	500	140	200	500	1350	3290
560	10300	1060	1110	1745	1400	560	160	240	560	1450	3400
6P											
315	2400	610	900	1265	900	375	90	130	315	1010	2200
355	3100	686	945	1360	1000	400	100	165	355	1100	2500
400	4150	750	960	1410	1120	450	120	165	400	1150	2650
450	5650	850	1005	1520	1250	475	130	200	450	1250	2900
500	7250	950	1085	1650	1320	500	140	200	500	1350	3290
560	10300	1060	1110	1745	1400	560	160	240	560	1450	3400
8P											
315	2400	610	900	1265	900	375	90	130	315	1010	2200
355	3100	686	945	1360	1000	400	100	165	355	1100	2500
400	4150	750	960	1410	1120	450	120	165	400	1150	2650
450	5650	850	1005	1520	1250	475	130	200	450	1250	2900
500	7250	950	1085	1650	1320	500	140	200	500	1350	3290
560	10300	1060	1110	1745	1400	560	160	240	560	1450	3400

LT Series / Performance Data

LT Series : 50Hz, 6.0kV

Rated power	Frame	Speed	Rated current	Efficiency	Power factor	Torque	Break down torque	Locked -rotor torque	Locked -rotor current	Rotor Inertia
P _N		n _N	I _N	100% load	100% load	T _N	T _{max} / T _N	T _s / I _N	I _s / I _N	J
kW		rpm	A	%	cos φ [%]	Nm	[%]	[%]	[%]	kgm
6.0kV, 50Hz										
2-Pole										
1060	LT-450SB	2973	122.1	94.9	88.0	3405	230	100	650	15
1220	LT-450SB	2975	139.7	95.5	88.0	3916	230	100	680	17
1410	LT-450LB	2975	161.6	95.4	88.0	4526	230	100	680	19
1550	LT-450LB	2975	177.5	95.5	88.0	4976	230	100	650	21
1700	LT-500SB	2979	194.9	95.5	87.9	5450	220	100	650	29
1900	LT-500SB	2978	215.1	95.4	89.1	6093	220	100	680	31
2250	LT-500LB	2979	254.2	95.7	89.0	7213	210	100	650	33
2500	LT-500LB	2980	281.9	95.9	89.0	8012	210	100	650	36
2750	LT-560SB	2978	315.0	95.9	87.6	8819	210	80	600	52
3000	LT-560SB	2978	341.7	96.1	87.9	9621	210	80	630	56
3400	LT-560LB	2979	381.7	96.1	89.2	10900	210	80	650	61
3800	LT-560LB	2980	423.3	96.3	89.7	12178	210	80	630	65
4000	LT-630SB	2979	449.6	96.3	88.9	12823	200	90	650	81
4500	LT-630SB	2981	500.2	96.4	89.8	14416	200	90	650	89
5000	LT-630LB	2982	551.6	96.6	90.3	16013	200	85	680	97
5400	LT-630LB	2982	595.0	96.6	90.4	17294	200	85	680	103
6000	LT-630LB	2983	657.6	96.8	90.7	19209	200	85	680	108
4-Pole										
1120	LT-450SB	1482	129.5	95.2	87.4	7217	220	110	700	35
1240	LT-450SB	1484	142.3	95.4	87.9	7980	220	110	700	38
1400	LT-450LB	1485	159.9	95.6	88.1	9003	220	110	700	40
1540	LT-450LB	1484	175.8	95.7	88.1	9910	220	110	700	42
1750	LT-500SB	1485	200.2	95.9	87.7	11254	210	100	630	63
1920	LT-500SB	1485	219.4	96.0	87.7	12347	220	110	650	67
2250	LT-500LB	1486	256.3	96.1	87.9	14460	210	110	630	71
2450	LT-500LB	1486	278.2	96.2	88.1	15745	210	100	630	74
2950	LT-560SB	1486	343.1	96.2	86.0	18959	200	85	600	116
3250	LT-560SB	1487	369.5	96.3	87.9	20873	200	85	600	121
3550	LT-560LB	1487	403.5	96.2	88.0	22799	200	90	600	126
3800	LT-560LB	1488	430.5	96.4	88.1	24388	200	85	600	131
4000	LT-560LB	1488	452.7	96.5	88.1	25672	200	85	600	138
4400	LT-630SB	1488	498.5	96.4	88.1	28239	200	80	600	202
4760	LT-630SB	1488	538.1	96.5	88.2	30550	200	80	600	214
5200	LT-630LB	1489	586.0	96.6	88.4	33351	200	80	600	222
5500	LT-630LB	1489	620.5	96.6	88.3	35275	200	85	600	236
5800	LT-630LB	1490	651.5	96.8	88.5	37174	200	85	600	246
6400	LT-710SB	1491	717.3	96.9	88.6	40993	200	85	600	389
7100	LT-710SB	1491	793.2	97.0	88.8	45476	200	85	600	411
7850	LT-710LB	1491	877.9	97.0	88.7	50280	200	80	600	426
8700	LT-710LB	1492	970.8	97.0	88.9	55687	200	85	600	440

Rated power	Frame	Speed	Rated current	Efficiency	Power factor	Torque	Break down torque	Locked -rotor torque	Locked -rotor current	Rotor Inertia
P _N		n _N	I _N	100% load	100% load	T _N	T _{max} / T _N	T _s / I _N	I _s / I _N	J
kW		rpm	A	%	cos φ [%]	Nm	[%]	[%]	[%]	kgm
6.0kV, 50Hz										
6-Pole										
800	LT-450SB	987	96.9	95.0	83.6	7741	210	90	600	42
900	LT-450SB	987	107.9	95.0	84.5	8708	200	90	600	46
1050	LT-450LB	988	124.7	95.2	85.1	10149	200	90	600	51
1200	LT-450LB	988	140.7	95.4	86.0	11599	200	100	650	55
1400	LT-500SB	989	165.6	95.7	85.0	13519	200	90	600	88
1600	LT-500SB	988	186.3	96.0	86.1	15466	200	90	580	95
1800	LT-500LB	990	207.0	96.2	87.0	17364	200	85	580	101
1950	LT-500LB	990	223.9	96.2	87.1	18811	200	85	550	106
2250	LT-560SB	990	266.6	96.1	84.5	21705	200	80	550	146
2550	LT-560SB	991	301.5	96.3	84.5	24574	200	80	550	159
2740	LT-560LB	991	323.3	96.4	84.6	26405	200	80	550	173
3000	LT-560LB	991	351.9	96.4	85.1	28910	200	80	550	180
3550	LT-630SB	990	402.7	96.4	88.0	34245	200	90	600	289
3850	LT-630SB	991	437.2	96.5	87.8	37101	200	90	600	305
4100	LT-630LB	991	464.6	96.5	88.0	39511	200	90	600	322
4400	LT-630LB	992	497.4	96.5	88.2	42359	200	90	620	349
4800	LT-710SB	992	549.6	96.6	87.0	46210	200	85	580	475
5150	LT-710SB	993	589.0	96.7	87.0	49529	200	85	580	493
5600	LT-710SB	992	636.9	96.7	87.5	53911	200	85	580	521
6000	LT-710LB	993	678.5	96.7	88.0	57704	200	80	600	554
6400	LT-710LB	993	721.5	97.0	88.0	61551	200	80	600	570
8-Pole										
630	LT-450SB	740	77.6	95.3	82.0	8130	200	100	620	60
750	LT-450LB	740	92.0	95.4	82.2	9679	200	100	600	65
880	LT-450LB	740	108.0	95.4	82.2	11357	200	100	600	70
1050	LT-500SB	740	124.2	95.5	85.2	13551	200	100	600	121
1200	LT-500LB	742	140.8	95.8	85.6	15445	200	100	620	136
1400	LT-500LB	742	164.1	95.9	85.6	18019	200	100	600	142
1600	LT-560SB	742	193.4	95.9	83.0	20593	200	100	620	178
1820	LT-560SB	742	218.5	96.0	83.5	23425	200	90	600	199
2000	LT-560LB	743	240.1	96.0	83.5	25707	200	90	600	212
2200	LT-560LB	743	262.0	96.2	84.0	28277	200	90	600	225
2500	LT-630SB	743	301.6	96.1	83.0	32133	200	90	600	331
2750	LT-630SB	743	330.6	96.1	83.3	35347	200	90	600	359
2950	LT-630LB	743	354.3	96.3	83.2	37917	200	90	580	375
3200	LT-630LB	744	384.3	96.3	83.2	41075	200	90	580	384
3500	LT-710SB	744	413.9	96.3	84.5	44926	200	90	550	556
3900	LT-710SB	744	458.6	96.5	84.8	50060	200	90	580	590
4350	LT-710LB	744	509.8	96.6	85.0	55837	200	90	600	618
4900	LT-710LB	745	573.6	96.7	85.0	62812	200	90	600	641

* Note - F/B, Ambient temperature 40°C
 - Above technical data are only design values and shall be guaranteed with tolerance of applicable standard. (IEC tolerance is applied.)
 - Standard sound pressure level is 85dB(A) at no load.

LT Series / Performance Data

LT Series : 60Hz, 6.6kV

Rated power	Frame	Speed	Rated current	Efficiency	Power factor	Torque	Break down torque	Locked -rotor torque	Locked -rotor current	Rotor Inertia
P _N		n _N	I _N	100% load	100% load	T _N	T _{max} / T _N	T _s / I _N	I _s / I _N	J
kW		rpm	A	%	cos φ [%]	Nm	[%]	[%]	[%]	kgm
6.6kV, 60Hz										
2-Pole										
1250	LT-450SB	3568	130.7	95.1	88.0	3346	220	100	680	14
1430	LT-450SB	3568	148.5	95.2	88.5	3827	230	100	680	16
1600	LT-450LB	3568	165.2	95.2	89.0	4283	230	100	680	18
1820	LT-450LB	3570	185.4	95.4	90.0	4869	230	100	650	19
2000	LT-500SB	3574	205.0	95.9	89.0	5344	210	100	600	27
2300	LT-500SB	3574	234.9	95.8	89.4	6146	230	100	630	29
2650	LT-500LB	3573	270.4	95.9	89.4	7083	220	100	650	32
3000	LT-500LB	3574	303.7	96.0	90.0	8016	230	100	650	35
3250	LT-560SB	3573	330.5	96.0	89.6	8687	210	90	680	51
3500	LT-560SB	3573	355.2	96.0	89.8	9355	230	85	680	55
3750	LT-560LB	3573	379.3	96.1	90.0	10023	220	85	650	59
4000	LT-560LB	3574	401.5	96.3	90.5	10688	220	85	650	62
4200	LT-560LB	3575	419.3	96.4	90.9	11220	230	85	680	64
4500	LT-630SB	3575	449.2	96.3	91.0	12021	200	95	600	86
4900	LT-630SB	3576	485.4	96.5	91.5	13086	200	95	580	90
5500	LT-630LB	3576	543.2	96.7	91.6	14688	200	85	680	96
6000	LT-630LB	3576	593.2	96.6	91.6	16023	200	85	680	101
6300	LT-630LB	3578	620.1	96.7	91.9	16815	200	90	700	104
4-Pole										
1320	LT-450SB	1782	144.1	95.2	84.2	7074	230	100	650	35
1450	LT-450SB	1783	158.1	95.3	84.2	7766	230	100	650	37
1600	LT-450LB	1782	168.7	95.6	86.8	8575	220	100	650	40
1850	LT-450LB	1783	193.1	95.8	87.5	9909	220	100	650	43
2100	LT-500SB	1783	219.4	95.7	87.5	11248	220	100	650	62
2300	LT-500SB	1784	239.0	96.0	87.7	12312	210	100	600	66
2600	LT-500LB	1785	270.8	96.0	87.5	13910	210	100	620	72
2900	LT-500LB	1785	301.4	96.2	87.5	15515	210	100	600	77
3250	LT-560SB	1785	339.6	96.0	87.2	17388	210	90	600	107
3500	LT-560SB	1785	365.4	96.2	87.1	18725	210	85	600	110
3700	LT-560SB	1785	383.2	96.2	87.8	19796	210	75	580	114
4000	LT-560LB	1785	412.0	96.3	88.2	21401	210	80	600	126
4250	LT-560LB	1785	436.2	96.3	88.5	22738	200	80	600	131
4500	LT-560LB	1786	458.3	96.5	89.0	24062	200	75	550	137
5000	LT-630SB	1786	519.1	96.3	87.5	26736	200	85	620	199
5500	LT-630SB	1786	569.0	96.3	87.8	29409	200	80	600	208
6000	LT-630LB	1788	610.5	96.7	88.9	32047	200	80	620	230
6700	LT-630LB	1791	669.8	96.9	90.3	35726	200	70	550	242
7000	LT-710SB	1790	701.4	96.9	90.1	37346	200	80	600	357
8400	LT-710SB	1791	832.5	97.0	91.0	44791	200	70	550	377
9000	LT-710LB	1790	890.9	97.0	91.1	48017	200	70	550	413
10200	LT-710LB	1791	1005.4	97.1	91.4	54389	200	70	550	442

Rated power	Frame	Speed	Rated current	Efficiency	Power factor	Torque	Break down torque	Locked -rotor torque	Locked -rotor current	Rotor Inertia
P _N		n _N	I _N	100% load	100% load	T _N	T _{max} / T _N	T _s / I _N	I _s / I _N	J
kW		rpm	A	%	cos φ [%]	Nm	[%]	[%]	[%]	kgm
6.6kV, 60Hz										
6-Pole										
970	LT-450SB	1184	107.5	95.2	82.9	7824	210	90	600	40
1100	LT-450SB	1185	119.7	95.5	84.2	8865	200	70	550	44
1250	LT-450LB	1185	134.4	95.7	85.0	10074	200	80	550	50
1430	LT-450LB	1188	151.5	96.0	86.0	11495	200	80	550	54
1700	LT-500SB	1187	185.7	95.8	83.6	13677	200	80	620	86
1920	LT-500SB	1187	208.3	96.0	84.0	15447	200	80	580	91
2120	LT-500LB	1186	228.6	96.0	84.5	17071	200	70	580	100
2300	LT-500LB	1186	246.6	96.2	84.8	18520	200	70	550	106
2700	LT-560SB	1187	294.6	96.0	83.5	21723	200	70	600	143
3050	LT-560SB	1188	331.0	96.2	83.8	24518	190	65	550	150
3250	LT-560LB	1188	353.0	96.1	83.8	26126	190	65	580	168
3600	LT-560LB	1189	389.3	96.3	84.0	28915	190	65	550	179
4050	LT-630SB	1188	436.4	96.3	84.3	32557	200	80	650	291
4550	LT-630SB	1188	487.0	96.5	84.7	36576	200	75	630	308
4750	LT-630LB	1188	509.5	96.4	84.6	38184	200	95	650	321
5200	LT-630LB	1189	556.5	96.5	84.7	41766	210	95	650	345
5600	LT-710SB	1190	586.9	96.5	86.5	44941	200	90	620	463
6000	LT-710SB	1190	628.1	96.6	86.5	48151	200	80	600	489
6400	LT-710SB	1190	666.2	96.6	87.0	51361	190	80	550	510
7000	LT-710LB	1191	727.1	96.8	87.0	56129	200	90	620	550
7500	LT-710LB	1191	779.0	96.8	87.0	60139	200	100	650	569
8-Pole										
750	LT-450SB	890	87.2	95.0	79.2	8048	210	100	620	57
840	LT-450SB	891	96.9	95.3	79.6	9003	210	90	580	61
1030	LT-450LB	890	115.1	95.5	82.0	11052	200	100	600	69
1250	LT-500SB	890	139.6	95.5	82.0	13413	210	100	620	102
1400	LT-500SB	891	156.2	95.6	82.0	15006	210	100	600	114
1700	LT-500LB	891	189.0	95.7	82.2	18221	200	100	600	136
2000	LT-560SB	890	226.8	95.6	80.7	21461	210	100	620	167
2200	LT-560SB	892	248.0	95.8	81.0	23554	200	95	550	188
2400	LT-560LB	892	270.6	95.8	81.0	25695	200	90	580	206
2650	LT-560LB	892	299.2	95.9	80.8	28372	200	90	550	222
3000	LT-630SB	892	338.2	95.8	81.0	32119	200	90	620	319
3300	LT-630SB	893	371.2	96.0	81.0	35291	200	90	600	355
3500	LT-630LB	892	394.2	96.0	80.9	37472	200	90	620	371
3800	LT-630LB	893	428.5	96.0	80.8	40638	200	90	550	384
4400	LT-710SB	893	477.0	96.3	83.8	47055	200	90	580	536
4900	LT-710SB	893	526.8	96.3	84.5	52402	200	95	600	575
5400	LT-710LB	894	581.4	96.5	84.2	57685	200	90	600	608
6000	LT-710LB	894	645.2	96.5	84.3	64094	200	90	600	637

* Note - F/B, Ambient temperature 40°C
 - Above technical data are only design values and shall be guaranteed with tolerance of applicable standard. (IEC tolerance is applied).
 - Standard sound pressure level is 85dB(A) at no load.

LT Series / Dimension

Outline Dimension Drawing

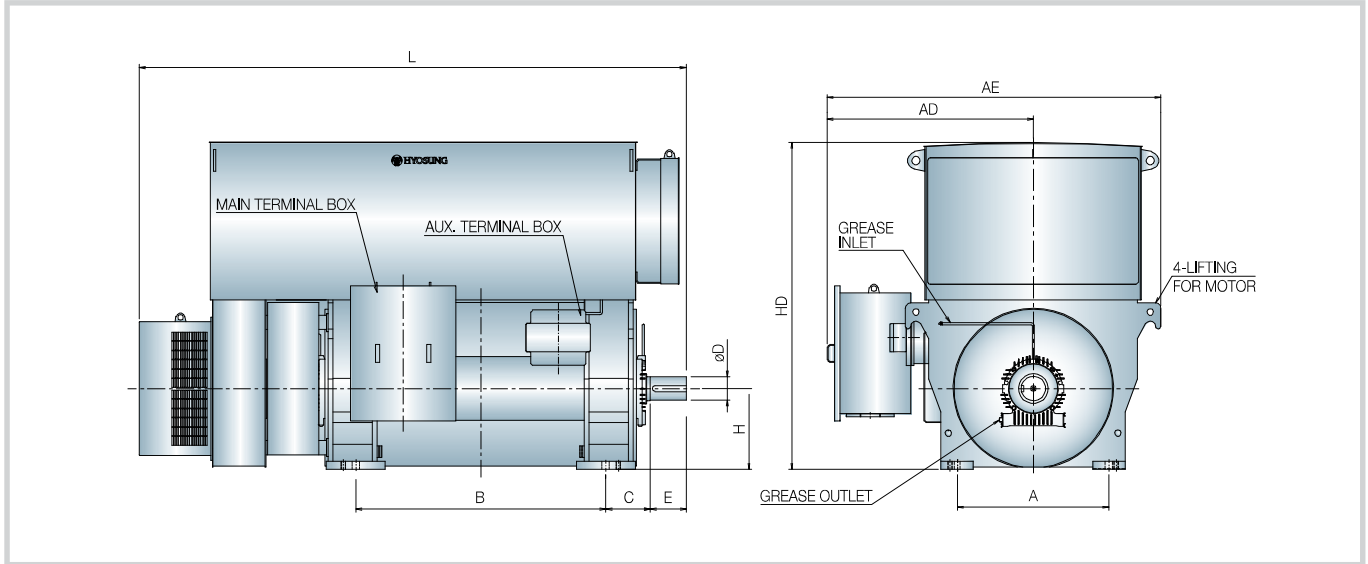

Motor type	Weight kg	Dimensions									
		A mm	AD mm	AE mm	B mm	C mm	D mm	E mm	H mm	HD mm	L mm
4P											
450S	4990	850	1152	1867	1180	250	120	165	450	1828	2813
450L	5800	850	1152	1867	1400	250	130	200	450	1828	3063
500S	6460	950	1218	2003	1320	280	140	200	500	1990	3046
500L	7510	950	1218	2003	1500	280	150	200	500	1990	3221
6P											
450S	4840	850	1152	1867	1180	250	130	200	450	1828	2455
450L	5620	850	1152	1867	1400	250	140	200	450	1828	2670
500S	6640	950	1218	2003	1320	280	150	200	500	1990	2579
500L	7720	950	1218	2003	1500	280	160	240	500	1990	2794
560S	8950	1060	1291	2186	1400	315	170	240	560	2275	2885.5
560L	10400	1060	1291	2186	1600	315	180	240	560	2275	3100.5
630S	13470	1320	1390	2375	1600	355	200	280	630	2610	3280
630L	15300	1320	1390	2375	1800	355	200	280	630	2610	3480
8P											
450S	4840	850	1152	1867	1180	250	130	200	450	1828	2455
450L	5620	850	1152	1867	1400	250	140	200	450	1828	2670
500S	6640	950	1218	2003	1320	280	150	200	500	1990	2579
500L	7720	950	1218	2003	1500	280	160	240	500	1990	2794
560S	8950	1060	1291	2186	1400	315	170	240	560	2275	2885.5
560L	10400	1060	1291	2186	1600	315	180	240	560	2275	3100.5
630S	13470	1320	1390	2375	1600	355	200	280	630	2610	3280
630L	15300	1320	1390	2375	1800	355	200	280	630	2610	3480

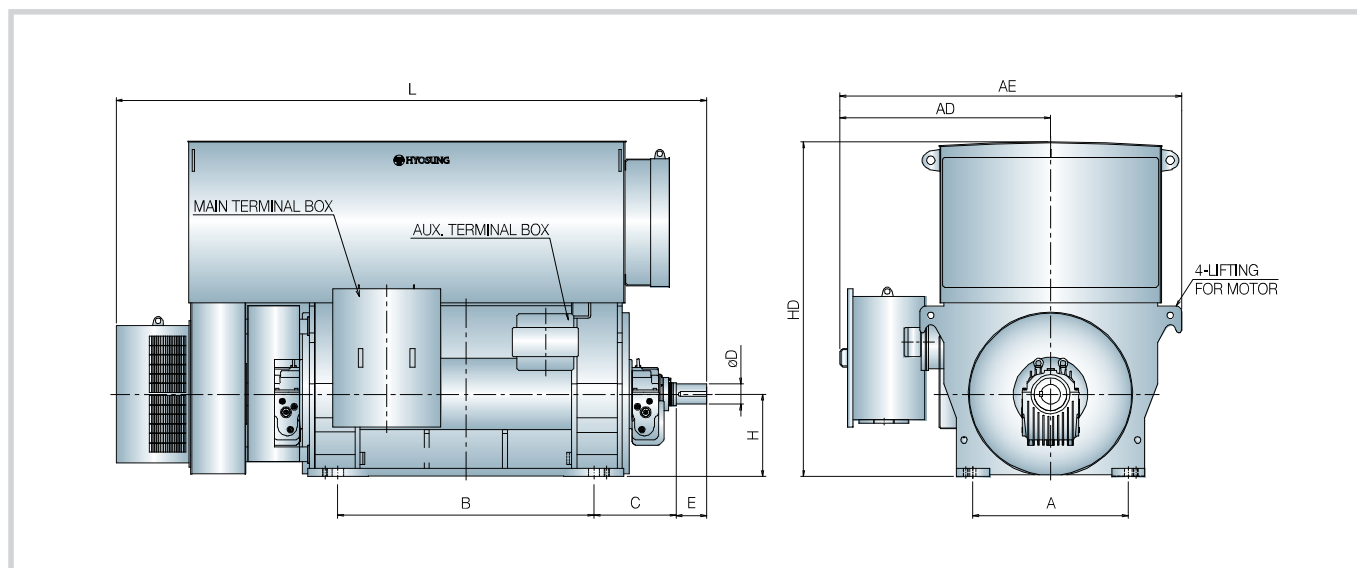

Motor type	Weight kg	Dimensions									
		A mm	AD mm	AE mm	B mm	C mm	D mm	E mm	H mm	HD mm	L mm
2P											
450S	4570	850	1152	1867	1180	450	100	165	450	1828	3013
450L	5250	850	1152	1867	1400	450	110	165	450	1828	3228
500S	5700	950	1218	2003	1320	475	110	165	500	1990	3046
500L	6750	950	1218	2003	1500	475	120	165	500	1990	3381
560S	8600	1060	1291	2186	1400	560	130	200	560	2275	3602
560L	11000	1060	1291	2186	1600	560	140	200	560	2275	3817
630S	11560	1320	1390	2375	1600	560	140	200	630	2610	3976
630L	15500	1320	1390	2375	1800	560	150	200	630	2610	4186
710L	23520	1500	1740	2860	2240	600	180	240	710	3075	5017
4P											
560S	9940	1060	1291	2186	1400	530	170	240	560	2275	3612
560L	10550	1060	1291	2186	1600	530	180	240	560	2275	3827
630S	13640	1320	1390	2375	1600	600	190	280	630	2610	4106
630L	15500	1320	1390	2375	1800	600	200	280	630	2610	4306
710S	24840	1500	1525	2645	2000	670	220	280	710	2880	4661
710L	27600	1500	1525	2645	2240	670	220	280	710	2880	4901
6P											
710L	27300	1500	1525	2645	2240	670	220	280	710	2880	4321
8P											
710L	27300	1500	1525	2645	2240	670	220	280	710	2880	4321

Optional Design & Test

Optional design

Optional or customised designs can be applied upon request.

- Change of ambient temperature
- Inverter duty
- Copper bar rotor for LF series (aluminum die-casting is basic design.)
- Direction of rotation (clockwise, counter-clockwise or bi-direction)
- DE bearing insulation (NDE bearing is insulated as basic design.)
- Change of bearing type (from anti-friction to sleeve, if applicable)
- Special terminal box (phase segregated type, elastimold type etc.)
- Change of location of the terminal box
- Special painting system
- Instrumentation & auxiliary terminal box
 - RTD's for bearings & windings, Transmitters
 - Vibration sensors, Current transformers
 - Surge arrestors & capacitors
 - Separate terminal boxes for space heater & RTD's
- Special packing
- Specified performance requirements such as current, torque etc.



Test description

Each motor is given tests which are deemed essential by Hyosung.

An unwitnessed routine test will be performed at no charge to all motors ordered.

1. Routine test

- Measurement of resistance of stator winding with DC, referred to 20°C (IEC 34, IEEE 112)
- No-load test (IEC 34) (measurement of no-load current and no-load losses at rated voltage and rated frequency)
- Insulation resistance test of stator/rotor winding (IEEE 43)
- Verification that phase sequence agrees with terminal markings
- Measurement and evaluation of vibrations (IEC 34)
- Mechanical balance
- High voltage test (IEC 34)

2. Complete test

- Routine test
- Determination of efficiency at full, 3/4, and 1/2 load (IEEE 112 F method)
- Determination of power factor at full, 3/4, and 1/2 loads (IEEE 112 F method)
- Temperature run by dual frequency method (IEC 61986, IEEE 112)
- Locked rotor current (Logarithmic proportion method)
- Determination of locked rotor and breakdown torques
- Sound pressure test

Optional test

- Sample coil test
- Bearing temperature rise test
- Others upon customer's request



Manufacturing Facilities

Manufacturing plant



- **Location** Changwon City, Korea
- **Land** 741,340 m²
- **Floor space** 343,252m²

Test description



VPI Tank



Winding Machine



Test Facility

Certificate



ISO 9001
Quality Management System



ISO 14001
Environment Management System



OHSAS 18001
Occupational Health & Safety
Assessment Series

Global Sales Network



*We are always
by your side.*



Asia

--- Bangkok Office

Tel. +66 2 653 2031
Room No. 1404, 14th Floor One Pacific
Place 142 Sukhumvit Road, Bangkok
10110, Thailand

--- Beijing Office

Tel. +86 10 6512 9692
Room No. 501 5/F., Scitech Tower #22 Jian
Guo Men Wai Street, Beijing, China

--- Jakarta Office

Tel. +62 21 526 6475
Citi Bank Tower 24/F., Plaza Bapindo Jl,
Jendral Sudirman Kav, 54-55 Jakarta
12920, Indonesia

--- Kuala Lumpur Office

Tel. +60 3 2031 2416
Suite 24-04, Level 24 Wisma Goldhill, No.
67, Jalan Raja Chulan, 50200 Kuala
Lumpur, Malaysia

--- Manila Office

Tel. +632 848 6204
12F Unit 1203, Ayala Tower 1, Ayala
Triangle, Ayala Avenue, Makti City,
Philippines

--- New Delhi Office

Tel. +91 11 4166 2255
D-4 Commercial Complex Paschimi Marg
2nd Floor, Vasant Vihar, New Delhi, India

--- Osaka Office

Tel. +81 6 6264 0778
Kokusai Bldg., 13F, 3-13, 2-Chome
Azuchi-Machi, Chuo-ku, Osaka, Japan

--- Seoul - Headquarters

Tel. +82 2 707 7000
450 Gongdeok-dong, Mapo-gu, Seoul,
Korea

--- Shanghai Office

Tel. +86 21 6209 0123
Room No. 1115, Shanghai International
Trading Center No. 2200 Yan An Xi Road,
Shanghai, China

--- Singapore - Hyosung Singapore Pte, Ltd.

Tel. +656 337 2079
250, North Bridge Road # 16-03, Raffles
City Tower, Singapore 179101

--- Taipei Office

Tel. +886 2 2758 4636
1714, 17F, International Trade Building No.
333 Sec1, Keelung Road, Taipei 110,
Taiwan R.O.C

--- Tokyo - Hyosung Japan

Tel. +81 3 3432 1005
Svax TT Bldg 6F, 11-15, 3-Chome,
Toranomon Minato-ku, Tokyo, Japan

Americas

--- Los Angeles Office – HICO America Inc. L.A Branch

Tel. +1 714 989 8900
910 Columbia Street, Brea, CA 92821,
USA

--- Pittsburgh – HICO America Inc.

Tel. +1 412 787 1170
One Penn Center West, Suite 212
Pittsburgh, PA 15276, USA

--- Mexico Office

Tel. +52 55 5250 2790
Paseo de Tamarindos 90, Torre 1, Piso 10,
Col. Bosques de las Lomas, C.P. 05120,
Mexico D.F., Mexico

--- Panama Office

Tel. +507 214 8968
International Business Center Piso 8, Ave.
Manuel Espinosa Bantista Bella Vista,
Apdo. 0819-06390, Panama City, Republic
of Panama

--- Sao Paulo – Hyosung Do Brazil

Tel. +55 11 3284 6436
Av. Eng. Luis Carlos Berrini, 1297 Conj 142,
Brooklin, Edificio Sudameris, Sao Paulo,
Brazil

Europe

--- Barcelona Office

Tel. +34 93 430 7735
Calle Valencia 243-245, 6-3 08007
Barcelona, Spain

--- Frankfurt Office

Tel. +49 6102 74120
Martin-Behaim Str. 12, 63263 Neu-
Isenburg, Germany

--- Istanbul Office

Tel. +90 212 284 1601
Harman Caddesi, Ali Kaya Sk. Polat Plaza
B Block, Kat 3, No. 76, Levent, Istanbul,
Turkey

--- Milan – Hyosung Europe S.r.l.

Tel. +39 02 9886 251
Via del Tecchione 34, 20098 San Giuliano
Milanese (MI), Italy

--- Moscow Office

Tel. +7 495 956 5172
Park Place E 323. 113/1, Lninsky Prospect
117198, Moscow, Russia

Middle East

--- Dubai Office

Tel. +971 4 221 8483
P.O. Box 15287, Office 804 Green Tower Al
Regga Street Deira, Dubai, UAE





2012. 04

www.tonson-motor.com.au
www.hyosungpni.com



HEAD OFFICE

Factory 19/5 Lyn Parade PRESTONS NSW 2170
TEL : 02 9607 4100 FAX : 02 9600 8882
sales@samt.com.au



HEAD OFFICE

450, Gongdeok-dong, Mapo-gu, Seoul, Korea
TEL : 82-2-707-6181 FAX : 82-2-707-6117