

Chain Idler

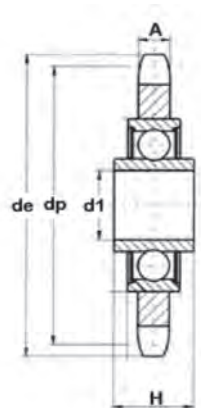

Idler Sprockets in conjunction with Tensioners provide an efficient solution to maintaining smooth running drives, inhibiting the effects of chain stretch and ensuring chains don't jump their drives.

These prefabricated Idler Sprockets employ a standard precision roller bearing.

Available in a range of sizes with pins to suit, this range of Idler Sprockets are designed for use in conjunction with the SE Series Tensioners.



Part No	Pitch	Teeth	de	dp	A	D1	Bolt	H
SE15/SE18-06B-15	3/8"	15	49.5	45.8	5.3	10	10X55	9
SE15/SE18-08B-15	1/2"	15	65.9	61.1	7.2	10	10X55	9
SE27-08B-15	1/2"	15	65.9	61.1	7.2	12	12X80	9
SE27-10B-15	5/8"	15	83.2	76.4	9.1	12	12X80	10
SE27-12B-15	3/4"	15	99.8	91.6	11.1	12	12X80	11.1
SE38-10B-15	5/8"	15	83.2	76.4	9.1	20	20X100	14
SE38-12B-15	3/4"	15	99.8	91.6	11.1	20	20X100	14
SE38-16B-13	1"	13	117.7	106.1	16.2	20	20X100	16
SE45-20B-13	1-1/4"	13	147.5	132.7	18.5	20	20X130	18

Combination Chain

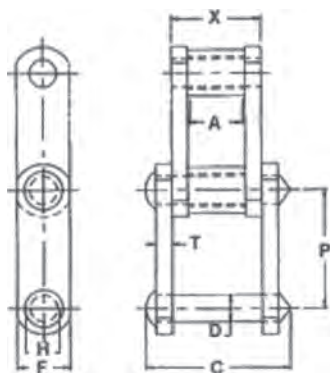

Chain	Pitch	A	C	D	E	F	H	T	X	App. Kg/ft
C55	41.43	17.45	52.37	9.53	49.99	19.05	18.24	4.75	31.75	0.91
C188	66.27	23.80	68.25	12.70	63.50	28.58	22.23	6.35	39.67	1.58
C102B	101.60	50.80	115.87	15.88	111.13	38.10	24.59	9.53	73.81	2.90