

SAMT
Specialised Air Motors and Transmission

GEAR COUPLING

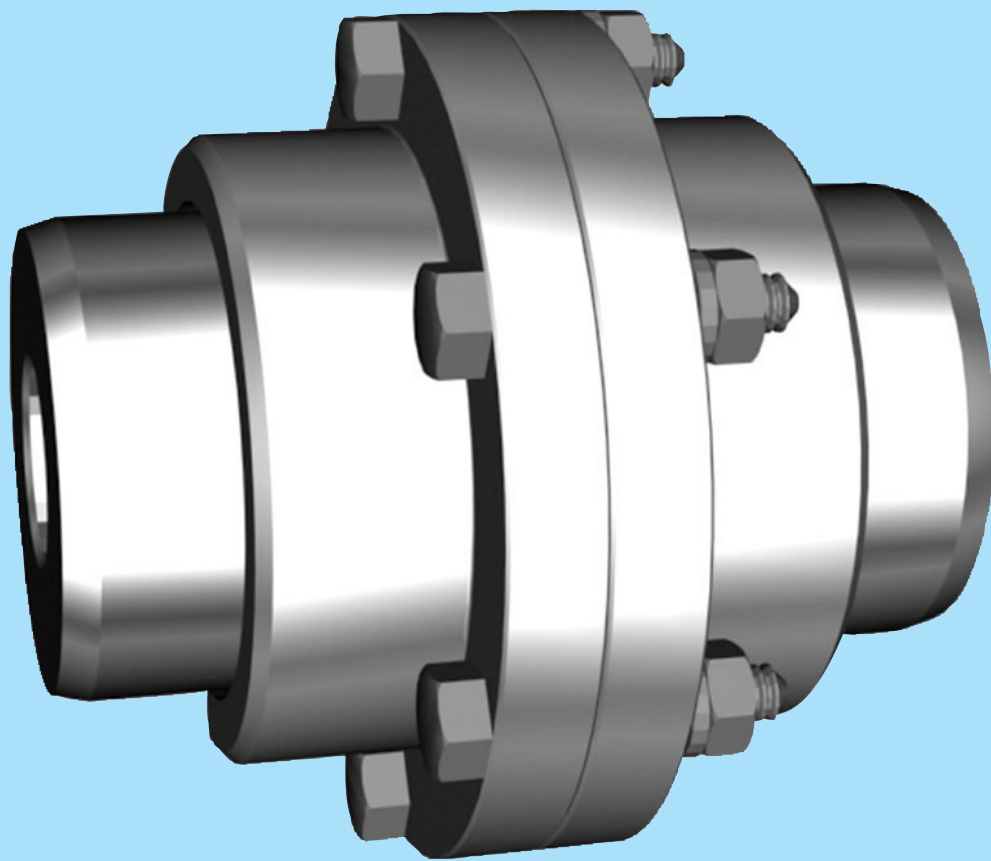

GEAR COUPLING

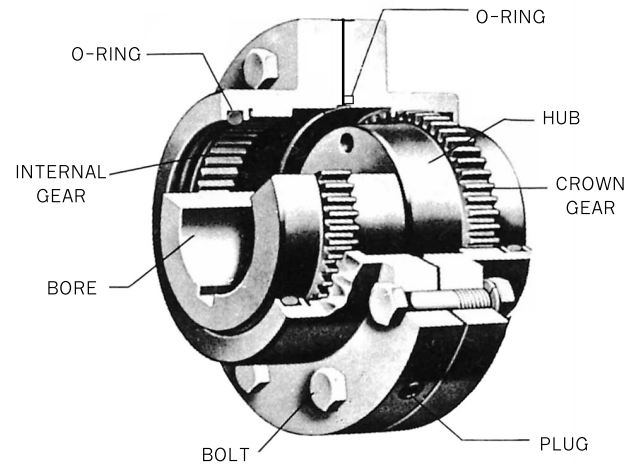
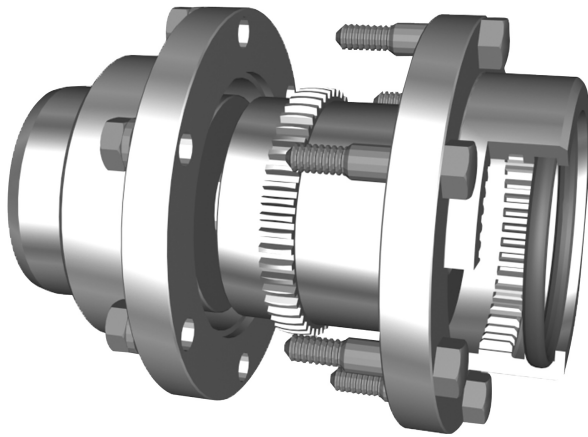

■ Structure

1. Gear coupling consists of the internal spur gears in its sleeves and the external spur gears with crowned teeth on its hubs, both of which are in mesh when assembled. At the tooth section of the hub, the tooth surface is crowned and the tooth top is rounded in the axial direction in order to prevent interference at the tooth section when they are operated in eccentric condition.
2. If it is properly mounted without any displacement the external tooth comes in contact with the mating internal tooth at the middle of the crowned portion (RO) and if it is mounted with offset and angular displacement, the former will come in contact with the latter at a point distant from the middle of the crowned portion.

Double Engagement

Double engagement provides for parallel misalignment, angular misalignment and end float with the ability to accommodate close coupled application requirements. Our Gear couplings are manufactured with the tooth of the outer gear in a crown shape so even when axial misalignment occurs it provides good operation.

Single Engagement

Single engagement accommodates angular misalignment only and does not allow for parallel misalignment. This design consists of a flexible and rigid half, most commonly used in floating shaft applications to solve remote drive and excessive misalignment problems.

Rigid Coupling

The GRC coupling consists of 2 rigid hubs and high tensile machine bolts. The simple construction means that the coupling is lubrication and maintenance free. Rigid couplings are ideal for applications where there is no misalignment.

Gear Spacer Coupling

This Double Engagement Spacer Coupling with Drop-out Spacers is suitable to take misalignment over increased distances between shaft ends. It is also able to compensate for Parallel and Angular misalignment. Our Gear couplings are manufactured with the tooth of the outer gear in a crown shape so even when axial misalignment occurs it provides good operation.

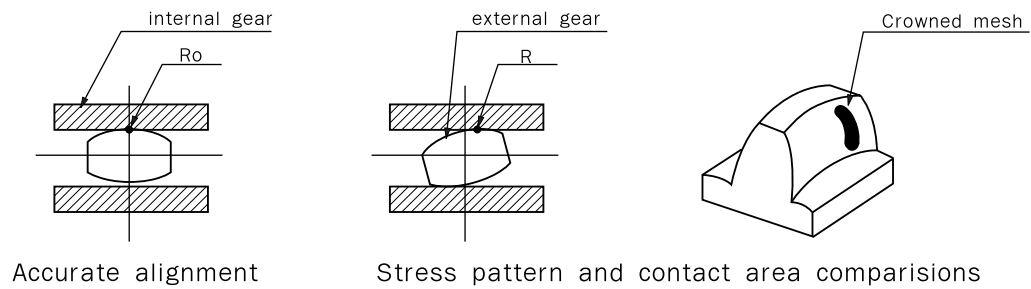

3. Misalignment

① Parallel Misalignment

The driving shaft and the driven shaft are parallel to each other but not on the same straight line.

② Angular Misalignment

The driving shaft and the driven shaft cross to each other but not on the same straight line.

③ Composite Misalignment

The driving shaft and the driven shaft do not cross to each other nor are they parallel to each other.

④ Axial Misalignment

The driving shaft and the driven shaft are on the same line but the distance between the two shafts varies (The permissible axial Misalignment is $\pm 25\%$ of C)

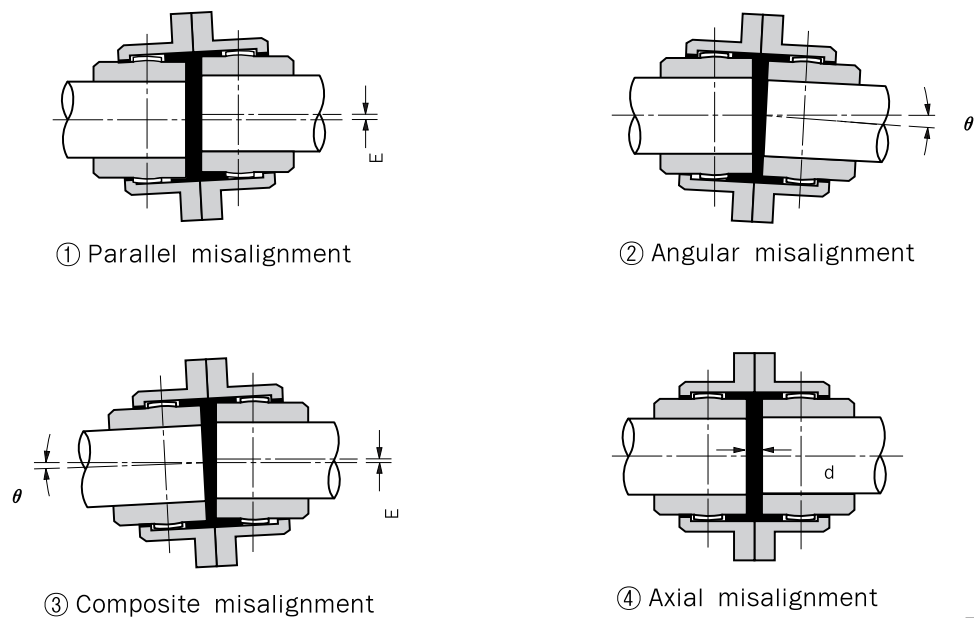

4. Allowable Amounts of Misalignments.

The following tables show the allowable amounts of displacement determined by a structural consideration. It is, therefore, practically recommended that the alignment should be made as accurately as possible according to the service conditions such as the place of application, type of machine, service rpm, etc.



Allowable amounts of misalignments of SSM, CCM-type

coupling Size	Parallel misalignment (mm)	Axial misalignment (mm)	Angular misalignment (°)	coupling Size	Parallel misalignment (mm)	Axial misalignment (mm)	Angular misalignment (°)	coupling Size	Parallel misalignment (mm)	Axial misalignment (mm)	Angular misalignment (°)
112	1	2	3°	250	2	4	3°	560	4	6.5	2°
140	1.25	2.5	3°	315	2.5	5	3°	710	5	8.5	2°
160	1.25	3	3°	355	3	5.5	3°	800	5.5	9.5	2°
180	1.5	3	3°	400	3	6.5	3°	900	6.5	10.5	2°
200	1.5	3	3°	450	3	5	2°	1000	7	12	2°
224	1.5	4	3°	500	3.5	6	2°	1120	8	13	2°

Allowable amounts of misalignments of GD, GDL-type

coupling Size	Parallel misalignment (mm)	Axial misalignment (mm)	Angular misalignment (°)	coupling Size	Parallel misalignment (mm)	Axial misalignment (mm)	Angular misalignment (°)	coupling Size	Parallel misalignment (mm)	Axial misalignment (mm)	Angular misalignment (°)
10	1	1.5	3°	40	3.4	3.5	3°	80	6.6	5	2°
15	1.3	1.5	3°	45	3.7	4	3°	90	7.5	5	2°
20	1.6	2	3°	50	4	4	3°	100	8.4	6	2°
25	2	3	3°	55	4.5	5	3°	110	12.3	6	2°
30	2.5	3	3°	60	5	5	3°	120	12.7	8	2°
35	3	3	3°	70	6	5	2°				

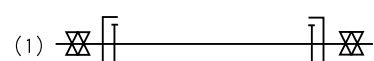
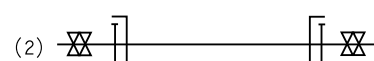
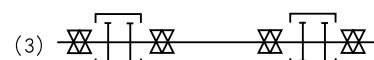
Application

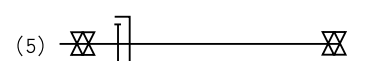
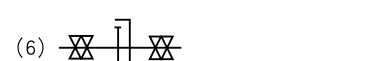
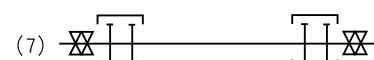
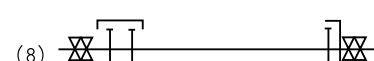
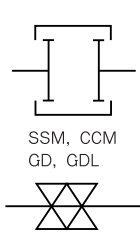
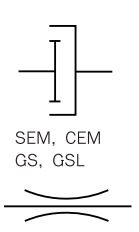
Recommendable	Not Recommendable	Symbol
   	   	 

- In case of SEM it will be used like (1) or (2). The case such as (5) must be basically avoided except for when shafts are in complete alignment.
- When SSM are coupled with an intermediate shaft, the shaft requires fixed supports as (3).
- When SSM is used together with SEM, an inclinable bearing supporting the intermediate shaft must be set up.
- If the intermediate shaft is in inclining state, it causes vibration.
- For use in high speed revolution, the allowable max. rpm of the coupling can be increased by adjusting the alignment and improving the balance of the coupling sleeves.

Fig. 6

■ Selection Method of Size

1. From the following formula, obtain torque required for selection,

$$T_a = 974 \times \frac{KW}{N} \times SF \quad \text{or} \quad T_a = 716 \times \frac{HP}{N} \times SF$$

T_a = Selected torque(kg.m)

KW = Transmitted load(kw)

HP = Transmitted load(HP)

N = Working revolution(rpm)

$S.F$ = Recommended Service Factor

2. First select the same or greater size by comparing with basic torque of each size and calculated torque and then examine the suitability of boring driver.

Recommended Service Factor (S.F)

table 4.

Driving machines			Load	Examples of driven machines
Electric motor or turbine	Hydraulic power	Reciprocation motion		
1	1.25	1.5	Smooth	Pumps, Blowers, Generators, and Exciters.
1.5	1.8	2	Light shock	Compressors, Mixers, Grinders, Machine Tools, Wood Working Machines, and Textile Machines.
2	2.3	2.5	Medium shock	Ball and Roll Mills, Reciprocating Compressors, Elevators, Paper Machines, Punch Presses.
2.5	2.8	3	Heavy shock	Steel & Iron Manufacturing Machines, Mining Machines, Roll Mills, and Rubber Mixers.
3	3.5	4	Extremely heavy shock	Ore Crushers, Vibration Conveyors, and Cutters.

* The above service factors are applied to the general conditions, the service factor should be considered according to the actual conditions.

■ Designation

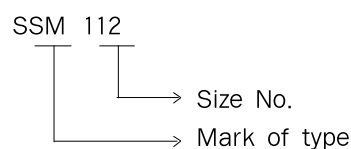

SSM, GD : Gear double engagement type
 CCM, GDL: Gear double engagement large type
 SEM, GS : Gear Single engagement type
 CEM, GSL: Gear Single engagement large type

■ Dimensions

SSM

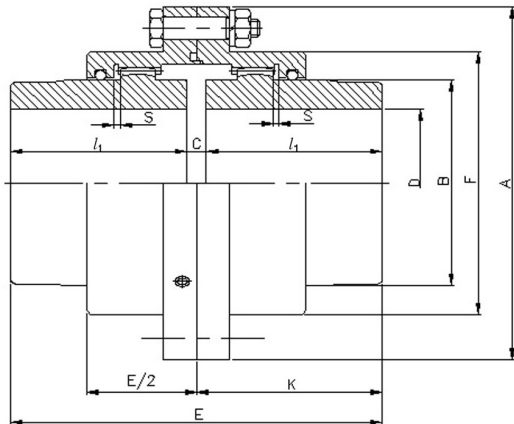

CCM

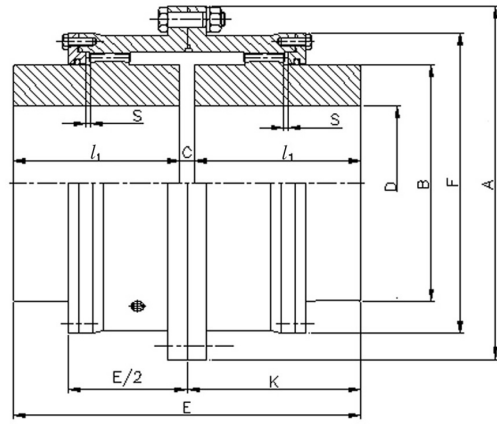

SIZE	Torque Rating (kgf • m)	Max Speed (rpm)	Dimensions(mm)									GREASE Q'TY (l)	Weight (kg)	GD ² (kgf • m ²)
			Bore D		E	l ₁	C	B	F	K	S			
OUTSIDE Dia A			Min	Max										
SSM 112	80.3	4000	17	40	108	50	8	58	79	40	2	0.055	4.3	0.0198
SSM 125	142	4000	22	50	134	63	8	70	92	43	2.5	0.072	6.6	0.0353
SSM 140	205	4000	22	56	150	71	8	80	107	47	2.5	0.11	9.3	0.0612
SSM 160	314	4000	22	65	170	80	10	95	120	52	3	0.14	14	0.113
SSM 180	482	4000	32	75	190	90	10	105	134	56	3	0.18	19	0.191
SSM 200	689	3810	32	85	210	100	10	120	149	61	3	0.24	26	0.315
SSM 224	1000	3410	42	100	236	112	12	145	174	65	4	0.36	39	0.599
SSM 250	1470	3050	42	115	262	125	12	165	200	74	4	0.53	55	1.08
SSM 280	2340	2720	42	135	294	140	14	190	224	82	4.5	0.69	80	2.06
SSM 315	3680	2420	100	160	356	170	16	225	260	98	5.5	1.1	129	4.24
SSM 355	5550	2150	125	180	396	190	16	250	288	108	5.5	1.3	177	7.13
SSM 400	7790	1900	140	200	418	200	18	285	329	114	6.5	2.0	242	12.5
CCM 450	11000	1690	140	205	418	200	18	290	372	151	5	2.6	298	16.6
CCM 500	16600	1520	170	250	494	236	22	335	424	168	6	3.8	446	36.9
CCM 560	25500	1360	190	280	552	265	22	385	472	187	6.5	4.6	642	67.6
CCM 630	42000	1210	224	325	658	315	28	455	544	213	8	6.7	1010	137
CCM 710	61200	1070	250	360	738	355	28	510	622	242	8.5	9.4	1440	250
CCM 800	87500	950	280	405	832	400	32	570	690	267	9.5	13	2030	441
CCM 900	125000	840	315	475	932	450	32	670	792	295	10.5	17	3030	860
CCM 1000	171000	760	355	510	1040	500	40	720	858	322	12	23	4120	1380
CCM 1120	240000	682	400	600	1160	560	40	840	990	360	13	31	5920	2650
CCM 1250	331000	610	500	710	1460	710	40	960	1126	399	14	45	9410	5290

■ Dimensions

SEM

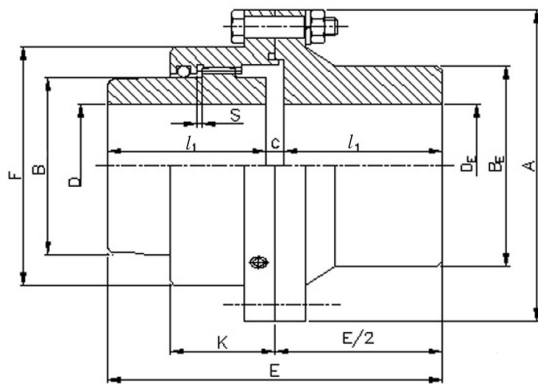

CEM

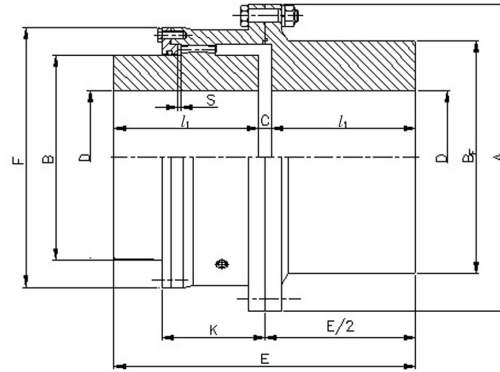

SIZE	Torque Rating (kgf · m)	Max Speed (rpm)	Dimensions(mm)												GREASE Q'TY (l)	Weight (kg)	GD ² (kgf · m ²)
			Bore D		Bore D _E		E	l ₁	C	B	F	K	B _E	S			
			Min	Max	Min	Max											
SEM 112	80.3	4000	17	40	17	50	108	50	8	58	79	40	70	2	0.042	4.6	0.0197
SEM 125	142	4000	22	50	22	56	134	63	8	70	92	43	80	2.5	0.056	6.7	0.0348
SEM 140	205	4000	22	56	22	63	150	71	8	80	107	47	90	2.5	0.085	9.3	0.0591
SEM 160	314	4000	22	65	22	75	170	80	10	95	120	52	105	3	0.11	14	0.111
SEM 180	482	4000	32	75	32	80	190	90	10	105	134	56	115	3	0.14	19	0.183
SEM 200	689	3810	32	85	32	95	210	100	10	120	149	61	135	3	0.18	26	0.317
SEM 224	1000	3410	42	100	42	105	236	112	12	145	174	65	150	4	0.29	38	0.579
SEM 250	1470	3050	42	115	42	125	262	125	12	165	200	74	180	4	0.41	56	1.08
SEM 280	2340	2720	42	135	42	150	294	140	14	190	224	82	210	4.5	0.56	83	2.14
SEM 315	3680	2420	100	160	100	180	356	170	16	225	260	98	250	5.5	0.90	135	4.55
SEM 355	5550	2150	125	180	125	200	396	190	16	250	288	108	275	5.5	1.1	184	7.50
SEM 400	7790	1900	140	200	140	236	418	200	18	285	329	114	325	6.5	1.6	261	14.1
CEM 450	11000	1690	140	205	140	225	418	200	18	290	372	151	320	5	2.1	304	18.2
CEM 500	16600	1520	170	250	170	270	494	236	22	335	424	168	380	6	3.1	453	37.0
CEM 560	25500	1360	190	280	190	305	552	265	22	385	472	187	430	6.5	3.8	664	70.0
CEM 630	42000	1210	224	325	224	355	658	315	28	455	544	213	500	8	5.8	1020	139
CEM 710	61200	1070	250	360	250	400	738	355	28	510	622	242	565	8.5	7.8	1460	252
CEM 800	87500	950	280	405	280	450	832	400	32	570	690	267	635	9.5	11	2090	451
CEM 900	125000	840	315	475	315	510	932	450	32	670	792	295	715	10.5	14	3020	743
CEM 1000	171000	760	355	510	355	570	1040	500	40	720	858	322	800	12	20	4130	1440
CEM 1120	240000	682	400	600	400	640	1160	560	40	840	990	360	900	13	26	5970	2810
CEM 1250	331000	610	500	710	500	800	1460	710	40	960	1126	399	1060	14	37	9820	5630

■ Dimensions

GD

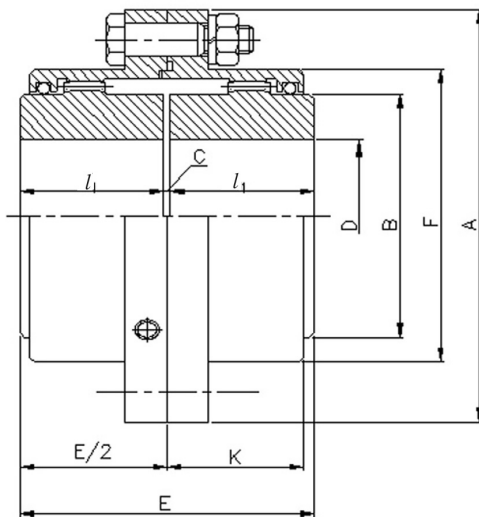

GDL

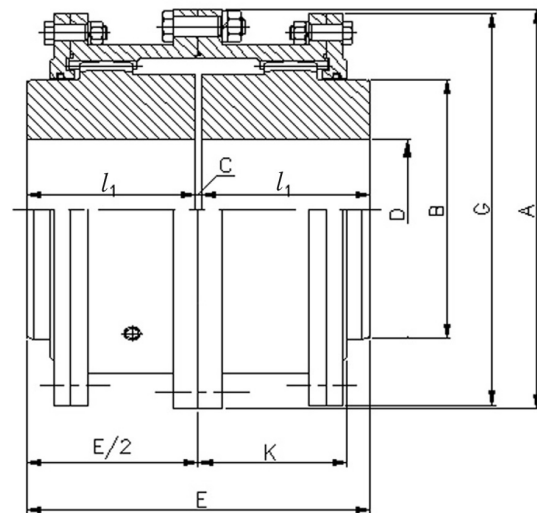

Size	HP Per 100 rpm	Max. Speed (rpm)	Basic Torque (kgf · cm)	Bore D(mm)		Dimensions(mm)								Weight (kg)	Grease wt(kg)
				Max	Min	A	E	l ₁	B	F	K	G	C		
10GD	12	8,000	8,594	48	13	116	89	43	69	84	39		3	4.5	0.04
15GD	27	6,500	19,337	60	19	152	101	49	86	105	48		3	9.1	0.07
20GD	50	5,600	35,810	73	25	178	127	62	105	126	59		3	15.9	0.11
25GD	90	5,000	64,458	92	32	213	159	77	131	155	72		5	29.5	0.23
30GD	150	4,400	107,430	105	38	240	187	91	152	180	84		5	43.1	0.36
35GD	230	3,900	164,726	124	51	279	218	106	178	211	98		6	68.0	0.54
40GD	350	3,600	250,670	146	64	318	248	121	210	245	111		6	97.5	0.91
45GD	480	3,200	343,776	165	76	346	278	135	235	274	123		8	136.1	1.04
50GD	650	2,900	465,530	178	89	389	314	153	254	306	141		8	190.5	1.77
55GD	850	2,650	608,770	197	102	425	344	168	279	334	158		8	249.5	2.22
60GD	1,100	2,450	787,820	222	114	457	384	188	305	366	169		8	306.2	3.18
70GDL	1,600	2,150	1,145,920	254	89	527	451.5	221	343		196	517	9.5	485.4	4.35
80GDL	2,100	1,750	1,504,020	279	102	591	507.5	249	356		243	572	9.5	703.1	9.53
90GDL	2,850	1,550	2,041,170	305	114	660	565	276	394		265	641	13	984.3	12.25
100GDL	4,000	1,450	2,864,800	343	127	711	623	305	445		294	699	13	1302.0	14.97
110GDL	5,500	1,330	3,939,400	387	140	775	679	333	495		322	749	13	1678.3	17.69
120GDL	7,000	1,200	5,013,400	425	152	838	719	353	546		341	826	13	2113.8	20.87

■ Dimensions

GS

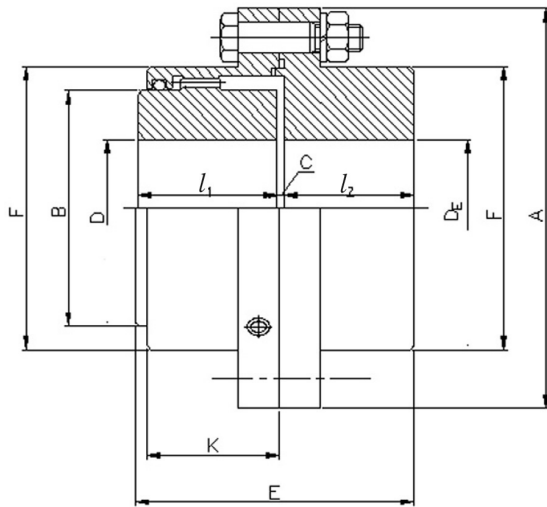

GSL

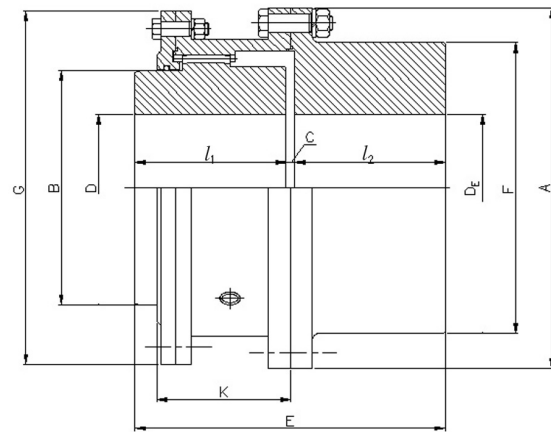

Size	HP Per 100 rpm	Max. Speed (rpm)	Basic Torque (kgf · cm)	Bore D(mm)			Dimensions(mm)									Weight (kg)	Grease wt(kg)
				Max		Min	A	E	l ₁	B	F	K	l ₂	G	C		
				D _E	D												
10GS	12	8,000	8,594	60	48	13	116	87	43	69	84	39	40		4	4.5	0.02
15GS	27	6,500	19,337	75	60	19	152	99	49	86	105	48	46		4	9.1	0.04
20GS	50	5,600	35,810	92	73	25	178	124	62	105	126	59	58		4	15.9	0.07
25GS	90	5,000	64,458	111	92	32	213	156	77	131	155	72	74		5	27.2	0.12
30GS	150	4,400	107,430	130	105	38	240	184	91	152	180	84	88		5	43.1	0.18
35GS	230	3,900	164,726	149	124	51	279	213.5	106	178	211	98	102		5.5	61.2	0.27
40GS	350	3,600	250,670	171	146	64	318	243	121	210	245	111	115		7	99.8	0.47
45GS	480	3,200	343,776	194	165	76	346	274	135	235	274	123	131		8	136.1	0.57
50GS	650	2,900	465,530	222	178	89	389	309	153	254	306	141	147		9	195.0	0.91
55GS	850	2,650	608,770	248	197	102	425	350	168	279	334	158	173		9	263.1	1.13
60GS	1,100	2,450	787,820	267	222	114	457	384	188	305	366	169	186		10	324.3	1.70
70GSL	1,600	2,150	1,145,920	305	254	89	527	454	221	343	425	196	220	517	13	508.0	2.27
80GSL	2,100	1,750	1,504,020	343	279	102	591	511	249	356	451	243	249	572	13	698.5	4.99
90GSL	2,850	1,550	2,041,170	381	305	114	660	566	276	394	508	265	276	641	14	984.5	6.35
100GSL	4,000	1,450	2,864,800	406	343	127	711	626	305	445	530	294	305	699	16	1251.9	7.71
110GSL	5,500	1,330	3,939,400	445	387	140	775	682	333	495	584	322	333	749	16	1637.5	9.07
120GSL	7,000	1,200	5,013,400	495	425	152	838	722	353	546	648	341	353	826	16	2077.5	10.89

■ Dimensions

Brake Drum Type

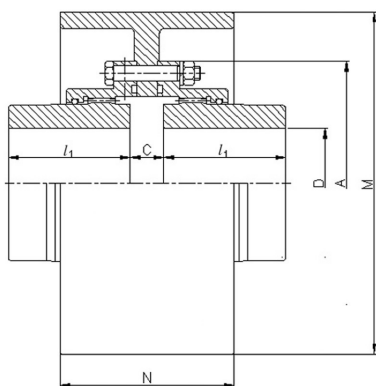

SSMB
GDBW

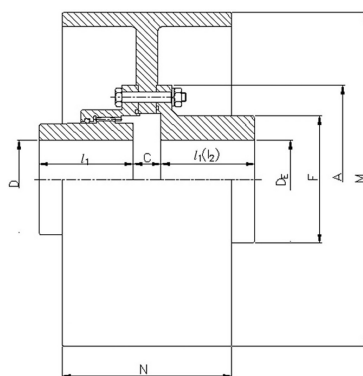

SEMB
GSBW

Brake Disc Type

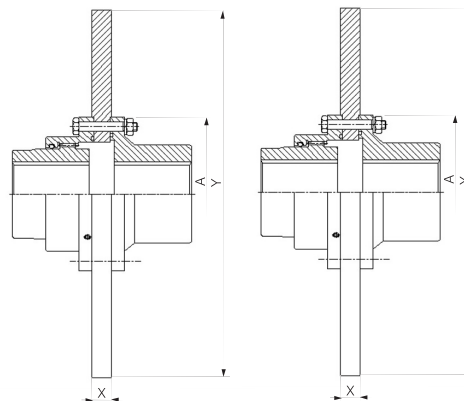

SSMB					DRUM SIZE		GDBW, GSBW						
Size	l_1	C	D	DE	M	N	DE	D	C	l_1	l_2	A	Size
			max/min	max/min			max/min	max/min					
140	63	24	56/22	63/22	200	100	75/19	60/19	16	49	46	152	15G
160	80	26	65/22	75/22			95/25	73/25	16	62	58	178	20G
180	90	29	75/32	80/32	250	125	113/32	92/32	19	77	74	213	25G
200	100	29	85/32	95/32									
224	112	31	100/42	105/42	315	160	130/38	105/38	19	91	88	240	30G
250	125	31	115/42	125/42									
280	140	31	135/42	150/42	355	180	149/51	124/51	25	106	102	279	35G
315	160	41	160/100	180/100	400	200	171/64	146/64	25	121	115	318	40G
355	180	43	180/125	200/125	450	224	194/76	165/76	27	135	131	346	45G
400	200	49	200/140	236/140	500	250	222/89	178/89	33	153	147	389	50G

* 'M' and 'N' are variable according to the space of machine.

Mill Motor Type

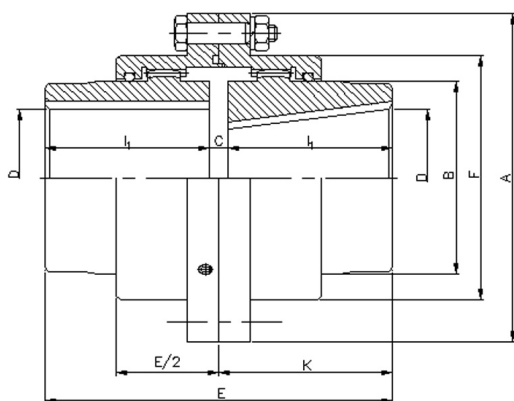

SMM

Size	DIMENSIONS						GD ² (kgf·m ²)
OUTSIDE Dia A	E	l_1	l_2	C	K ₁	K ₂	
SMM 125(a)	157	50	75	32	43	66	0.038
SMM 125(b)	172	50	90	32	43	66	0.039
SMM 140	185	63	90	32	47	72	0.066
SMM 160	220	80	100	40	52	82	0.123
SMM 180	246	90	115	41	56	87	0.208
SMM 200	260	100	115	45	61	93	0.336
SMM 224	289	112	125	52	65	102	0.637
SMM 250	305	125	125	55	74	105	1.09
SMM 280(a)	339	140	140	59	82	115	2.09
SMM 280(b)	339	140	150	49	82	115	2.13
SMM 315(a)	386	160	170	56	98	128	4.27
SMM 315(b)	421	160	185	76	98	143	4.42
SMM 355	491	180	235	76	108	155	7.79

■ Special Applications

Space Type Gear Coupling

SAM
GDS

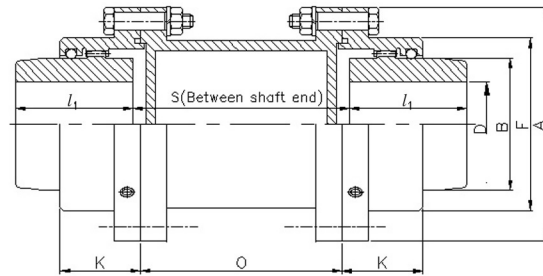

SSM112 ~ 400
GD10 ~ 60

CAM

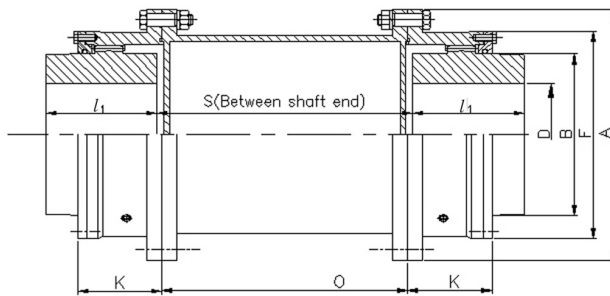

CCM450 ~ 1250

* "S" is the distance between shaft ends. Please give us the further information on "S" when you order.

With Flex Hub on Floating Shaft

SHM
GFO

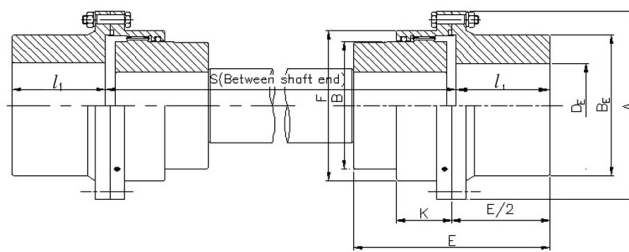

With Flange on Floating Shaft

SFM
GFR

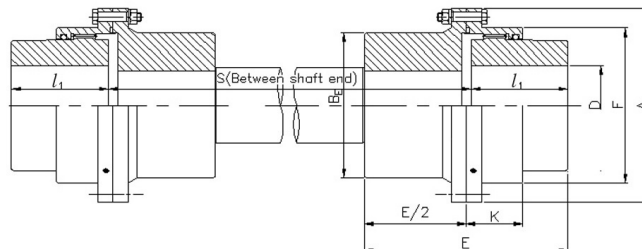

* "S" is the distance between shaft ends. Please give us the further information on "S" when you order.

NOTE) The detail dimensions on the above figures are the same as our original standard size(SSM, SEM, GD, GS)on the page 10 through page 13.

■ Special Applications

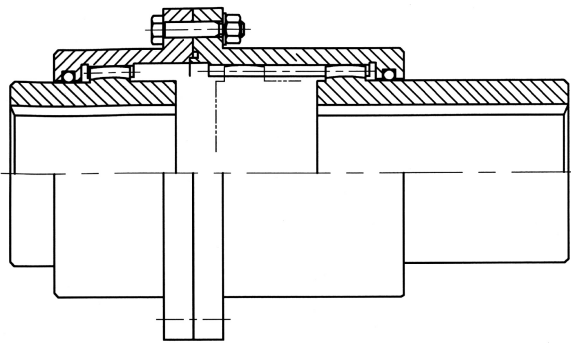

SLIDE TYPE

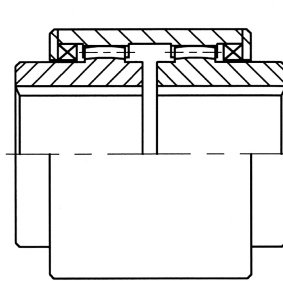

SLEEVE TYPE

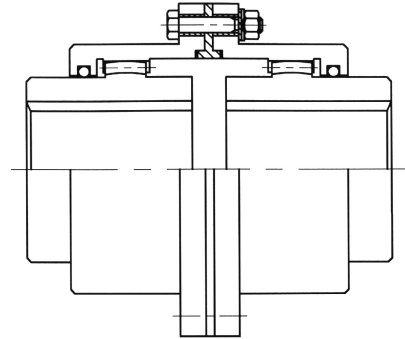

INSULATION TYPE

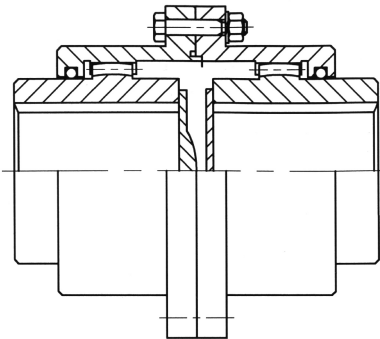

LIMITED-END PLAY TYPE

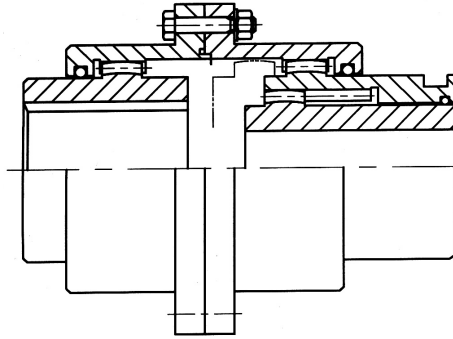

DETACHABLE CLUTCH TYPE

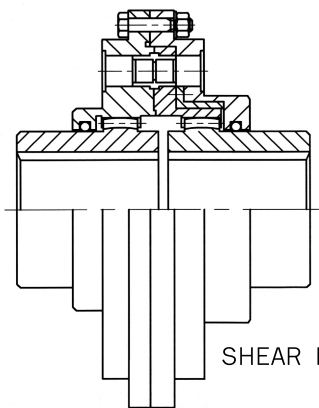
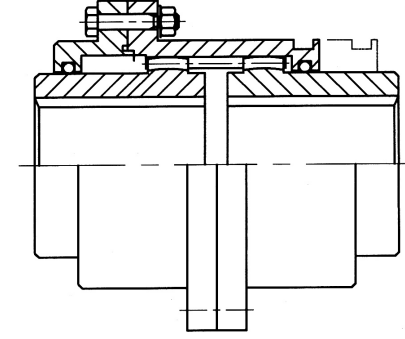

SHEAR PIN TYPE

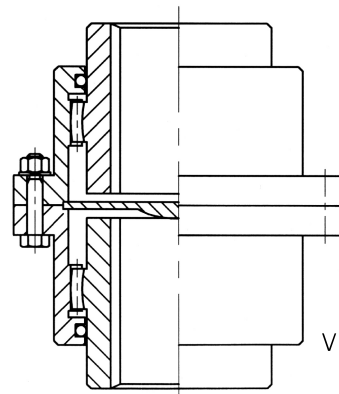

VERTICAL TYPE

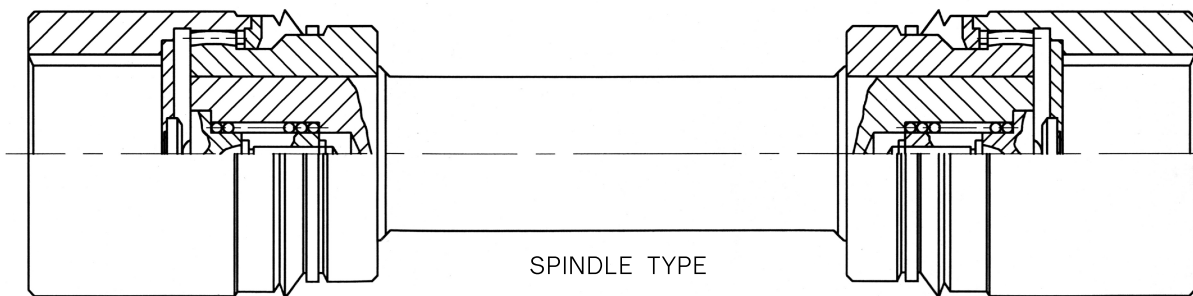

SPINDLE TYPE