



Factory 19 / 5 Lyn Parade

Prestons NSW 2170

Ph: 02 9607 4100

Fax: 02 9607 4200

Website: www.tonson-motor.com.au

Email: sales@samt.com.au



Variable Speed Drives



Specialised Air Motors & Transmission (SAMT) - incorporating TONSON - was founded in 1966 and provides efficient solutions and equipment to all major industries including mining, chemical, food, paper, plastic, power transmission, manufacturing and pharmaceutical.

Our commitment to you is best service, quick lead times and very competitive prices.

Innovation & Quality

Specialised Air Motors & Transmission is committed to providing clever solutions for all hazardous environments and continues to develop smart ways to meet requirements from all different industries; our products meet CE standards ISO9002, ISO9001 and patents are registered globally including USA, Taiwan and China.

Unlike other conventional methods our products mainly use air instead of electricity as the source of power. This eliminates the chance of electricity shock and fire, which are the most crucial factors for industries involved in chemical, flammable or volatile contents.

Specialised Air Motors & Transmission products include air/electric motors, air/electric mixers and air fans which are engineered to meet the highest standards featuring 100% explosion-proof, low air consumption, light weight, high torque, reversible step less speed control, easy maintenance and various mounting methods. And can be used in very harsh conditions such as humidity, high temperature and flammable environments.

Products & Services

SAMT's other popular products include Pressure Tanks up to 200L (with and without integrated mixer), spray guns, pneumatic double diaphragm pumps, vertical pumps, magic drum carriers, non-spark drum openers, propellers, plus many more exciting and innovative products.

We also have the technical capability and expertise to provide complete power transmission solutions to meet your specific requirements, including full engineering assistance with design, selection and site installation. We also specialise in the supply of all types of Industrial gearboxes including Helical, Worm, Bevel-Helical, Bevel, screw jacks and planetary. All are interchangeable with other internationally recognised brands.

SAMT can also customise any product to suit your specific requirements and will investigate the possibilities of developing new products to satisfy your special specifications.





CONTENTS

SS800 E Series Super Mini Inverter.....	04 - 06
<i>Compact design, easy operation</i>	
SS900 S Series-Mini Inverter.....	07 - 09
<i>Delta appearance, high performance</i>	
SZ900 E Series Vector Control Compact Inverter.....	10 - 13
<i>with open loop for general purpose</i>	
SS2100 S Series Intellegent Inverter.....	14 - 17
<i>IP65, waterproof</i>	



SS800 E Series-Mini Inverter

Compact Size Design, Small Appearance, Easy to Operate.

Product Specification

Items		SS800 E
Power Supply	Rated voltage, Frequency	One-phase/Three-phase AC 220V 50/60Hz;
	Voltage Range	220V: 170V~240V; 380V:330V~440V
Output	Voltage Range	220V: 0~220V; 380V:0~380V
	Frequency Range	0.10~400.00Hz
Control method		V/F control, Space vector control.
Indication		Operating status/Alarm definition/interactive guidance: eg, frequency setting, the output frequency/current, DC bus voltage, the temperature and so on.
Control Specifications	Output Frequency Range	0.10Hz~400.00Hz
	Frequency Setting Resolution	Digital input : 0.1 Hz, analog input: 0.1% of maximum output frequency
	Output Frequency Accuracy	0.1Hz
Control Specifications	V/F Control	Setting V/F curve to satisfy various load requirements.
	Torque Control	Auto increase: auto raise torque by loading condition; Manual increase:enable to set 0.0~20.0% of raising torque.
	Multifunctional Input Terminal	Four multi-function input terminals, realizing functions including fifteen section speed control, program running, four-section acceleration/ deceleration speed switch, UP/DOWN function and emergency stop and other functions
	Multifunctional Output Terminal	1 multi-function output terminals for displaying of running, zerospeed, counter, external abnormality, program operation and other information and warnings.
	Acceleration/ deceleration Time Setting	0~999.9s acceleration/deceleration time can be set individually.
Other Functions	PID Control	Built-in PID control
	RS485	Standard RS485 communication function (MODBUS)
	Frequency Setting	Analog input:0 to 10V, 4 to 20mA can be selected; Digital input: Input using the setting dial of the operation panel or RS485or UP/DOWN. Note: AVI terminals can be used to select an analog voltage input (0-10V) and analog current input (4-20mA) through the switch J2.

Items		SS800 E
Other Functions	Multi-speed	Four multifunction input terminals, 15 section speed can be set
	Automatic voltage regulation	Automatic voltage regulation function can be selected
	Counter	Built-in 2 group of counters
Protection/ Warning Function	Overload	150%, 60second (Constant torque)
	Over Voltage	Over voltage protection can be set.
	Under Voltage	Under voltage protection can be set.
	Other Protections	Output shortcircuit, over current, and parameter lock and so on.
Environment	Ambient Temperature	-10°C to 40°C (non-freezing)
	Ambient Humidity	Max. 95% (non-condensing)
	Altitude	Lower than 1000m
	Vibration	Max. 0.5G
Structure	Cooling Mode	Forced air cooling
	Protective Structure	IP 20
Installation	Mode	Wall-mounted or standard 35MM rail mounting

Specification

Unit: mm

Model	Power Output (KW)	Capacity (KVA)	Current Output (A)	Input current (A)	Motor Equipped (KW)
-------	-------------------	----------------	--------------------	-------------------	---------------------

1PH AC220V ±15% 50/60Hz

SS800-0.4	0.4	1.0	2.5	3.75	0.4
SS800-0.75	0.75	2.0	5.0	7.50	0.75
SS800-1.5	1.5	2.8	7.0	10.50	1.5
SS800-2.2	2.2	4.2	11.0	16.5	2.2

3PH AC380V ±15% 50/60Hz

SS800-0.75	0.75	2.2	2.7	4.05	0.75
SS800-1.5	1.5	3.2	4.0	6.0	1.5
SS800-2.2	2.2	4.0	5.0	7.5	2.2

Dimension

Unit: mm

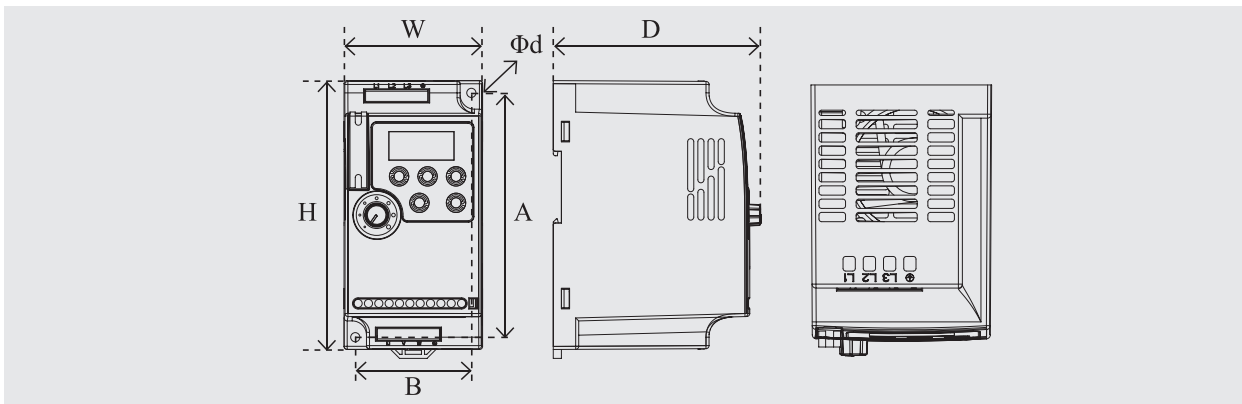

Model	W	H	D	A	B	Φd
SS800-0.4	68	132	102	120	57	Φ4.5
SS800-0.75						
SS800-1.5						
SS800-2.2	72	142	112.2	130	61	Φ4.5
SS800-1.5						
SS800-2.2						

Note: Support for standard 35 mm rail mounting

SS800E Typical Wiring Diagram

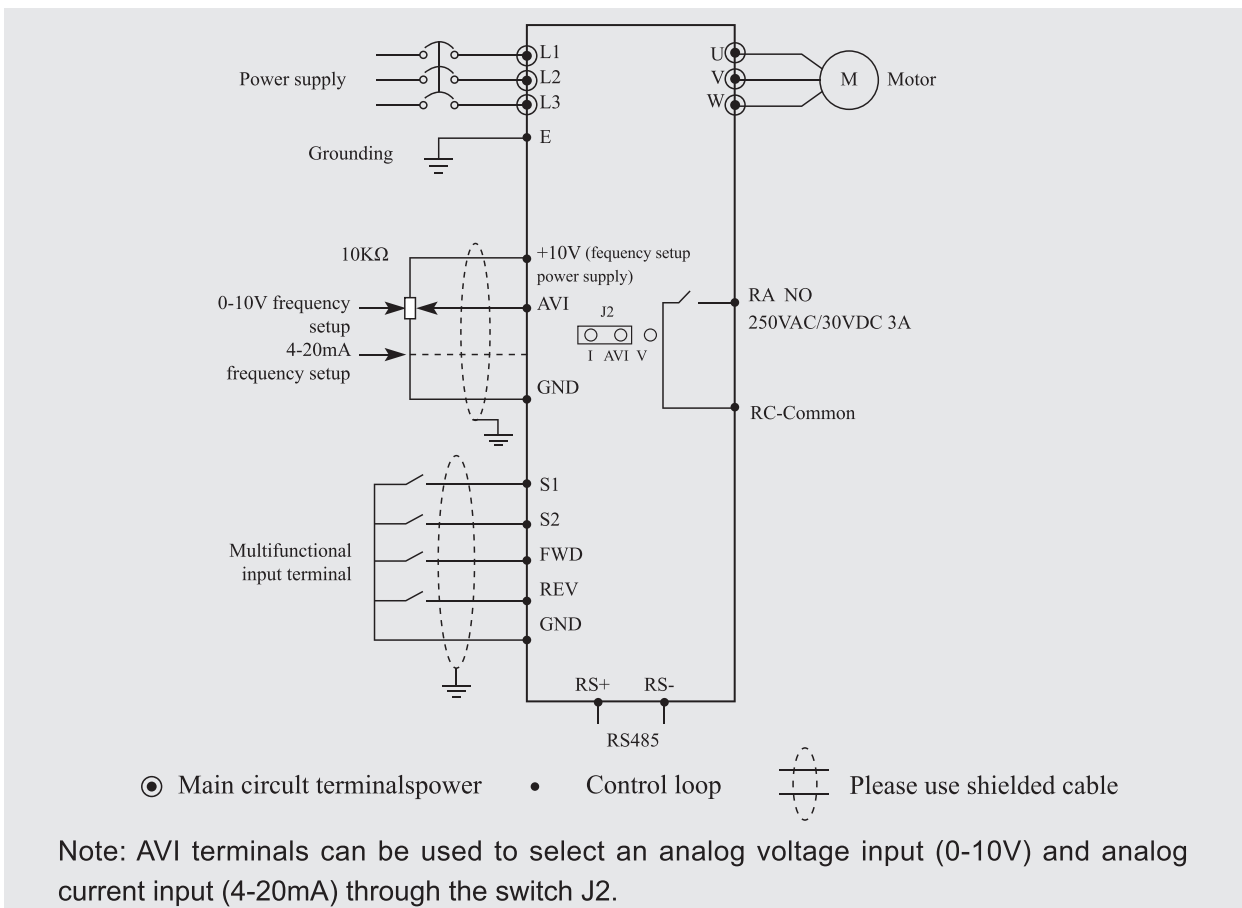

SS900 S Series-Mini Inverter

Compact size design, small Appearance, easy to operate



Product Specification

Items		SS900 S
Power Supply	Rated voltage, Frequency	One-phase/Three-phase AC 220V 50/60Hz; Three-phase AC 380V 50/60Hz
	Voltage Range	220V: 170V~240V; 380V: 330V~440V
Output	Voltage Range	220V: 0~220V; 380V: 0~380V
	Frequency Range	0.10~400.00Hz
Control method		V/F control, Space vector control.
Indication		Operating status/Alarm definition/interactive guidance: eg, frequency setting, the output frequency/current, DC bus voltage, the temperature and so on.
Control Specifications	Output Frequency Range	0.10Hz~400.00Hz
	Frequency Setting Resolution	Digital input : 0.01 Hz, analog input: 0.1% of maximum output frequency
	Output Frequency Accuracy	0.01Hz
	V/F Control	Setting V/F curve to satisfy various load requirements.
	Torque Control	Auto increase: auto raise torque by loading condition; Manual increase:enable to set 0.0~20.0% of raising torque.
	Multifunctional Input Terminal	Six multi-function input terminals, realizing functions including fifteen section speed control, program running, four-section acceleration/deceleration speed switch, UP/DOWN function and emergency stop and other functions
	Multifunctional Output Terminal	2 multi-function output terminals for displaying of running, zerospeed, counter, external abnormality, program operation and other information and warnings.
	Acceleration/ deceleration Time Setting	0~999.9s acceleration/deceleration time can be set individually.
Other Functions	PID Control	Built-in PID control
	RS485	Standard RS485 communication function (MODBUS)
	Frequency Setting	Analog input:0 to 10V, 0 to 20mA can be selected; Digital input: Input using the setting dial of the operation panel or RS485or UP/DOWN.
	Multi-speed	Six multifunction input terminals, 15 section speed can be set
	Automatic voltage regulation	Automatic voltage regulation function can be selected
	Counter	Built-in 2 group of counters
Protection/ Warning Function	Overload	150%, 60second (Constant torque)
	Over Voltage	Over voltage protection can be set.
	Under Voltage	Under voltage protection can be set.
	Other Protections	Overheat ,output shortcircuit, over current, and parameter lock and so on.
Environment	Ambient Temperature	-10°C to 40°C (non-freezing)
	Ambient Humidity	Max. 95% (non-condensing)
	Altitude	Lower than 1000m
	Vibration	Max. 0.5G
Structure	Cooling Mode	Forced air cooling
	Protective Structure	IP 20
Installation	Mode	Wall Mounted

Specification

Unit: mm

Model	Rate output Power (kw)	Capacity (KVA)	Output Current (A)	Overload capacity (60s)(A)	Applicable motor (KW)
1PH AC220V ±15% 50/60Hz					
SS900-0.4	0.4	1	2.2	3.75	0.4
SS900-0.75	0.75	2	5	7.5	0.75
SS900-1.5	1.5	2.8	7	10.5	1.5
3PH AC380V ±15% 50/60Hz					
SS900-0.75	0.75	2.2	2.7	4.05	0.75
SS900-1.5	1.5	3.2	4	6	1.5
SS900-2.2	2.2	4	5	7.5	2.2
SS900-3.7	3.7	6.8	8.6	12.9	3.7
SS900-5.5	5.5	10	12.5	18.75	5.5
SS900-7.5	7.5	14	17.5	21	7.5
SS900-11	11	19	24	36	11
SS900-15	15	26	33	45	15
SS900-18.5	18.5	32	40	60	18.5
SS900-22	22	37	47	70.5	22
SS900-30	30	52	65	97.5	30
SS900-37	37	64	80	120	37

Dimension

Unit: mm

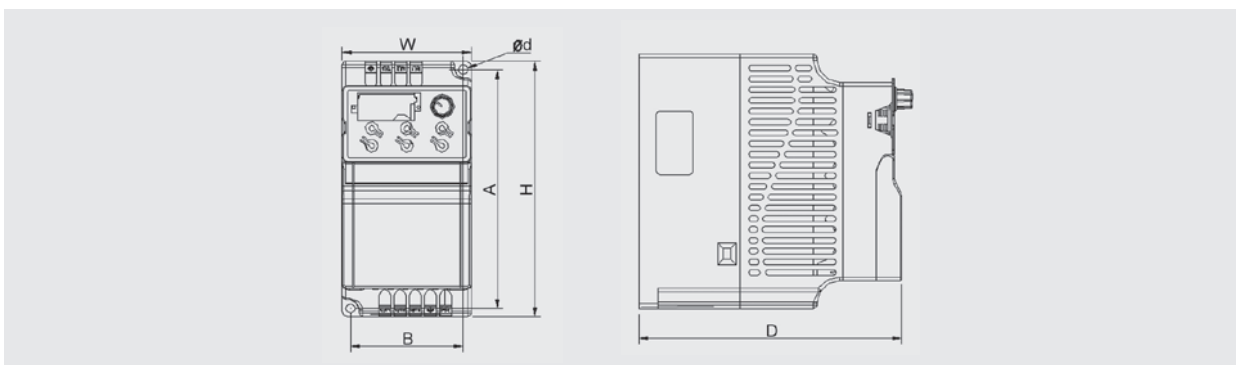

Model	Outline dimension (mm)			Installation size (mm)		
	W	H	D	A	B	Φd
SS900-0.4 -- SS900-1.5	72.0	142.0	152	132.7	62.7	5
SS900-2.2 -- SS900-3.7	100.0	183.0	143	173.0	90.0	5
SS900-5.5 -- SS900-7.5	130.0	260.0	184	250	120	5
SS900-0.4 -- SS900-2.2	72.0	142.0	152.0	132.7	62.7	5
SS900-3.7 SS900-5.5	100.0	183.0	143	173.0	90.0	5
SS900-7.5 SS900-11	130.0	260.0	184	250	120	5
SS900-15 SS900-18.5 SS900-22	195.0	280.0	179	266.0	182.5	7
SS900-30 SS900-37	245	425	193	410.0	180.0	7

SS900 S Typical Wiring Diagram

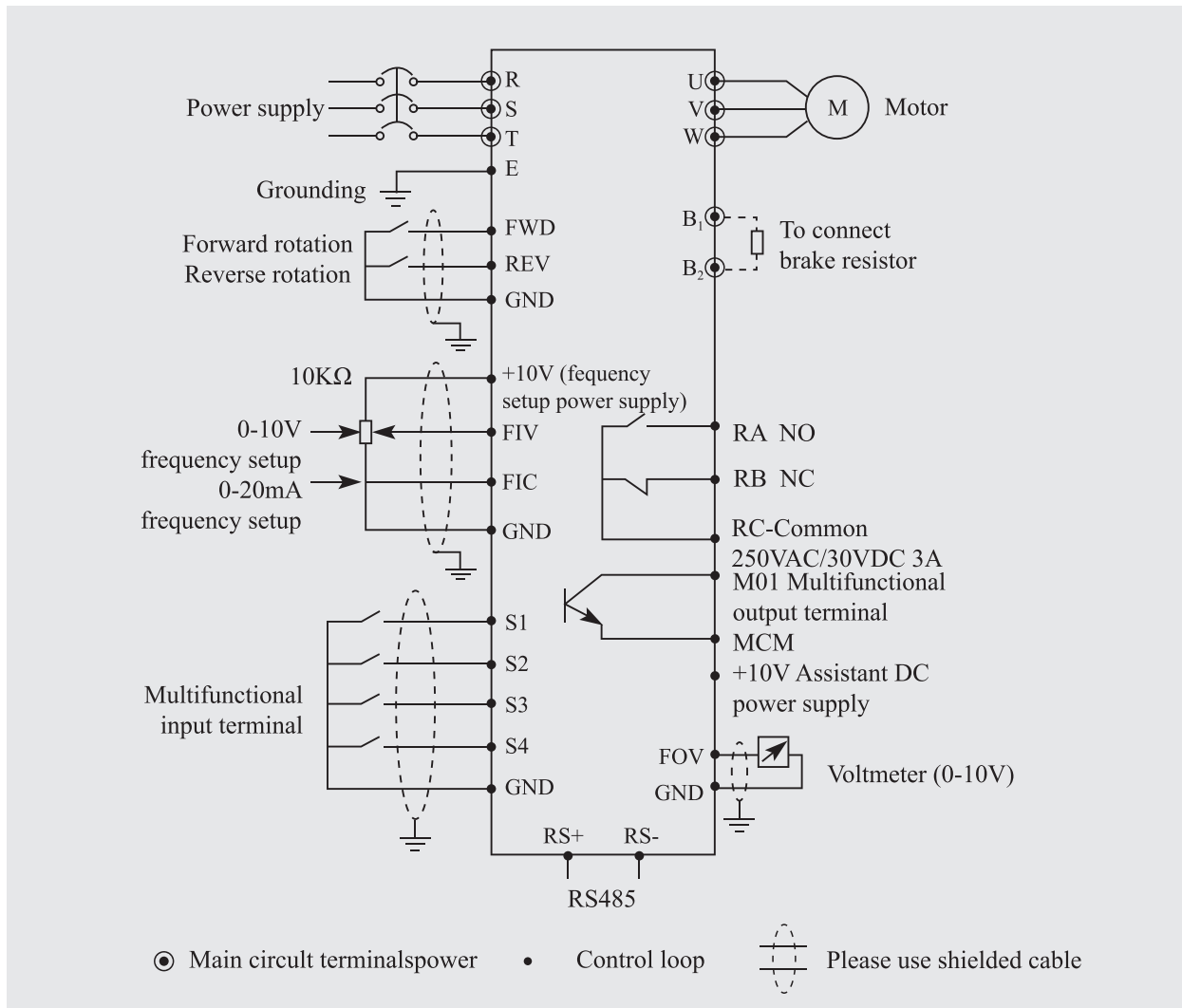

Target Market of SS900 S Series Inverter

Food machinery-Feeder, mixer, bag filling machines, pastry forming machine...

Woodworking Machinery-Polishing machine, grinding machine, carving machine...

Textile Machinery-winding machine, fabric inspection machine...

Packaging Machinery-Liquid filling machine, pharmaceutical filling machine...

Other: Stone cutting machine...

Blowing machine, Water-pump-housetop/a fan to fill and exhaust gas, small

Pump for water supply

Printing equipment-offset

Conveyor belt-Small conveyor belt, common conveyor belt

Feeding equipment-Tool machine, winding machines, weaving machines equipment

Rubber and plastic industry-Sealing machine, various types of small machine

General business-Common household, air conditioning, automatic door



SZ900 E Series-Mini Inverter

vector control with open loop

Compact Size Design, Small Appearance, Easy to Operate.

Product Specification

Item	SZ900 E
Control mode	Sensorless flux vector control (SFVC) Voltage/Frequency (V/F) control
Maximum frequency	Vector control: 0–320 Hz V/F control: 0–3200Hz
Carrier frequency	1–16 kHz The carrier frequency is automatically adjusted based on the load features.
Input frequency resolution	Digital setting: 0.01 Hz Analog setting: maximum frequency x 0.025%
Startup torque	G type: 0.5 Hz/150% (SFVC) P type: 0.5 Hz/100%
Speed range	1:100 (SFVC)
Speed stability accuracy	± 0.5% (SFVC)
Torque control accuracy	± 5% (CLVC)
Overload capacity	G type: 60s for 150% of the rated current, 3s for 180% of the rated current. P type: 60s for 120% of the rated current, 3s for 150% of the rated current.
Torque boost	Fixed boost Customized boost 0.1%–30.0%
V/F curve	Straight-line V/F curve Multi-point V/F curve N-power V/F curve (1.2-power, 1.4-power, 1.6-power, 1.8-power, square)
V/F separation	Two types: complete separation; half separation
Ramp mode	Straight-line ramp S-curve ramp Four groups of acceleration/deceleration time with the range of 0.0–6500.0s
DC braking	DC braking frequency: 0.00 Hz to maximum frequency Braking time: 0.0–100.0s Braking action current value: 0.0%–100.0%
JOG control	JOG frequency range: 0.00–50.00 Hz JOG acceleration/deceleration time: 0.0–6500.0s
Onboard multiple preset speeds	It implements up to 16 speeds via the simple PLC function or combination of X terminal states
Onboard PID	It realizes process-controlled closed loop control system easily.
Auto voltage regulation (AVR)	It can keep constant output voltage automatically when the mains voltage changes.
Overvoltage/Overcurrent stall control	The current and voltage are limited automatically during the running process so as to avoid frequent tripping due to overvoltage/over current.
Torque limit and control	It can limit the torque automatically and prevent frequent over current tripping during the running process.
Instantaneous stop doesn't stop	The load feedback energy compensates the voltage reduction so that the AC drive can continue to run for a short time.
Rapid current limit	It helps to avoid frequent over current faults of the AC drive.
High performance	Control of asynchronous motor is implemented through the high-performance current vector control technology.
Timing control	Time range: 0.0–6500.0 minutes

Standard functions

Item		SZ900 E
Standard functions	Communication methods	RS485
	Running command channel	Given by the panel, control terminals, Serial communication port, can be switched by many ways
	Frequency source	10 kinds of frequency source, given by Digital analog voltage, analog current, Pulse, serial port. can be switched by many ways
	Auxiliary frequency source	10 kinds of Frequency source, can easily realize Micro adjustment, frequency Synthesizer
Input and output	Input terminals	6 digital input terminals, one of which supports up to 100 kHz high-speed pulse input. 2 analog input terminal, one of which only supports 0–10 V voltage input and the other supports 0–10 V voltage input or 4–20 mA current input.
	Output terminal	1 digital output terminal 1 relay output terminal 1 analog output terminal :that supports 0–20 mA current output or 0–10 V voltage output
operation on the operation panel	LED display	It displays the parameters.
	Key locking and function selection	It can lock the keys partially or completely and define the function range of some keys so as to prevent mis-function.
	Protection mode	Motor short-circuit detection at power-on, output phase loss protection, over-current protection, over-voltage protection, under voltage protection, overheat protection and overload protection.
Environment	Installation location	Indoor, avoid direct sunlight, dust, corrosive gas, combustible gas, oil smoke, vapour, drip or salt.
	Altitude	Lower than 1000m (Lower the grades when using higher than 1000m)
	Ambient temperature	-10°C ~40°C (Lower the grades if the ambient temperature is between 40°C and 50°C)
	Humidity	Less than 95%RH, without condensing
	Vibration	Less than 5.9 m/s ² (0.6 g)
	Storage temperature	-20°C~60°C

Specification

Unit: mm

Model	Rate output Power (kw)	Rated Input Current (A)	Rated Output Current (A)	Applicable motor (KW)
1PH AC220V ±15% 50/60Hz				
SZ900-0.4	0.4	5.4	2.4	0.4
SZ900-0.75	0.75	7.2	4.5	0.75
SZ900-1.5	1.5	10	7.0	1.5
SZ900-3.7	3.7	16	10.0	3.7
SZ900-5.5	5.5	21	20	5.5
SZ900-7.5	7.5	31	30	7.5
3PH AC380V ±15% 50/60Hz				
SZ900-0.4	0.4	3.4	1.2	0.4
SZ900-0.75	0.75	3.8	2.5	0.75
SZ900-1.5	1.5	5	3.7	1.5
SZ900-2.2	2.2	5.8	5.0	2.2
SZ900-3.7/5.5	3.7/5.5	10.0/15.0	9.0/13.0	3.7/5.5
SZ900-5.5	5.5	15	13	5.5
SZ900-7.5	7.5	20	17	7.5
SZ900-11/15	11/15	26/35	25/32	11/15
SZ900-15/18.5	15/18.5	35/38	32/37	15/18.5

Model	Rate output Power (kw)	Rated Input Current (A)	Rated Output Current (A)	Applicable motor (KW)
SZ900-18.5/22	18.5/22	38/46	37/45	18.5/22
SZ900-22/30	22/30	46/62	45/60	22/30
SZ900-30/37	30/37	62/76	60/75	30/37
SZ900-37/45	37/45	76/90	75/90	37/45
SZ900-45/55	45/55	90/105	90/110	45/55
SZ900-55	55	105	110	55
SZ900-75	75	140	150	75
SZ900-75/90	75/90	140/160	150/176	75/90
SZ900-90/110	90/110	160/210	176/210	90/110
SZ900-110/132	110/132	210/240	210/253	110/132
SZ900-132/160	132/160	240/290	253/300	132/160
SZ900-160/185	160/185	290/330	300/340	160/185

Dimension

Unit: mm

(1)0.4--22kW

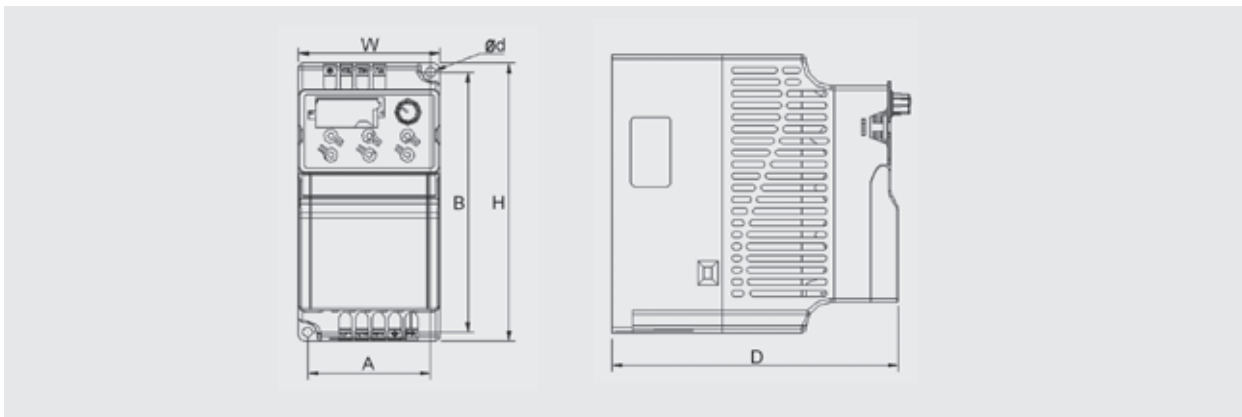

(2)30--160kW

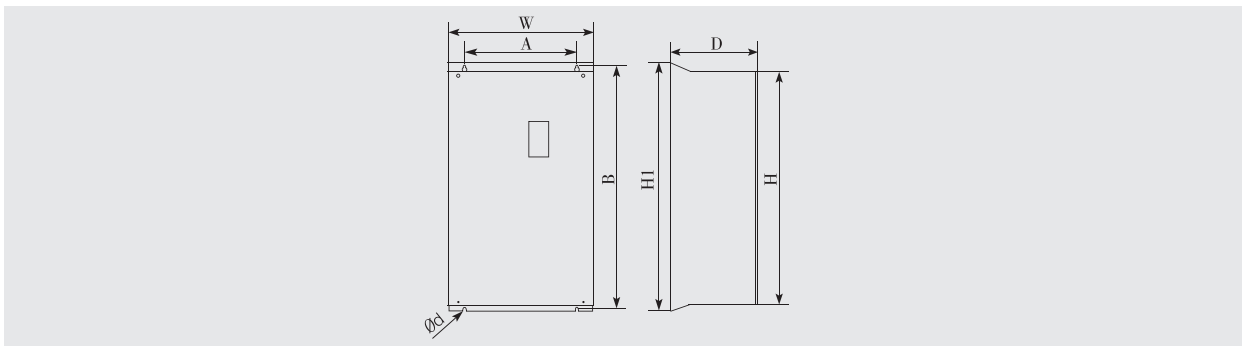

Model	Outline dimension (mm)				Installation size (mm)		
	W	H	H1	D	A	B	Φd
SZ900-0.4 -- SZ900-1.5	72	142		152	62.7	132.7	5
SZ900-2.2 -- SZ900-3.7	100	183		143	90	173	5
SZ900-5.5 -- SZ900-7.5	130	260		184	120	250	5
SZ900-0.4 -- SZ900-2.2	72	142		152	62.7	132.7	5
SZ900-3.7 -- SZ900-5.5	100	183		143	90	173	5

Model	Outline dimension (mm)				Installation size (mm)		
	W	H	H1	D	A	B	Φd
SZ900-7.5 SZ900-11	130	260		184	120	250	5
SZ900-15/18.5 SZ900-22/30	195	280		179	182.5	266	7
SZ900-30/37 SZ900-37/45	245	390	425	193	180	410	7
SZ900-45/55 SZ900-55/75	300	500	540	252	200	522	9
SZ900-75/90	338	546	576	256.5	270	560	9
SZ900-90/110 SZ900-110/132	338	550	580	300	270	564	9
SZ900-132/160 SZ900-160/185	400	675	715	310	320	695	11

SZ900 E Typical Wiring Diagram

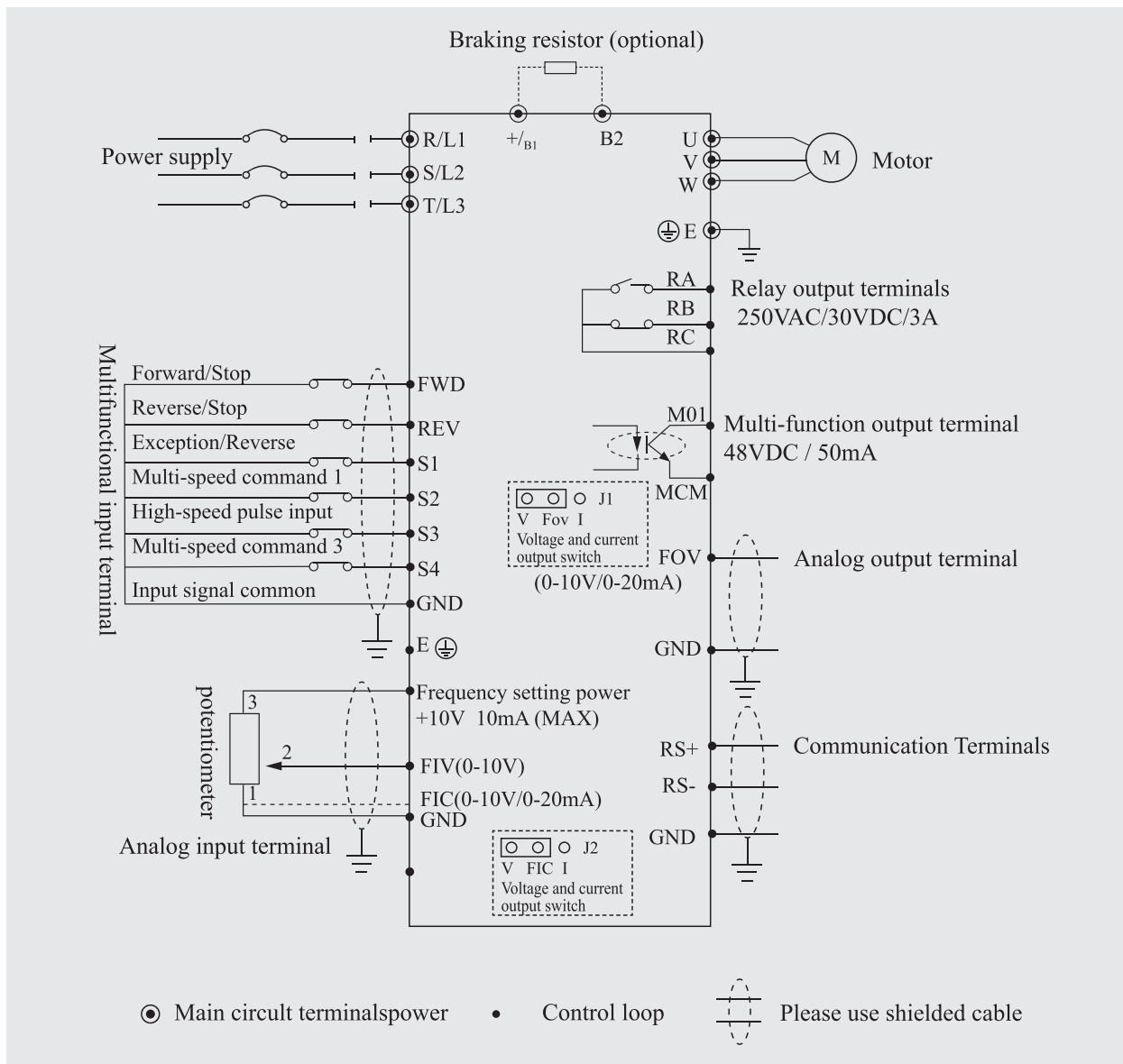

SS2100 S IP65 series Intelligent Frequency Inverter



Product Specification

Items		SS2100 S
Power Supply	Rated voltage, Frequency	1PH 220V50/60Hz 3PH 380V50/60Hz
	Voltage Range	220V: 170--240V 380V: 330--440V
Output	Voltage Range	220V: 0--220V 380V: 0--380V
	Frequency Range	0.10~400.00Hz
Control method		V/F control, Space vector control.
Indication		Operating status/Alarm definition/interactive guidance: eg, frequency setting, the output frequency/current, DC bus voltage, the temperature and so on.
Control Specifications	Output Frequency Range	0.10Hz~400.00Hz
	Frequency Setting Resolution	Digital input : 0.1 Hz, analog input: 0.1% of maximum output frequency
	Output Frequency Accuracy	0.1Hz
	V/F Control	Setting V/F curve to satisfy various load requirements.
	Torque Control	Auto increase: auto raise torque by loading condition; Manual increase:enable to set 0.0~20.0% of raising torque.
	Multifunctional Input Terminal	Six multi-function input terminals, realizing functions including fifteen section speed control, program running, four-section acceleration/ deceleration speed switch, UP/DOWN function and emergency stop and other functions
	Multifunctional Output Terminal	2 multi-function output terminals for displaying of running, zerospeed, counter, external abnormality, program operation and other information and warnings.
	Acceleration/deceleration Time Setting	0~999.9s acceleration/deceleration time can be set individually.
Other Functions	PID Control	Built-in PID control
	RS485	Standard RS485 communication function (MODBUS) Analog input:0 to 10V, 0 to 20mA can be selected;
	Frequency Setting	Digital input: Input using the setting dial of the operation panel or RS485or UP/DOWN.
	Multi-speed	Six multifunction input terminals, 15 section speed can be set
	Automatic voltage regulation Counter	Automatic voltage regulation function can be selected Built-in 2 group of counters

Items	SS2100 S	
Protection/Warning Function	Overload	150%, 60second (Constant torque)
	Over Voltage	Over voltage protection can be set.
	Under Voltage	Under voltage protection can be set.
	Other Protections	Overheat ,output shortcircuit, over current, and parameter lock and so on.
Environment	Ambient Temperature	-10°C to 40°C (non-freezing)
	Ambient Humidity	Max. 95% (non-condensing)
	Altitude	Lower than 1000m
	Vibration	Max. 0.5G
Structure	Cooling Mode	Forced air cooling or Natural cooling
	Protective Structure	IP65
Installation	Mode	Wall Mounted

Specification

Unit: mm

Model	Suitable Motor	Output Current	Assembly Dimension(mm)					
			W	H	D	A	B	b
SS2100-0.75	0.75KW	5						
SS2100-1.5	1.5KW	7	188	122	134	105	178	M4
SS2100-2.2	2.2KW	11						
SS2100-0.75	0.75KW	2.7						
SS2100-1.5	1.5KW	4	188	122	134	105	178	M4
SS2100-2.2	2.2KW	5						
SS2100-3.7	3.7KW	8.6						
SS2100-5.5	5.5KW	12.5						
SS2100-7.5	7.5KW	17.5	235	154	179	129	225	M4
SS2100-11	11KW	24						

Dimension

Unit: mm

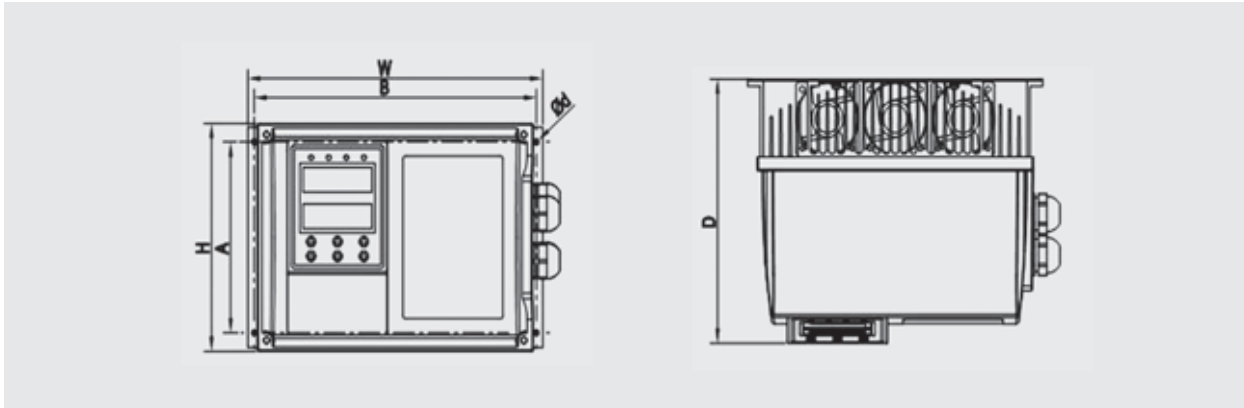

SS2100 S Typical Wiring Diagram

(1) 0.75--2.2kW

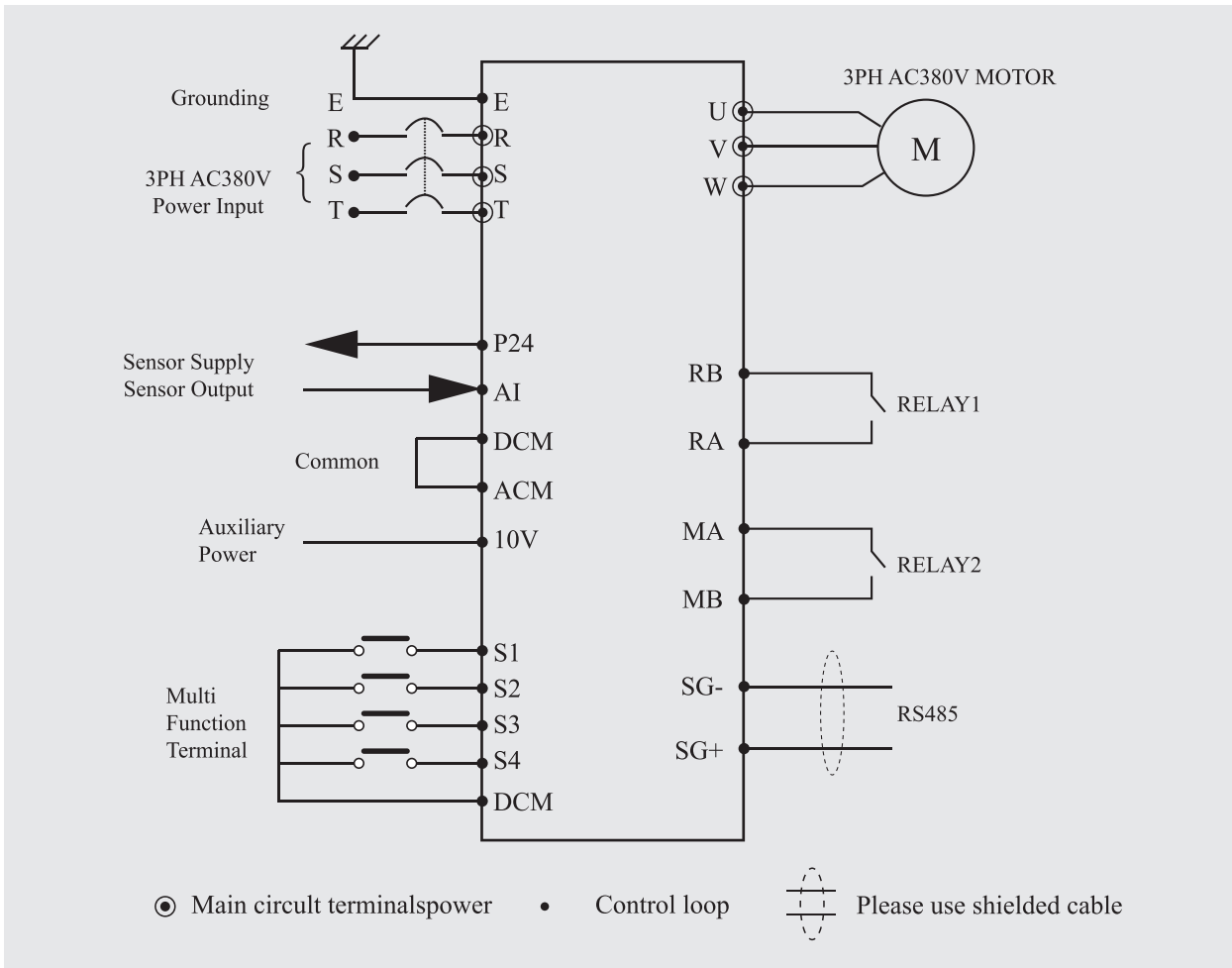

(2) 3.7--11kW

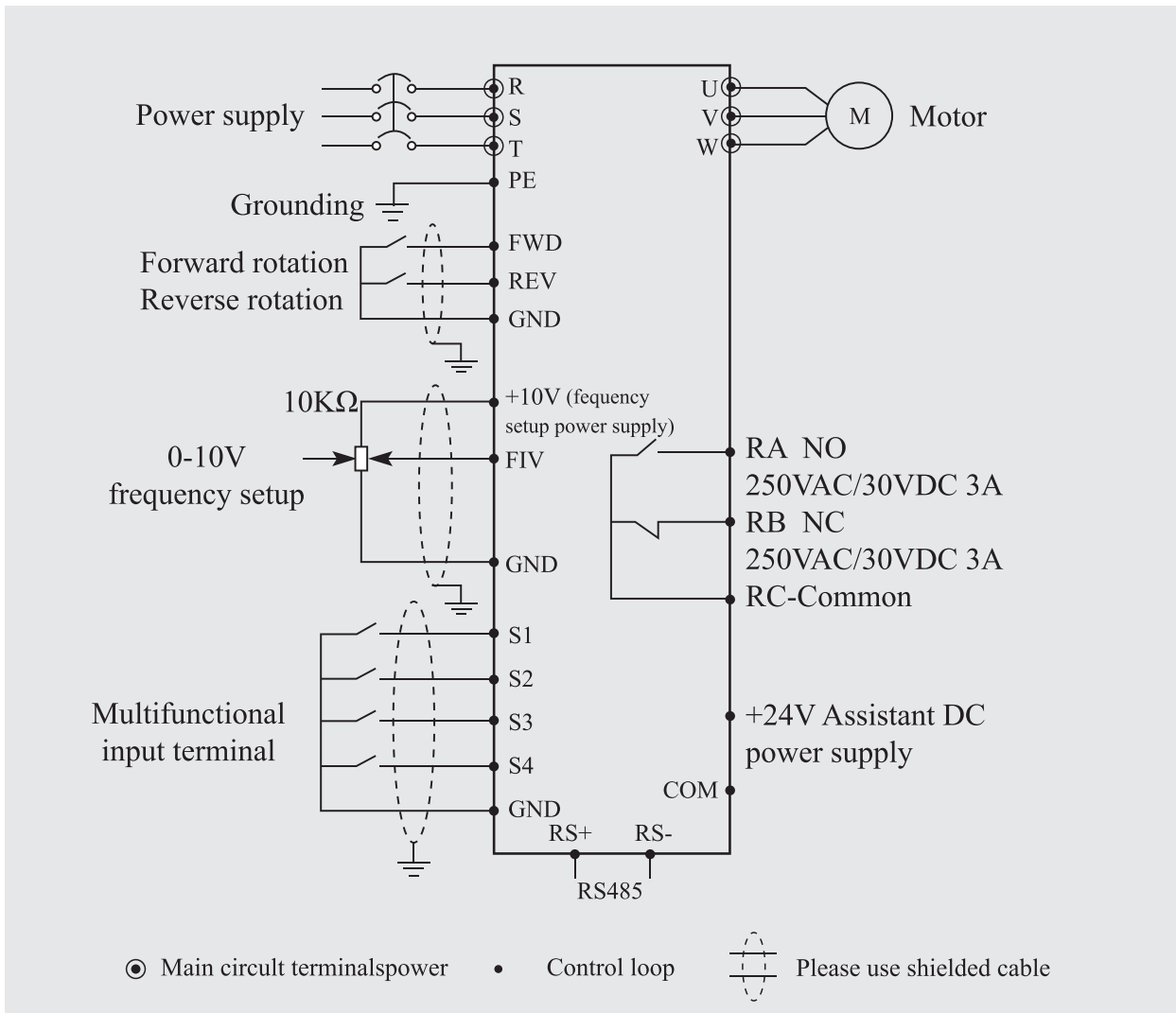

Advantage

Big savings on installation: With a built in RFI filter, the SS2100S IP65 inverter can be positioned close to the motor which cuts the cost of shielded motor cables. Choose the version with integrated insulator to simplify your external connections.

Big performance: The SS2100S IP65 is a modern sensorless vector inverter with 200% overload capacity, a wide range of supply and fieldbus options, and excellent I/O.

Big advantages of easy handling: The SS2100S IP65 inverters integrate the EPM memory module—a simple plug in chip that stores all the drive settings. The EPM module can be programmed off-line and the settings transferred from drive to drive in seconds. In the unlikely event that a drive fails, the EPM guarantees you minimum downtime.

SAMT[®]



Specialised Air Motors and Transmission

TONSON[®]

New South Wales

Head Office

Unit 19/5 Lyn Parade

Prestons NSW 2170

Ph: (02) 9607 4100

Fax: (02) 9607 4200

Website: www.tonson-motor.com.au

Email: sales@samt.com.au