



Factory 19 / 5 Lyn Parade

Prestons NSW 2170

Ph: 02 9607 4100

Fax: 02 9607 4200

Website: www.tonson-motor.com.au

Email: sales@samt.com.au



HD71 AC Drives



Performance Features

- Advanced motor control algorithm
- High performance open loop vector control
- Optimal V/F mode
- Excellent ramp slope control
- Fast autotune (less than one minute)
- Overload: 150% rated output current, one minute
- Low frequency torque:
0.5Hz: 100% rated torque
1Hz: 150% rated torque

Main Hardware Features

- Dual CPU processing, more precise control
- 4th generation IGBT
- Optional internal brake unit
- Internal EMC filter with breakpoint design
- PCBA coating process
- Unique control terminals: simple electronic switch set to complete the conversion between source and sink of I/O terminals
- Reference (current) loose, trip or not could be selected
- IGBT thermal design

Main Function Features

- Simple parameters, easy to use
- Low DC voltage operation mode (400V)
- AVR
- Switching frequency automatic adjustment
- Catch spinning function
- DC injection braking
- Jump frequency control function
- Powerful electronic potentiometer function
- Standard MODBUS-RTU
- The comprehensive protection function: fast protection for output shortage, over current, over load, over voltage, under voltage, phase loss, over heat (heatsink and junction), external trip, etc.
- 8 preset speeds (decided by control terminals)

Model Reference

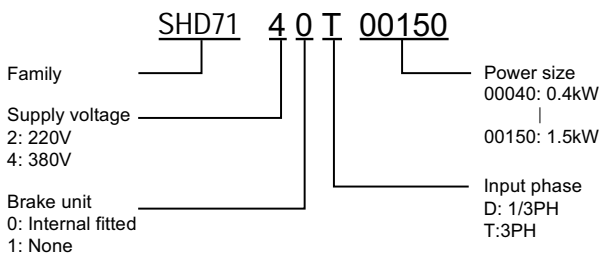

Mounting dimensions diagram

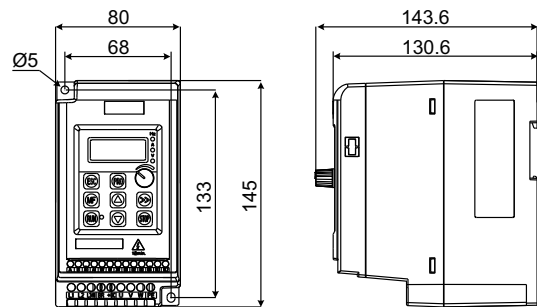

220V - 240V Rating Data

Power supply: 220Vac~240Vac, 50Hz/60Hz, single/three phase

Model name	Motor power (kW)	Rated input current (A)	Rated output current (A)	Drive power size (kVA)
		1/3PH		
SHD7120/1D00040	0.4	5.8/3.5	2.8	1.1
SHD7120/1D00075	0.75	11.3/6.3	4.5	1.7
SHD7120/1D00100	1.1	12.3/7.5	5.5	2.1
SHD7120/1D00150	1.5	20.5/11.3	8	3.0

380V - 480V Rating Data

Power supply: 380Vac~480Vac, 50Hz/60Hz, three phase

Model name	Motor power (kW)	Rated input current (A)	Rated output current (A)	Drive power size (kVA)
SHD7140/1D00040	0.4	2.8	1.5	1.0
SHD7140/1D00075	0.75	3.6	2.5	1.7
SHD7140/1D00150	1.5	5.7	4.2	2.8

Technical specifications

Input power	Input voltage U_{in}	200V (-10%)~240V (+10%) 1/3PH 380V (-10%)~480V (+10%) 3PH
	Input frequency	50Hz/60Hz
	Maximum supply imbalance	≤3%
Power output	Output voltage	0V~ U_{in}
	Output frequency	0Hz~300Hz
Main performance function	Voltage control	V/F, open loop vector control
	Switching frequency	1kHz~15kHz
	Adjust speed range	Open loop vector -1:100, V/F mode -1:50
	Start torque	0.5Hz: 100% rated torque, 1Hz: 150% rated torque
	Torque accuracy	7%
	Torque ripple	≤2%
	Speed accuracy	≤1% n_n (Under the rated operating conditions)
	Reference resolution	Digit- 0.01Hz, Analogue- 0.1%×Maximum frequency
	Accel. & Decel. rate	0.1s~3600s
	Voltage boost	0.1%~30.0%
	Overload	150% rated output current, 1 minute
	V/F	4 types: V/F (user can program) and ramp (2.0 power, 1.7 power, 1.2 power)
	DC braking	Injection frequency: 0.0%~20.0% maximum frequency Injection current: 0.0%~300.0% rated current Injection time: 0.00s~60.00s
	Dynamic braking	Brake rate: 0.0%~100.0%
	Jog	Jog frequency: 0.00Hz~50.00Hz Jog interval time: 0.1s~60.0s
	Preset	8 preset speeds (decided by control terminals)
AVR	Maintain the rated output voltage when the input power supply voltage changed.	
Special performance function	Internal PID	Easy to form a closed-loop control system
Control terminals	Reference source	Digit: keypad, motorized pot (E-Pot), PID, comms. Analogue: AI: 0V 10V, 0(4) mA~20mA; keypad potentiometer
	Operation mode	Keypad, control terminal, serial comms.
	Digital input terminals	DI1~DI4: programmable terminals
	Analogue input terminal	AI: programmable terminal, 0V 10V, 0(4) mA~20mA, can be used as digital input terminal by programming
	Analogue output terminal	AO: programmable terminal, 0V 10V, can be used as digital output terminal by programming
	Status relay	1 programmable relay, contactor data: AC250V/2A (COS ϕ =1) ; AC250V/1A (COS ϕ =0.4) ; DC30V/1A
Comms.	Connectors	Terminals A, B
	Protocol	Modbus RTU
Environment	Altitude	1000m rated; 1000m~3000m, 1% current derating
	Operating temperature	-10°C~+40°C
	Maximum humidity	<90%RH, no-condensing
	Vibration	<5.9m/s ² (0.6g)
	Storage temperature	-40°C~+70°C
	Running environment	Indoor, non-flammable, no corrosive gasses, no contamination with electrically conductive material, avoid dust which may restrict the fan.
Protection		Output shortage, over current, over load, over voltage, under Voltage, phase loss, over heat (heatsink and junction), external trip, etc.
Efficiency		≥89%
Mounting method		Surface mounting, DIN rail
Enclosure		IP00, IP20 (by adding optional device)
Cooling method		0.4kW model is nature cool, others are forced air cool

SAMT[®]



Specialised Air Motors and Transmission

TONSON[®]

New South Wales

Head Office

Unit 19/5 Lyn Parade

Prestons NSW 2170

Ph: (02) 9607 4100

Fax: (02) 9607 4200

Website: www.tonson-motor.com.au

Email: sales@samt.com.au