



Specialised Air Motors and Transmission

TONSON®

New South Wales

HEAD OFFICE

Unit 19/5 Lyn Parade

Prestons NSW 2170

Ph: (02) 9607 4100

Fax: (02) 9600 8882

Web: www.tonson-motor.com.au

Email: sales@samt.com.au



Vane Air Motors



Table of Contents

About us	1
Features and Applications.....	2
Specifications	3
Air Gearmotors and Brakes.....	5
Order Code For Vane Air Motors	5
Accessories.....	6
Dimensions for V1 and VA1 Series.....	7
Performance Graphs for V1 Series.....	8
Performance Graphs for VA1 Series.....	9
Dimensions for V2 Series.....	10
Performance Graphs for V2 Series.....	11
Dimensions for V4 Series.....	12
Performance Graphs for V4 Series.....	13
Dimensions for V6 Series.....	14
Performance Graphs for V6 Series.....	15
Dimensions for V8 Series.....	16
Performance Graphs for V8 Series.....	17
Dimensions for V16 Series.....	18
Performance Graphs for V16 Series.....	19



Specialised Air Motors & Transmission (SAMT) - incorporating TONSON - was founded in 1966 and provides efficient solutions and equipment to all major industries including mining, chemical, food, paper, plastic, power transmission, manufacturing and pharmaceutical.

Our commitment to you is best service, quick lead times and very competitive prices.

Innovation & Quality

Specialised Air Motors & Transmission is committed to providing clever solutions for all hazardous environments and continues to develop smart ways to meet requirements from all different industries; our products meet CE standards ISO9002, ISO9001 and patents are registered globally including USA, Taiwan and China.

Unlike other conventional methods our products mainly use air instead of electricity as the source of power. This eliminates the chance of electricity shock and fire, which are the most crucial factors for industries involved in chemical, flammable or volatile contents.

Specialised Air Motors & Transmission products include air/electric motors, air/electric mixers and air fans which are engineered to meet the highest standards featuring 100% explosion-proof, low air consumption, light weight, high torque, reversible step less speed control, easy maintenance and various mounting methods. And can be used in very harsh conditions such as humidity, high temperature and flammable environments.

Products & Services

SAMT's other popular products include Pressure Tanks up to 200L (with and without integrated mixer), spray guns, pneumatic double diaphragm pumps, vertical pumps, magic drum carriers, non-spark drum openers, propellers, plus many more exciting and innovative products.

We also have the technical capability and expertise to provide complete power transmission solutions to meet your specific requirements, including full engineering assistance with design, selection and site installation. We also specialise in the supply of all types of Industrial gearboxes including Helical, Worm, Bevel-Helical, Bevel, screw jacks and planetary. All are interchangeable with other internationally recognised brands.

SAMT can also customise any product to suit your specific requirements and will investigate the possibilities of developing new products to satisfy your special specifications.



Features and applications

Vane Air Motor features include:

- 100% Explosion-proof
- Stalling Safety
- Step less Speed Control
- Never Burn Out
- Self-Sealing & Cool Running
- Smooth Start
- Mounting Flexibility (IEC, Nema, Face and Foot)
- All Plane Operation
- Toleration of Environment

Vane Air Motor applications are unlimited including:

- Hoist / Winches
- Pump Drives
- Automation Devices
- Hose Reels
- Conveyor Drives
- Choppers / Grinders
- Turntables
- Mixing Equipment
- Food / Pharmacy Packaging

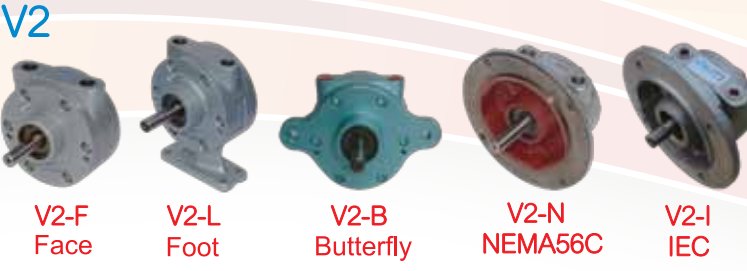
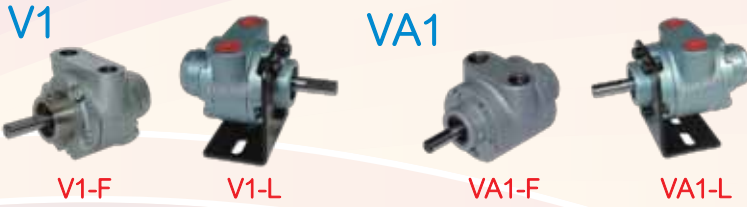

MOUNT

Mass(kg)	V1	VA1	V2	V4	V6	V8	V16
F-Face	0.8	1	2.2	3.9	7.6	10.4	32.94
L-Foot	0.9	1.1	3.3	4.3	7.9	11	32.9
B-Butterfly	V2		3	4.1	7.8	10.5	(LN)36
NEMA56C	IEC#72D71C		3.8	5.1	8.4	12	32.9
IEC#72D71	4kg		4.3	5.3	8.8	13	36

SPECIFICATION

Series	Gear Ratio	Performance at Maximum Speed						Max. Torque						
		Power		Torque		Speed	Air Com.		Spd.		Torque			
		HP	kW	N-m	lb-in	RPM	l/min	CFM	RPM	N-m	lb-in			
V1	1:1	0.5	0.3	0.31	2.75	10000	590	21	650	0.65	5.75			
	3.5:1	0.4	0.3	0.82	7.26	2800			190	0.9	7.97			
	15:1	0.4	0.3	4.07	36	666			30	8.15	72			
	43:1	0.4	0.3	11.30	100	232			10	12	106			
	150:1	0.2	0.1	19.40	172	66			5	21	186			
VA1	1:1	0.50	0.4	0.60	5.31	6000	760	27	500	0.68	6.01			
	3.5:1	0.45	0.3	1.80	15.9	1700			135	2	18			
	15:1	0.46	0.3	8.13	72	400			30	8.9	71			
	43:1	0.41	0.3	21.0	186	139			10	23	204			
	150:1	0.20	0.2	36.0	319	40			3	40	354			
V2	1:1	0.9	0.7	2.20	19.5	3000	900	32	350	3.05	27			
	3:1	0.8	0.6	5.6	49.6	1000			100	7.6	67			
	5:1	0.8	0.6	9	79.7	600			60	12	106			
	10:1	0.74	0.6	17.6	156	300			30	24	212			
	15:1	0.70	0.5	25.0	221	200			20	34	301			
	20:1	0.65	0.5	31.0	274	150			15	42	372			
	30:1	0.58	0.4	41.0	363	100			10	55	487			
	40:1	0.51	0.4	48.6	430	75			7	66	584			
	60:1	0.47	0.4	67.0	593	50			5	89	788			
	80:1	0.45	0.3	85	752	37.5			3.5	112	991			
	100:1	0.44	0.3	106	934	30			3	139	1230			
	120:1	0.44	0.3	127	1121	25			2.5	167	1480			
	140:1	0.44	0.3	148	1308	21			2	195	1726			
	V4	1:1	1.7	1.3	4.10	36			3000	1620	57	300	6.3	56
		3:1	1.3	0.9	9.20	81			1000			100	14	124
5:1		1.3	0.9	15.4	136	600	60	24	212					
10:1		1.3	0.9	31	274	300	30	48	425					
15:1		1.3	0.9	45.2	400	200	20	72	640					
20:1		1.2	0.9	55.0	487	150	15	84	740					
30:1		1.1	0.8	75.5	668	100	10	116	1027					
40:1		1	0.7	90	800	75	7	142	1255					
50:1		0.9	0.7	105	929	60	6	161	1425					
60:1		0.8	0.6	118	1040	50	5	185	1640					
70:1		0.8	0.6	138	1220	42.9	4	207	1832					
80:1		0.8	0.6	158	1396	37.5	3.5	237	2097					
100:1		0.8	0.6	205	1814	30	3	308	2726					
120:1		0.8	0.6	237	2093	25	2.5	355	3142					
140:1		0.8	0.6	285	2522	21	2	428	3788					
V6	1:1	4	3	10	89	3000	3620	128	300	13	115			
	3:1	3.5	2.6	25	221	1000			100	33	292			
	5:1	3.4	2.5	40	354	600			60	52	460			
	10:1	3.4	2.5	81	720	300			30	107	950			
	15:1	3	2.2	105	929	200			20	137	1212			
	20:1	2.7	2	124	1100	150			15	175	1550			
	30:1	2.4	1.8	169	1496	100			10	220	1947			
	40:1	2.1	1.6	195	1725	75			8	283	2500			
	50:1	2	1.5	238	2106	60			6	309	2735			
	60:1	2	1.5	290	2567	50			5	377	3336			
	80:1	2	1.5	380	3363	37.5			3.8	646	5717			
	100:1	1.9	1.4	446	3947	30			3	580	5133			
	120:1	1.9	1.4	540	4779	25			2.5	703	6222			
	150:1	1.9	1.4	675	5974	20			2	878	7770			
	200:1	1.8	1.3	900	7965	15			1.8	1170	10355			
360:1	1.8	1.3	1600	14160	8	1.7	2080	18408						
V8	1:1	5.3	3.9	15	132	2500	4955	175	300	21	185			
	3:1	4.6	3.5	40	354	833			100	54	478			
	5:1	4.5	3.3	63	558	500			60	85	752			
	10:1	4.5	3.3	127	1124	250			30	171	1513			
	20:1	3.7	2.8	209	1850	125			15	288	2550			
	30:1	3.1	2.3	266	2354	83			10	360	3186			
	40:1	2.7	2	309	2735	63			8	417	3690			
	50:1	2.6	2	375	3319	50			6	506	4478			
	60:1	2.5	1.9	427	3779	42			5	576	5098			
	80:1	2.5	1.9	560	4956	31.3			3.8	755	6682			
	100:1	2.5	1.9	700	6195	25			3	943	8346			
	125:1	2.5	1.9	880	7788	20			2.4	1161	10275			
	140:1	2.5	1.9	980	8673	17.9			2.1	1293	11443			
	180:1	2.5	1.9	1269	11231	13.9			1.7	1675	14824			
	V16	1:1	9.5	7.1	34	300			2000	7787	275	300	43	380
3:1		7	5.2	75	664	666	100	92.3	817					
5:1		6.7	5	116	1027	400	60	143	1266					
10:1		6.7	5	238	2106	200	30	293	2593					
20:1		6.5	4.9	472	4177	100	15	585	5177					
30:1		5.5	4.1	592	5239	66	10	728	6443					
40:1		5.6	3.4	650	5753	50	7.5	800	7080					
60:1		4.6	3.4	975	8629	33.3	4.9	1200	10620					
80:1		4.6	3.4	1300	11505	25	3.8	1599	14151					
100:1		4.3	3.2	1530	13541	20	3	1882	16656					
120:1		4.3	3.2	1830	16196	16.7	2.5	2250	19913					

With Gearbox Reducer



V2-LG V4-FG60 V4-LG60 V6-FG10 V8-LG20 V8-LG50 V8-LG20 V16-LG30

With Compact Reducer

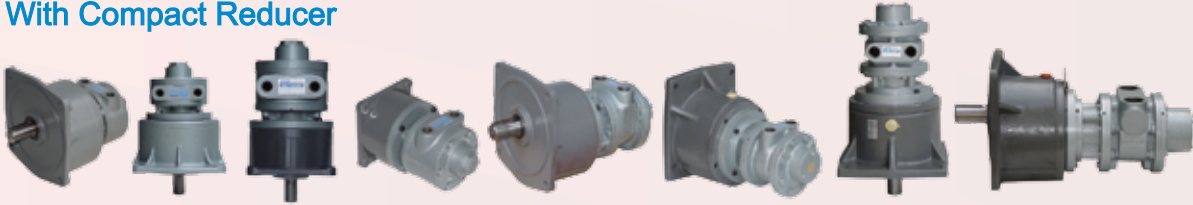

V2-FGS5 V2-FGS V4-FGS3 V4-FGS3 V6-FGS5 V8-FGS10 V8-FGS10 V16-FGS5

Refer to our Gearbox Division / Brochure for extensive range of gearboxes available.

With Worm Gearbox Reducer



V4-LWG50 V6-FBWG V8-LWG20

With Planetary Gearbox Reducer



V6-FPG V6-LPG V8-LPG V1-FG 3.5 15 43 150

With Hand Control Valve



V4-LBHV V4-LBG40R V6-LG20R V8-FGHCV V16-LHCV

With Remote Control



V8-FBRCV V8-LRCV

With Brake



V2-FB(IEC) V4-FB V4-FBIEC V6-LB V8-FB V16-FB V16-FBG40

With Customed Flange



V1-FG15 V1 V2 V4 V4-FG5

Special Material



V6S-I SS Stainless Steel Outside V2-I Chromium Plated V16-I Chromium Plated

Double Shaft



VA1 V2-L V4-NDS V6-LDS V8-LDSHCV

Dedicated to Mixers



V2-M V2-LM V4-M V4-LM

We can customise air motors.



AIR GEARMOTORS

For applications where precise and variable turning power and speed is a requirement. Examples are bolt tensioning equipment or rock drilling rigs, precise lifting, lowering, traversing or turning. Unlike electric gearmotors, no chance of burn-out nor heat buildup with TONSON Air Motors. Direction of rotation is instantly reversible.

Precise Turning Power, High Torque Capacity

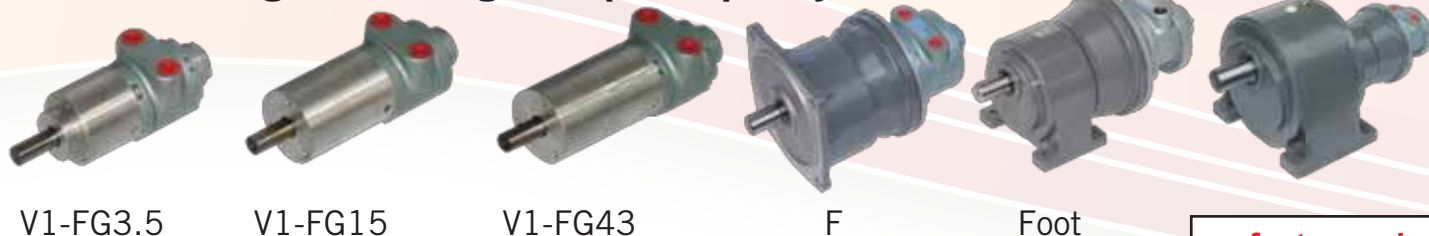

refer to gearbox division for full range gearboxes.

BRAKES

For applications where positive braking is a requirement, a range of caliper brakes is offered. These are designed to withstand full stall torque of the air motor. The brake consists of two spring supplied shoes pressed against a central hub. The shoes are released by applying air pressure to the cylinder/piston assembly. The brake torque can be carried by adjustment of two spring adjusters but it is normally set so that a pilot pressure of 4 bars (60 PSI) will fully release it.

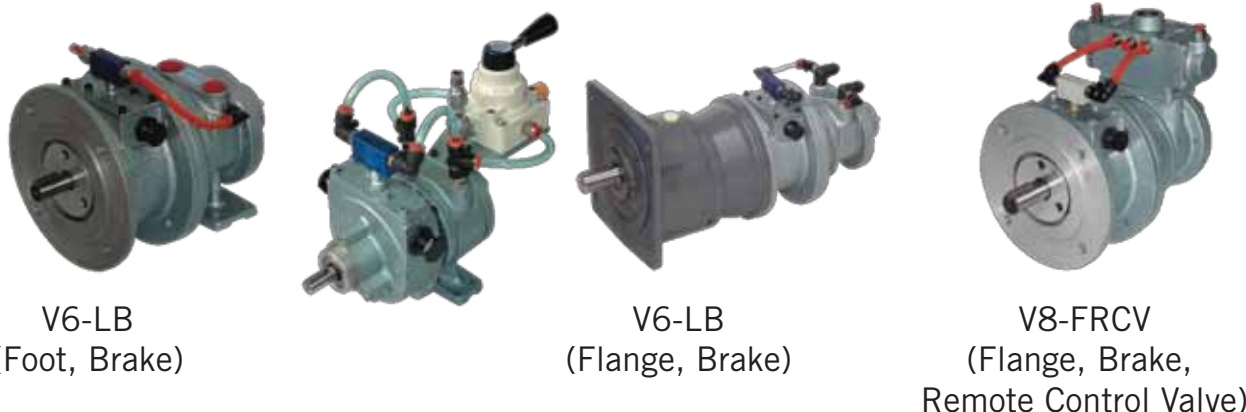

How to Order

V6 - F B G10 RCV

Motor	Mounting	Brake Option		Reducer Option				Valve Option	
V1	F Face/Hub	Blank	No Brake	Blank	No Reducer			Blank	No Valve
VA1	L Foot	B	Brake	G3	1/3	G30	1/30	HCV	Hand Control Valve
V2	B Butterfly			G5	1/5	G40	1/40	RCV	Remote Control Valve
V4	N NEMA			G10	1/10	G60	1/60		
V6	I IEC			G15	1/15	G80	1/80		
V8				G20	1/20	G100	1/100		
V16									

*Other Gearbox ratios / variations are available contact us for quote.

AIR MOTOR ACCESSORIES

Control Vales



HV1 Mini Reverse Control

HV2 Reverse Control

HV3 Reverse Control

HV4 Reverse Control

Pressure Gauge

Air Regulator

APPLICATION

Model	Vane Air Motor							
	VA1	V1	V2	V4	V6	V8	V16	
HV1 Mini (1/4")	●	●	●	●				
HV2(1/4")	●	●	●	●				
HV3(1/2")					●	●		
HV4(1")							●	
HCV1(RCV1)1/2"					★	★		
HCV2(RCV2)3/4"								
HCV3(RCV3)1"							●	
HCV4(RCV4)1-1/4"							★	
HCV5(RCV5)1-1/2"								
HCV6(RCV6)2"								

● Standard

★ Better Performance

Silencer



Model	SC2	TC1	TC2S	TC3	TC4	MF1	MF3	MF5	MF7	MF9	MF11	NM1	NM2	NM3	SM1	SM2	SP1	SP2	SP2L	SP3	SP4	PL1	PL2	PL3	PL4	PL5	PL6
Caliber(PT)	2"	1"	1-1/2"	1-1/2"	2"	3/8"	1/2"	3/4"	1"	1-1/2"	2"	1/8"	1/4"	1/2"	1/4"	1/2"	1/8"	1/4"	1/4"	3/8"	1/2"	1/8"	1/4"	3/8"	1/2"	3/4"	1"
Dia. O	86	100	70	100	100	80	90	100	112	132	150	48	76	78	40.5	65	16	16	20	26	28	12	19	20	24	40	49
Height mm	256	202	164	217	211	129	147	171	195	259	312	48	58	107	50	80	34	37	62	67	70	30	42	57	55	113	112
Material	Carbon Steel	Filter:Fiber Shell:Steel				Filter:A5052P.SPCC Shell:PC.A2011						Adsorb Active Carbon		Industrial Cotton		Forming Resin (5µm)				Filter: Plastic Particle Shell: Engineering Plastic							

FRL (Filter, Regulator, and Lubricator)



FRL1/4 Mini

FRL1/4 FRL1/2

FRL1

FRL2

FRL(1/4") Stainless Steel

Model	Vane Air Motor								Caliber	Mass (kg)
	VA1	V1	V2	V4	V6	V8	V16			
FRL1/4 Mini									1/4"	0.2
FRL1/4	●	●	●	●					1/4"	0.5
FRL1/2					●	●			1/2"	1.41
FRL1							●		1"	4.43
FRL1-1/4							★		1-1/4"	7.5
FRL2									2"	12

● Standard

★ Better Performance

Model	FRL1/4Mini	FRL1/4 & FRL1/2	SS1/4	FRL1	FRL2
Dimension(cm)	9x4.5x17.5	16x7x23.5	11.5x7x24.5	17.8x7x28	65x16x72

FRL (Filter, Regulator, and Lubricator) are recommend to improve air motor performance and provide longer life.

DIMENSIONS V1 AND VA1 SERIES

V1-F
Face

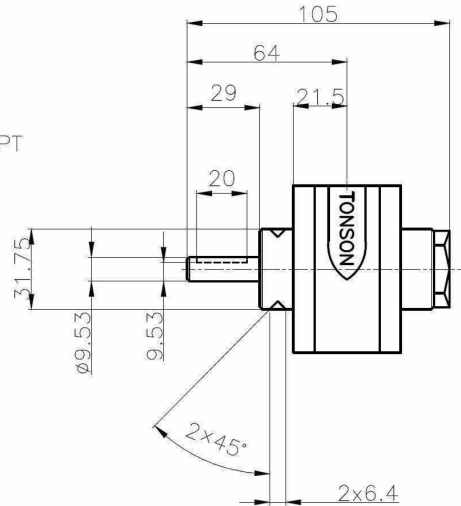
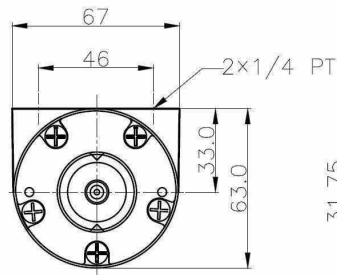

1-L
Foot

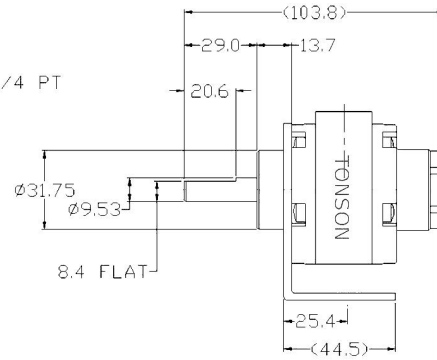
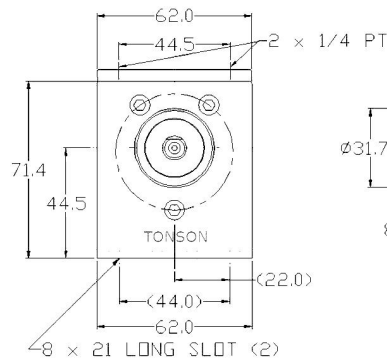

VA1-F
Face

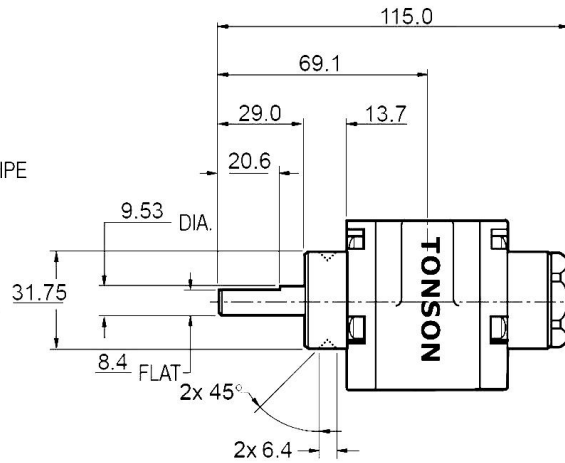
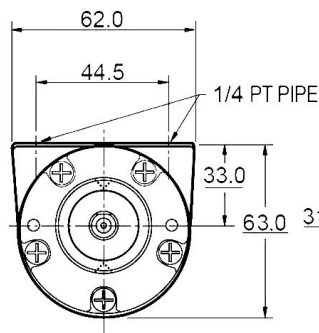

1-L
Foot

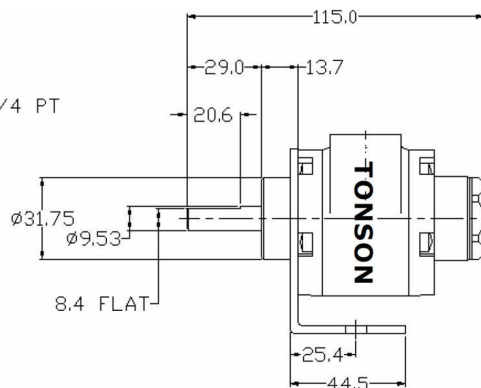
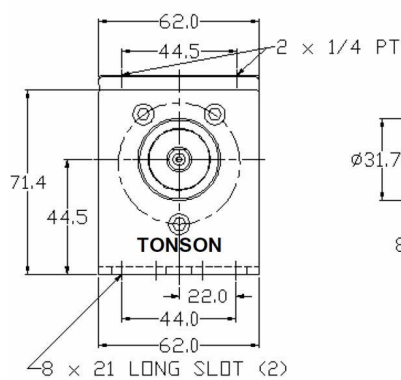

PERFORMANCE GRAPHS V1 SERIES

Horsepower vs. Speed

V1 Series
Vane Air Motors

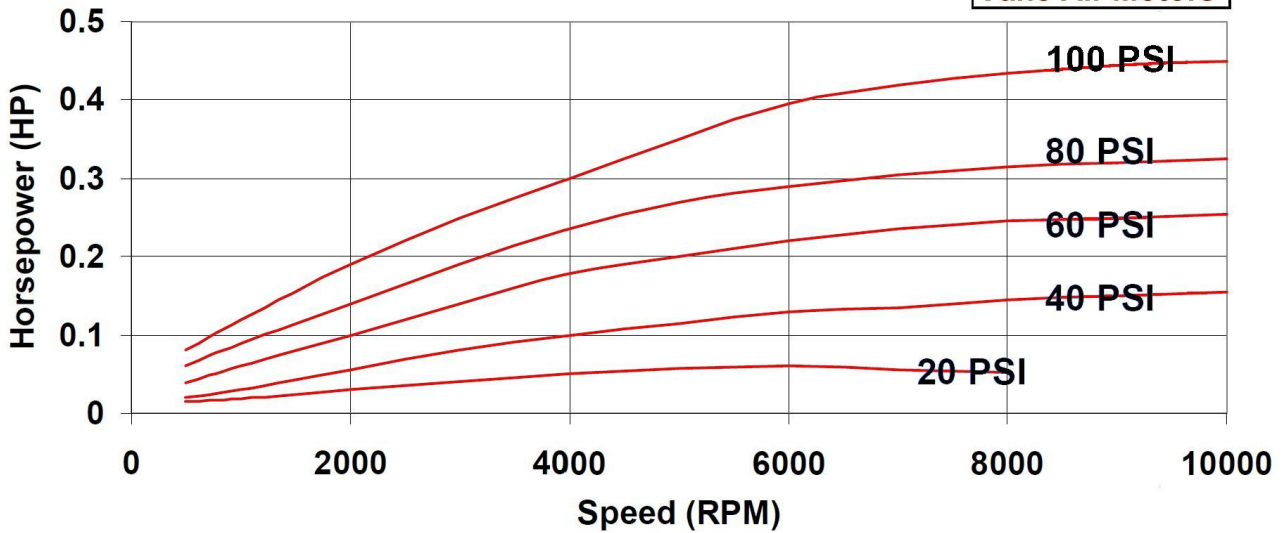

Torque vs. Speed

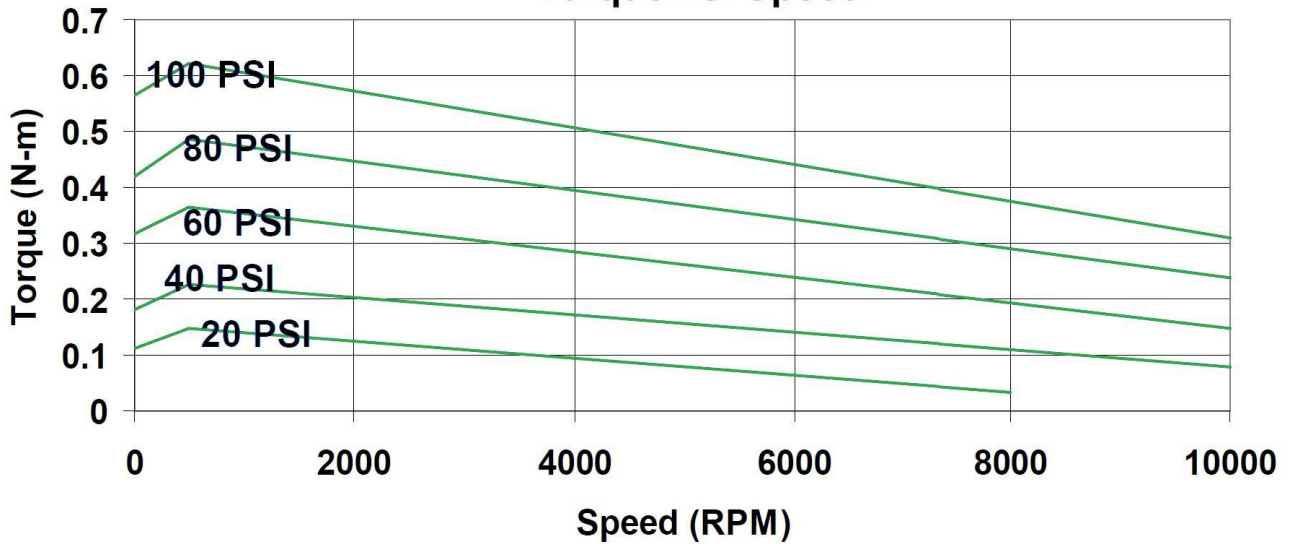

Air Consumption vs. Speed

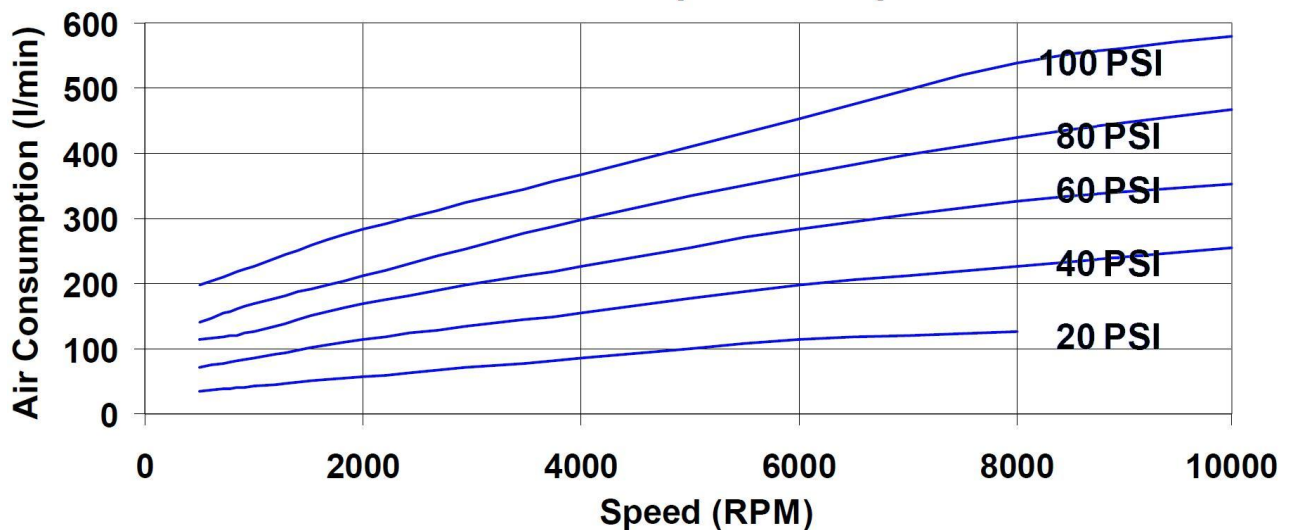

PERFORMANCE GRAPHS VA1 SERIES

VA1 Series
Vane Air Motors

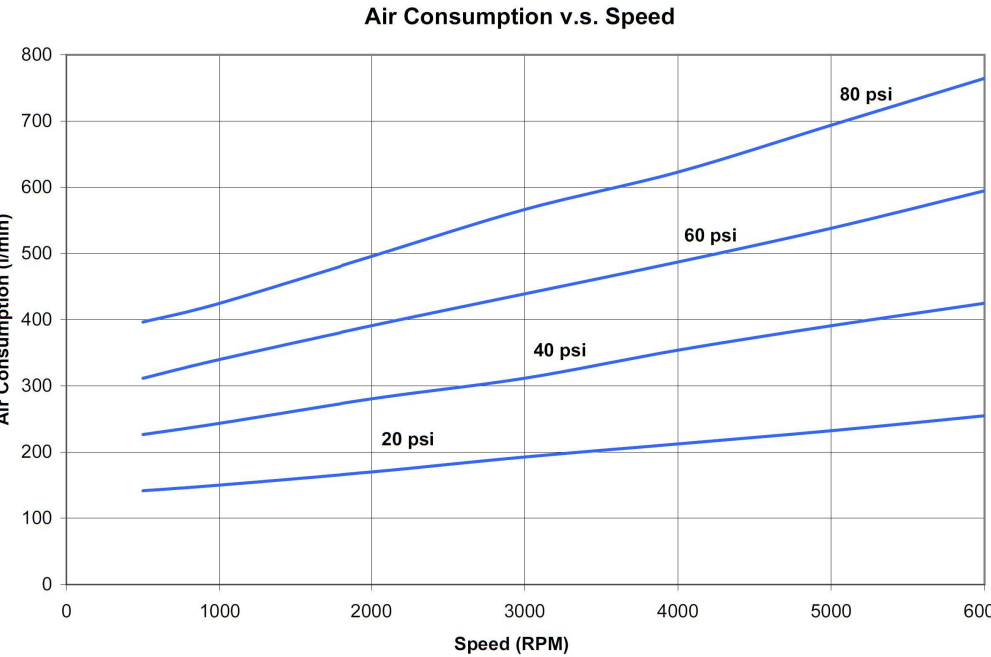
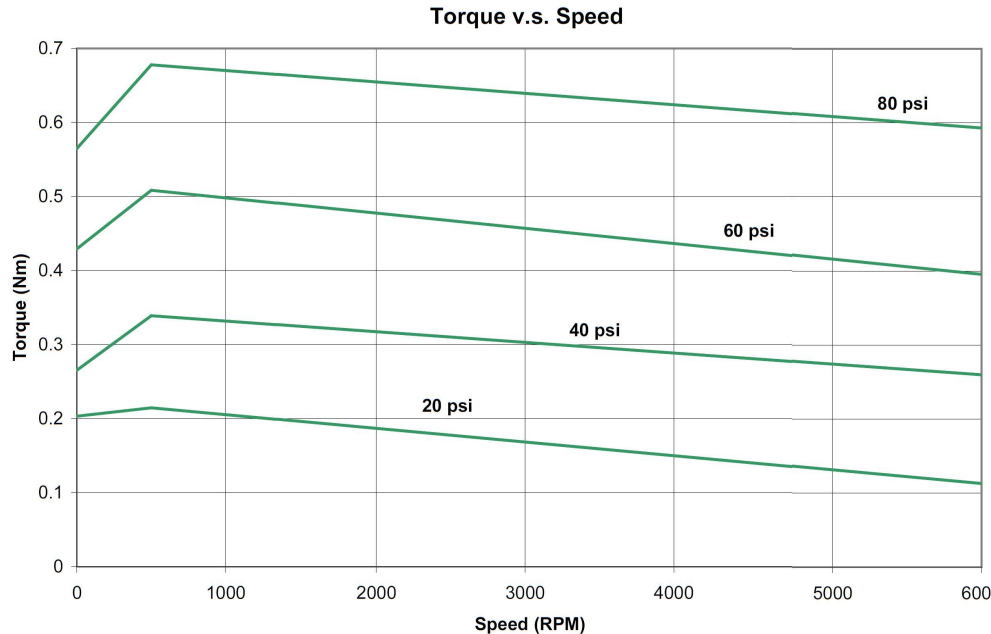
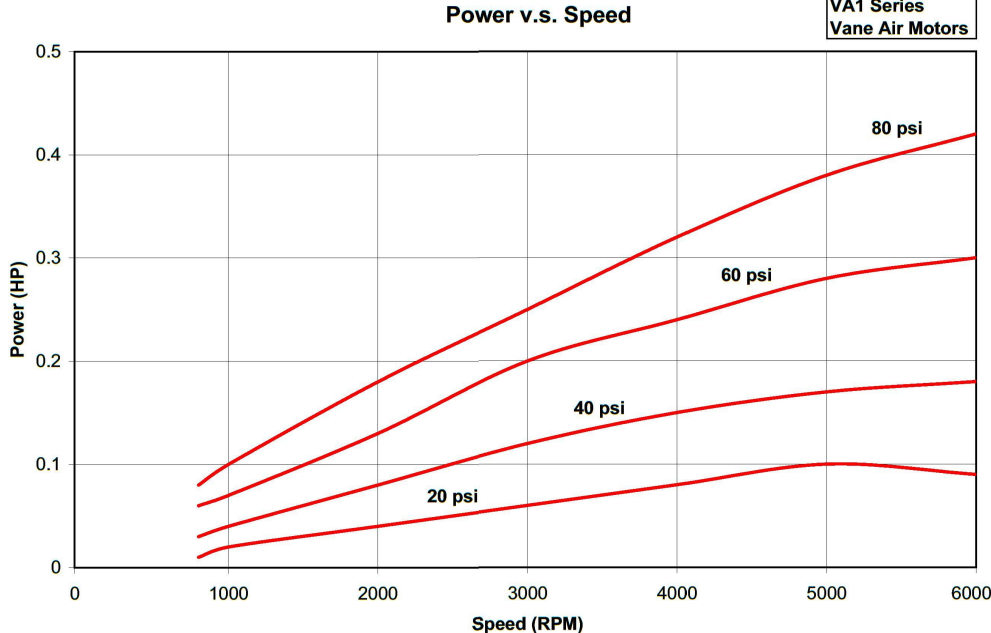

DIMENSIONS V2 SERIES

V2-B
Butterfly

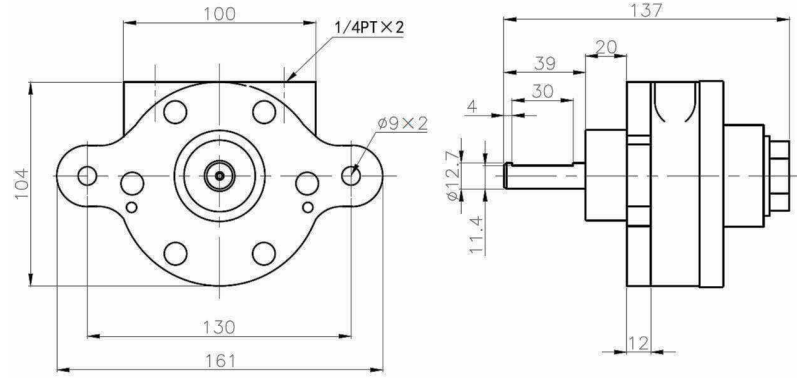

V2-F
Face

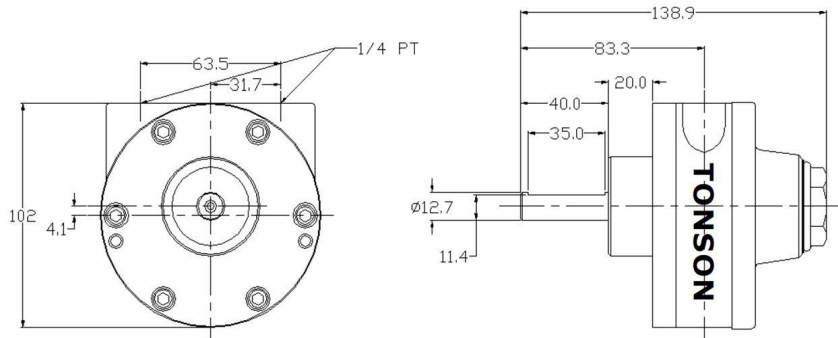

V2-L
Foot

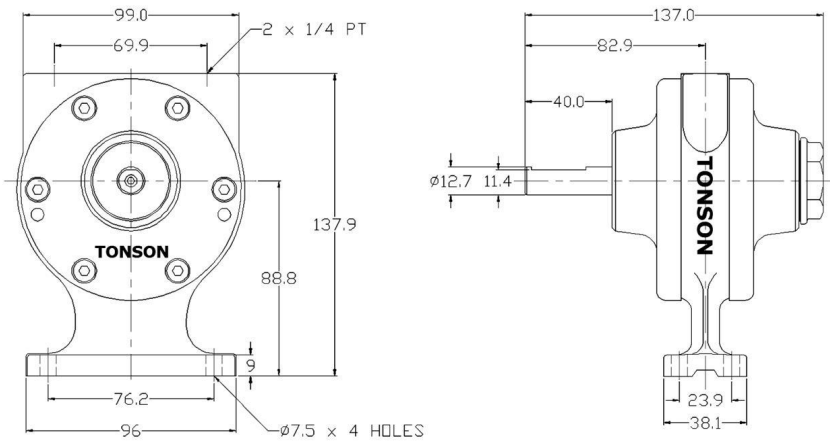

V2-N
NEMA 56C

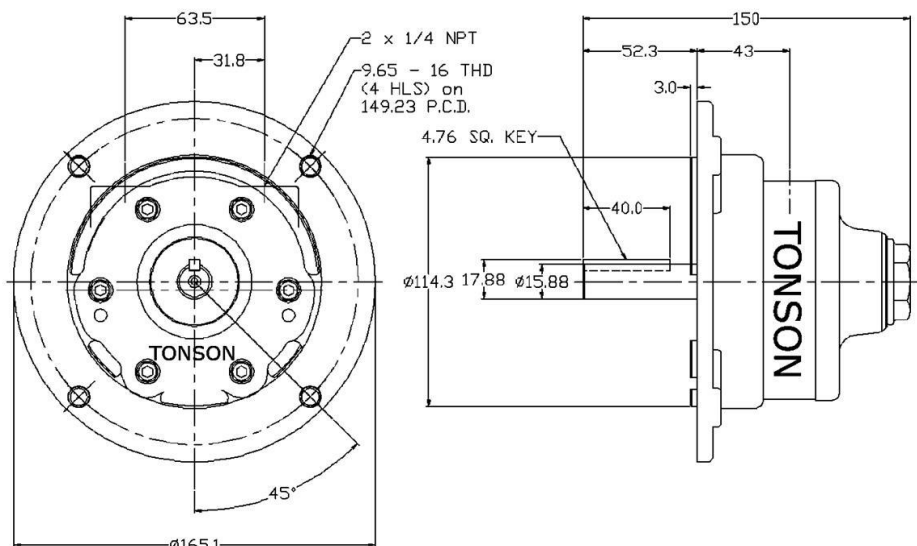

PERFORMANCE GRAPHS V2 SERIES

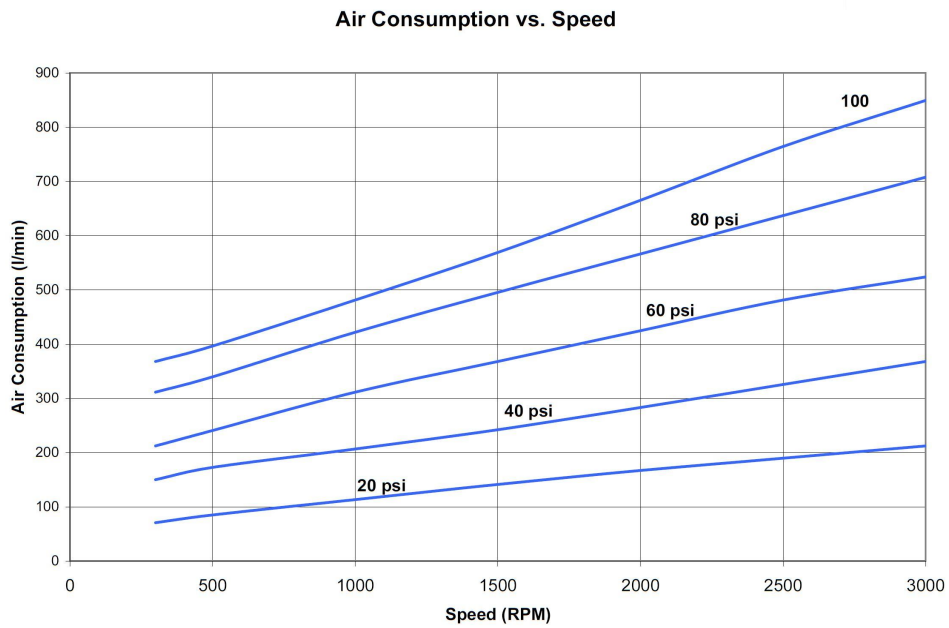
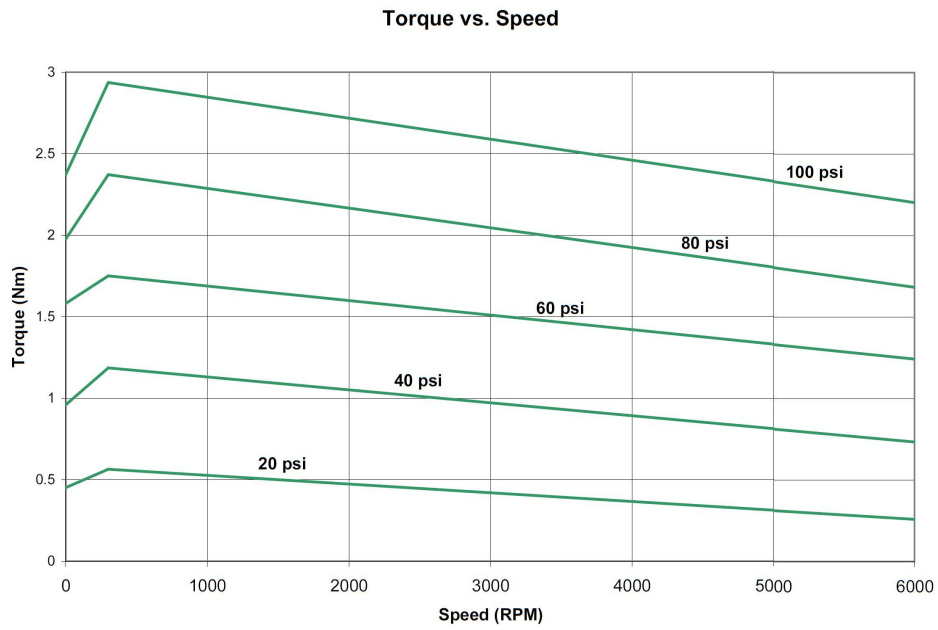
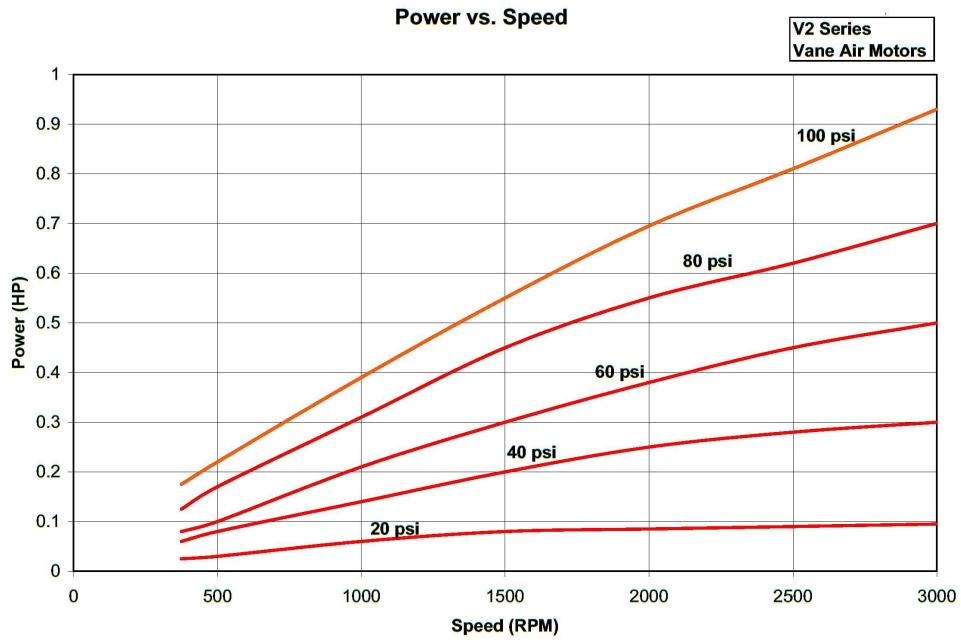

DIMENSIONS V4 SERIES

V4-F
Face

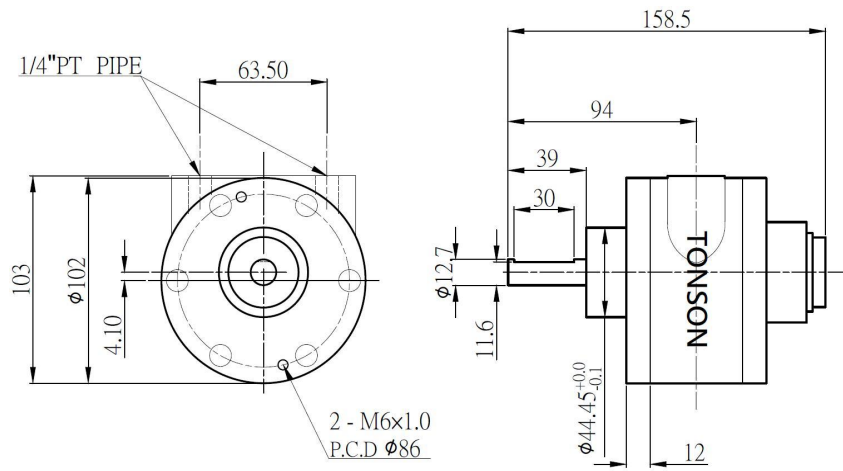

V4-I
IEC D71

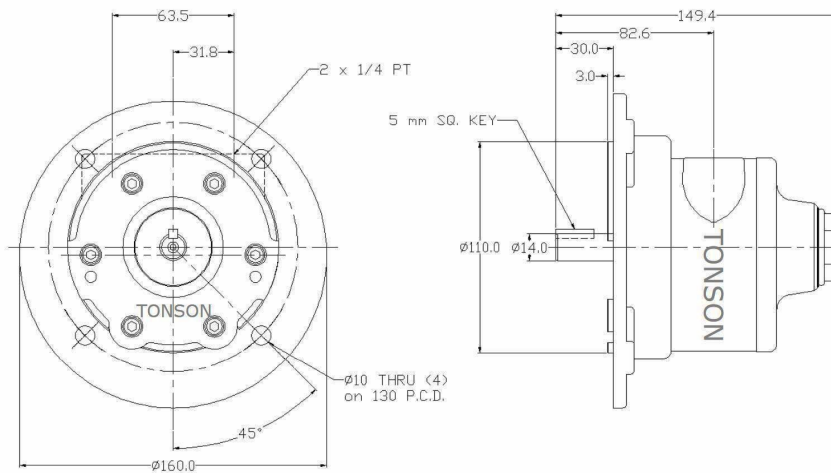

V4-L
Foot

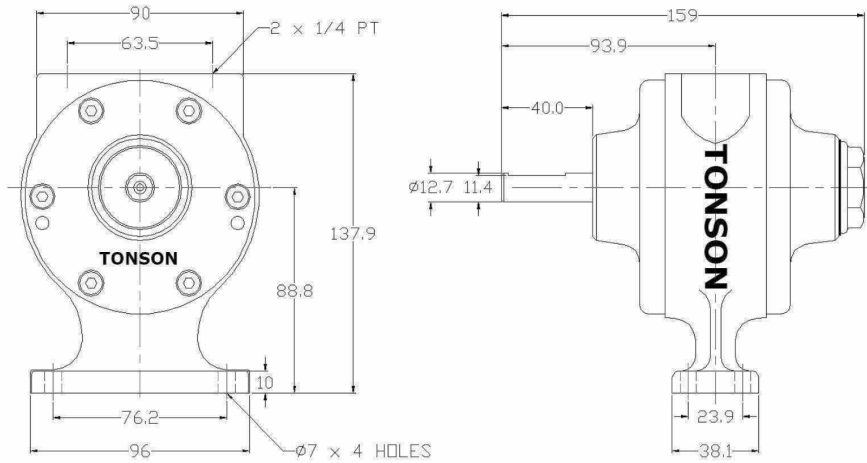

V4-N
NEMA 56C

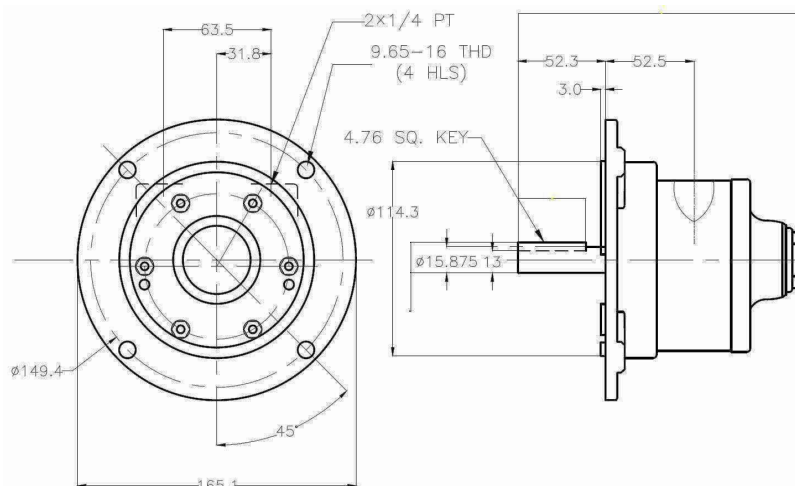

PERFORMANCE GRAPHS V4 SERIES

Power vs. Speed

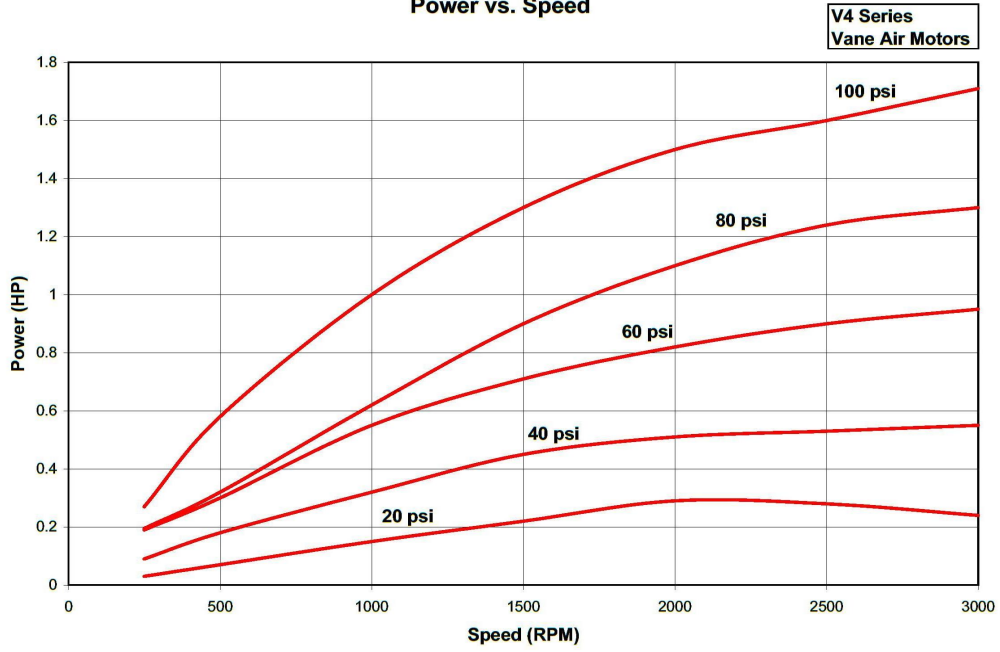

Torque vs. Speed

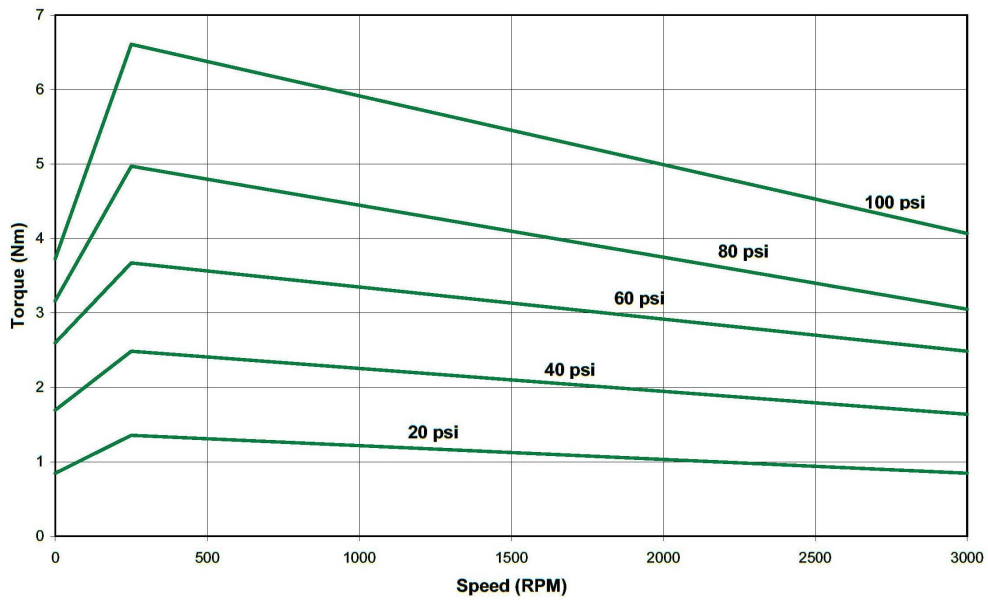

Air Consumption vs. Speed

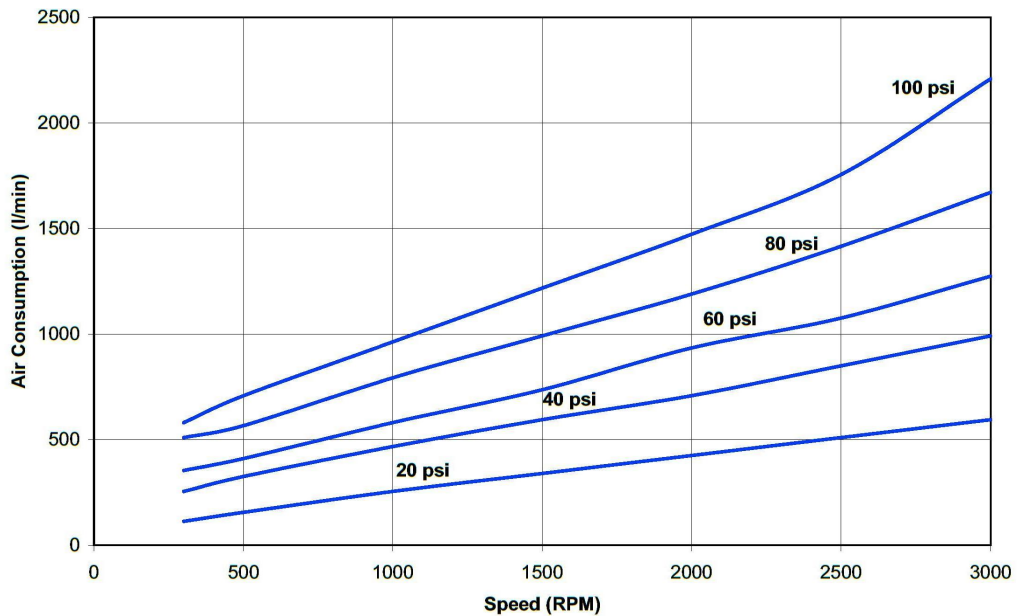

DIMENSIONS V6 SERIES

V6-F
Face

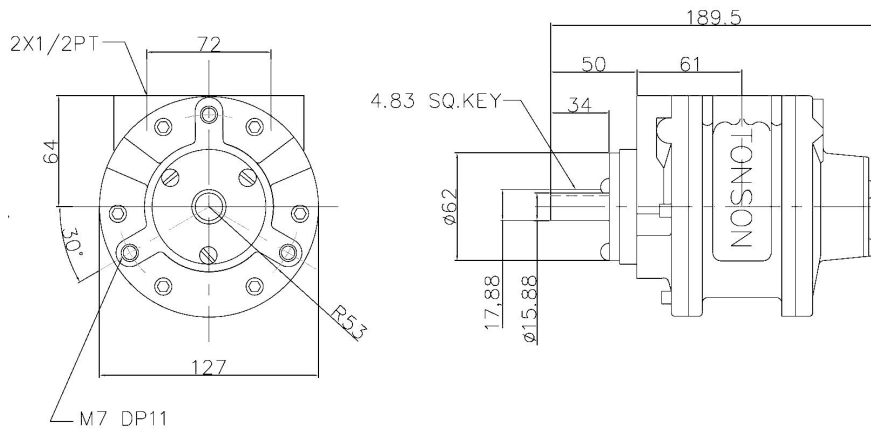

V6-I
IEC D80

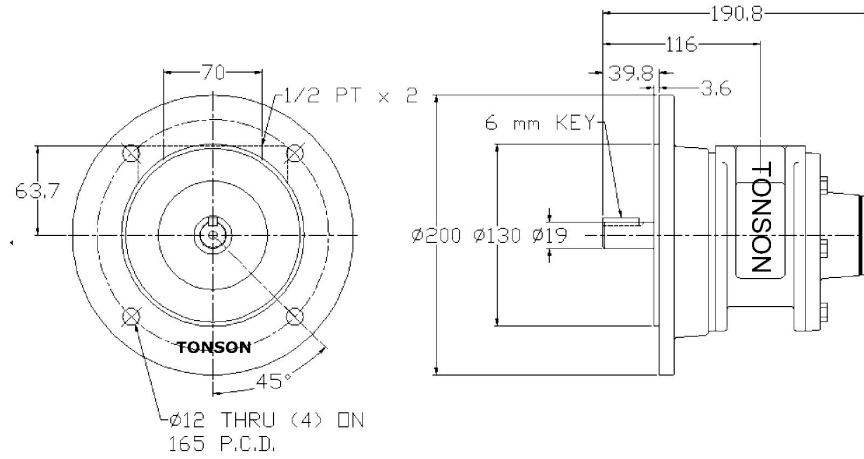

V6-L
Foot

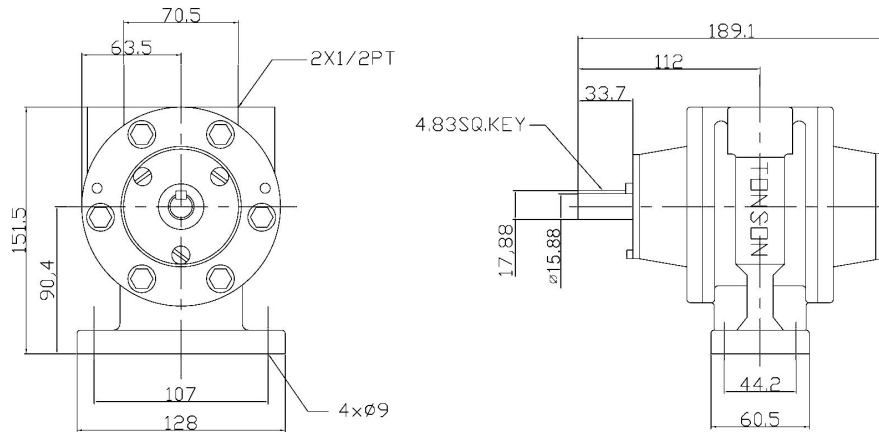

V6-N
NEMA 56C

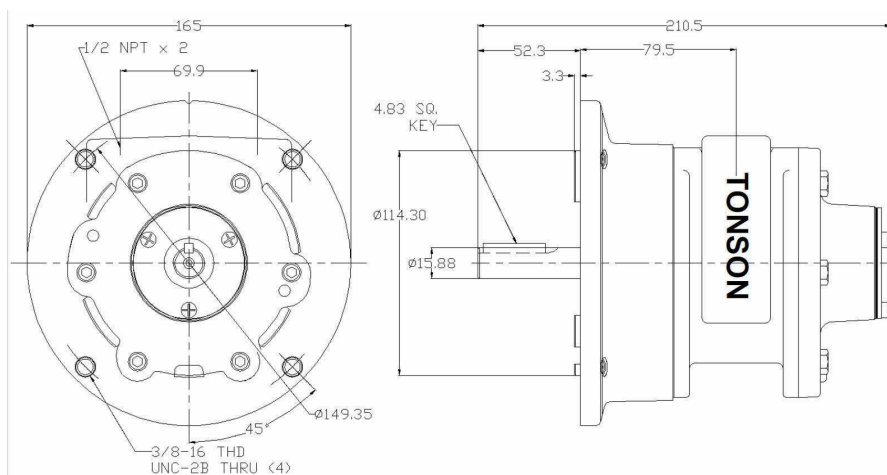

PERFORMANCE GRAPHS V6 SERIES

V6 Series
Vane Air Motors

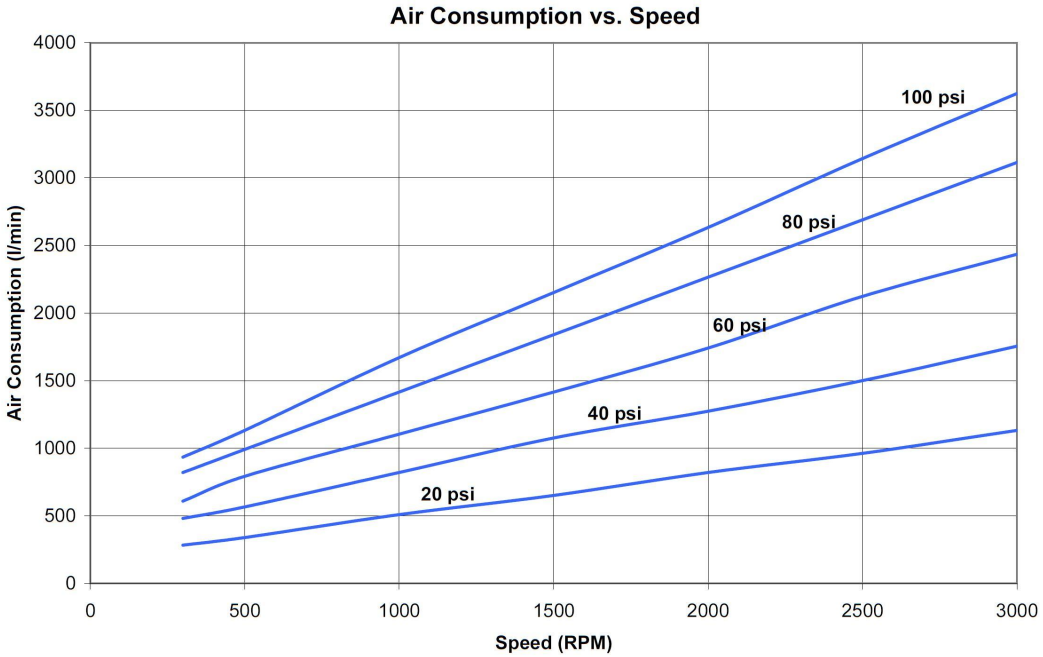
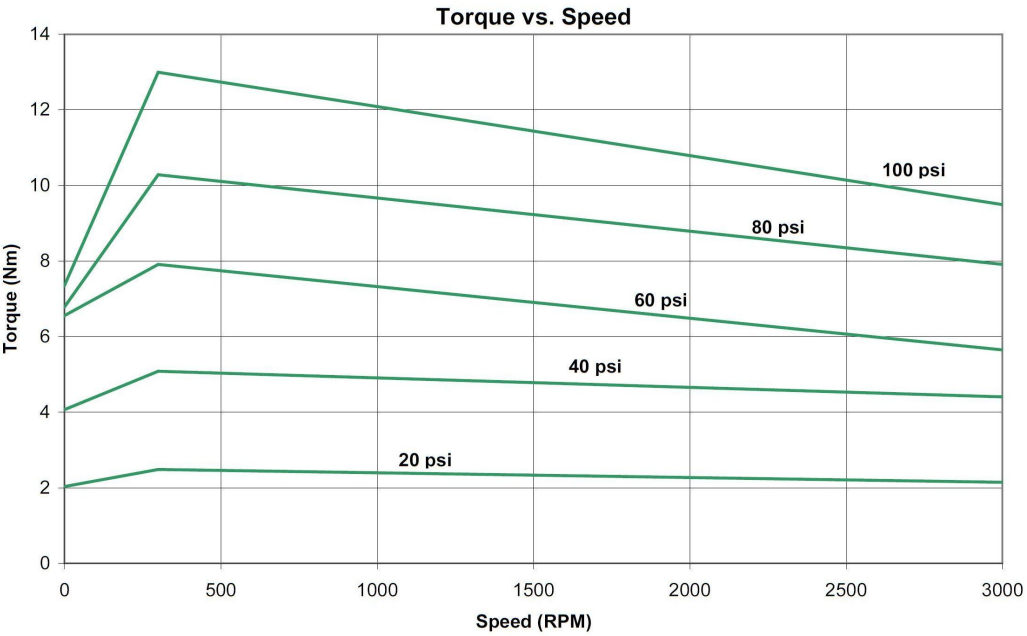
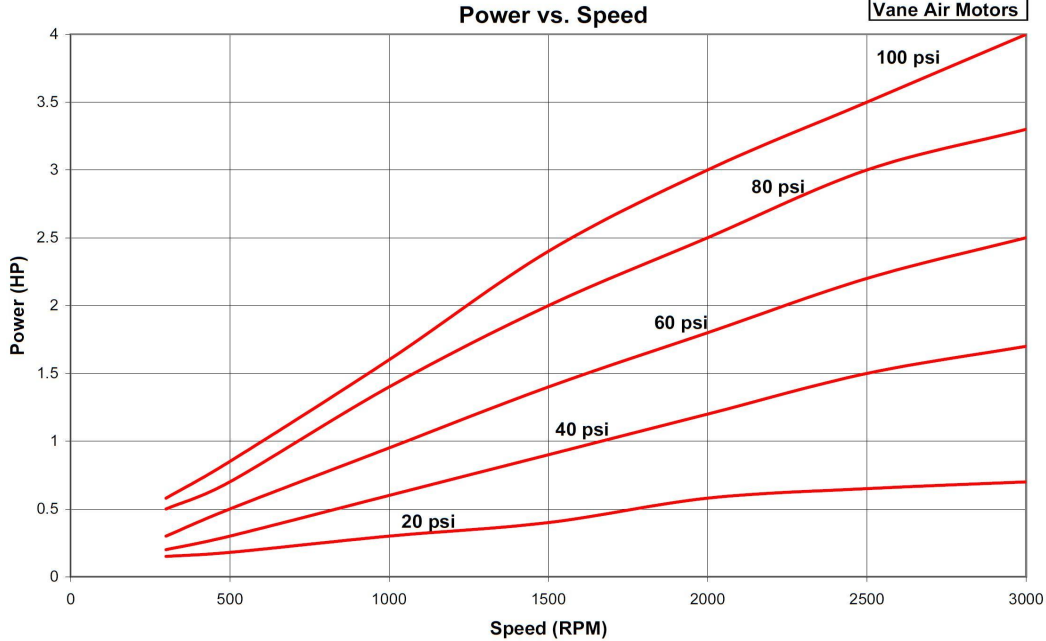

DIMENSIONS V8 SERIES

V8-F
Face

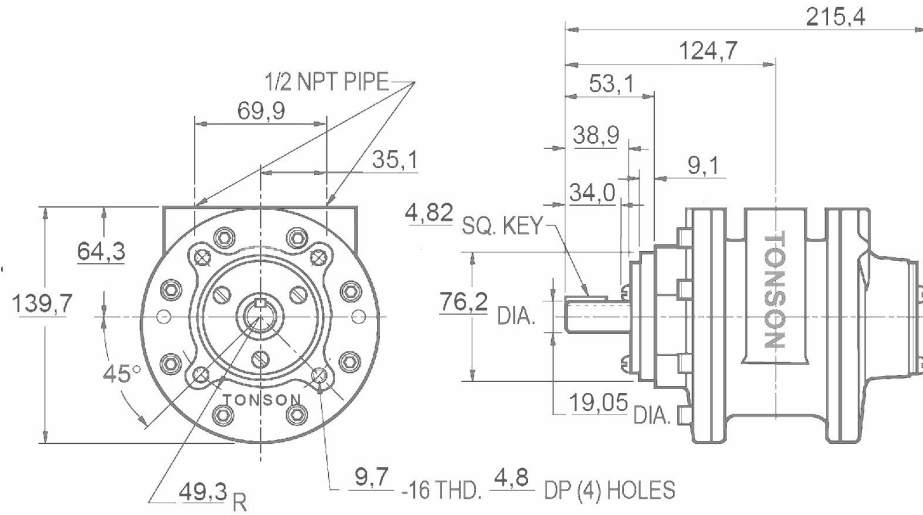

V8-I
IEC D90

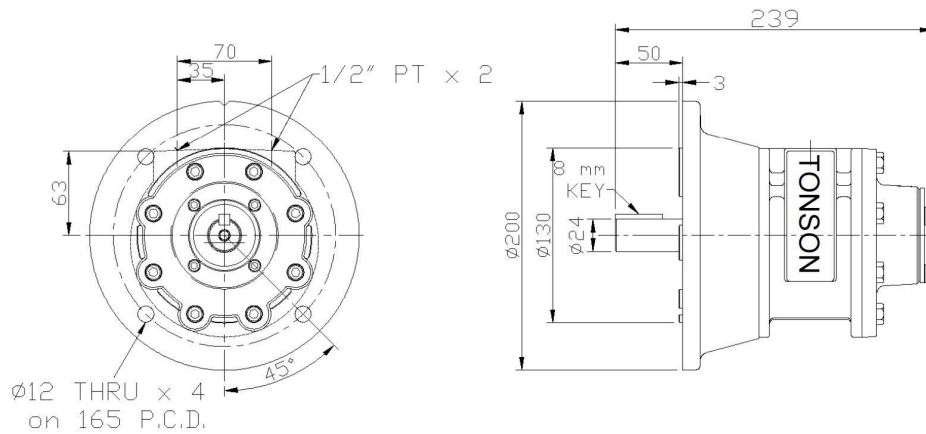

V8-L
Foot

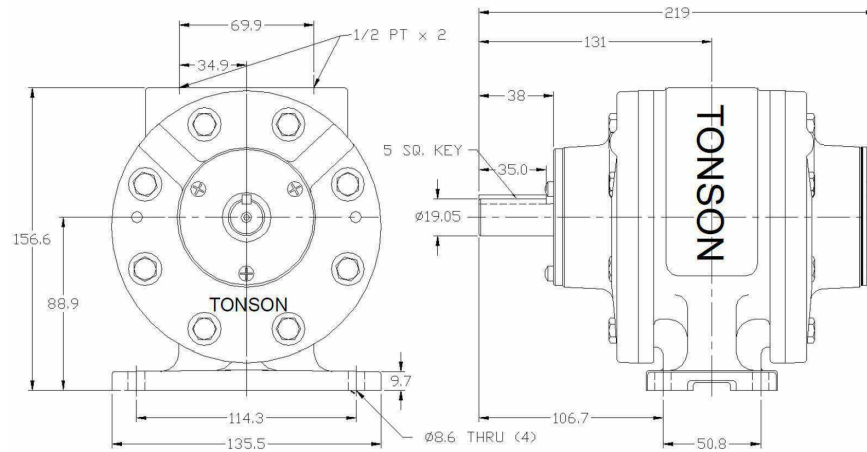

V8-N
NEMA 145TC

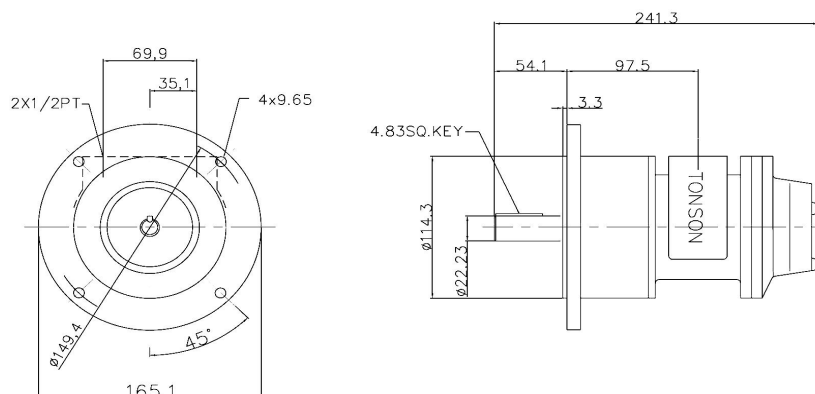

PERFORMANCE GRAPHS V8 SERIES

V8 Series
Vane Air Motors

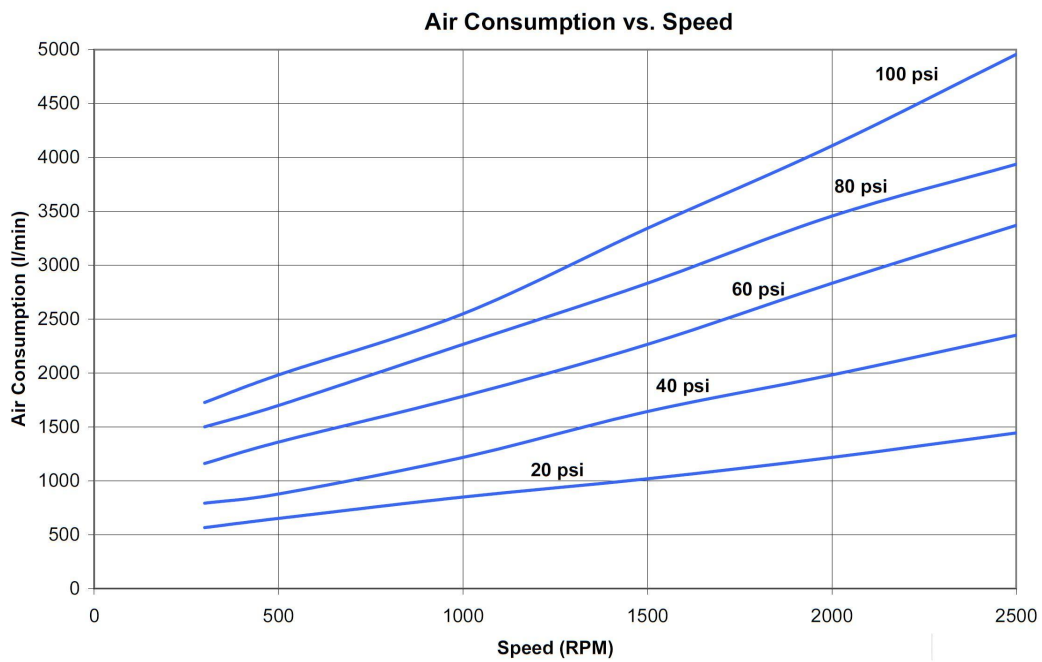
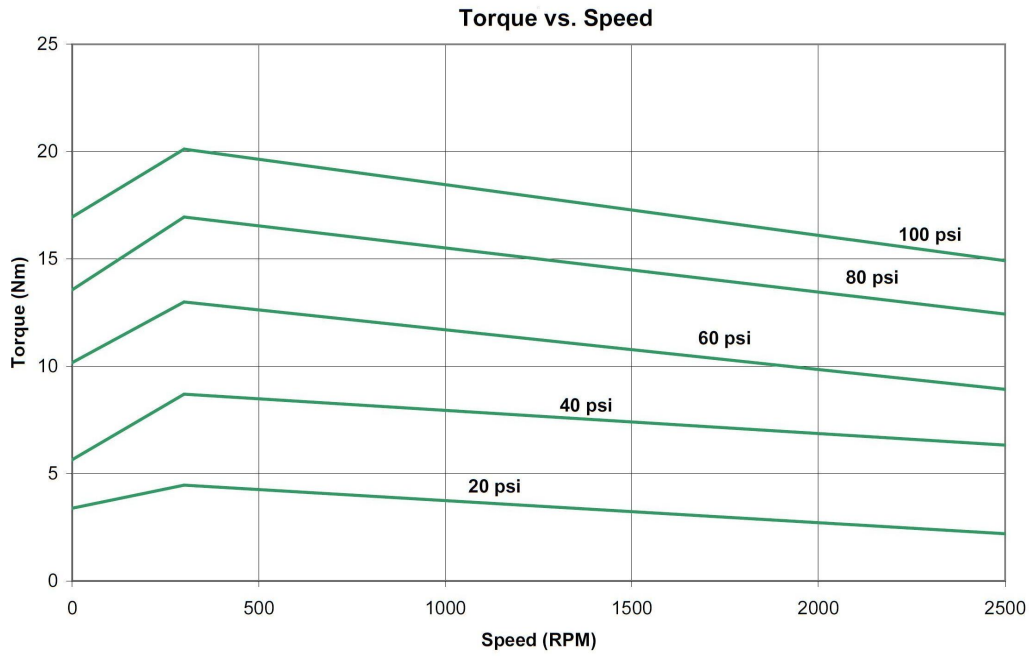
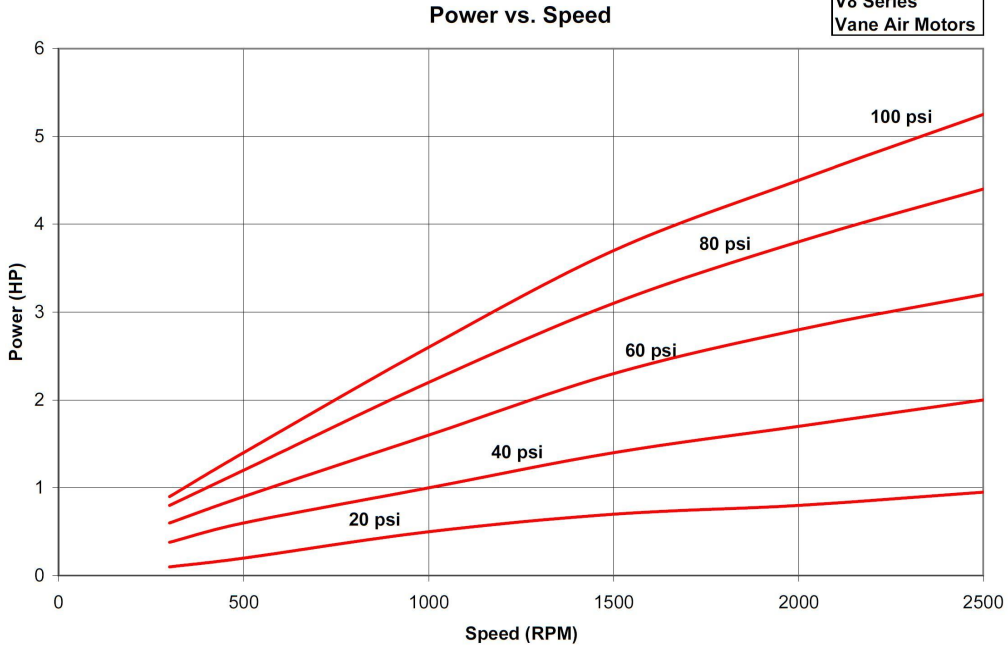

DIMENSIONS V16 SERIES

V16-F
Face

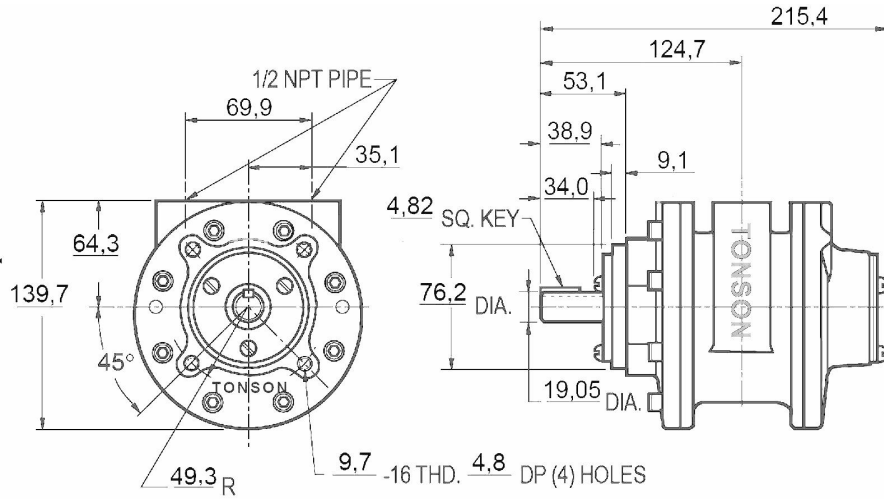

V16-I
IEC D100

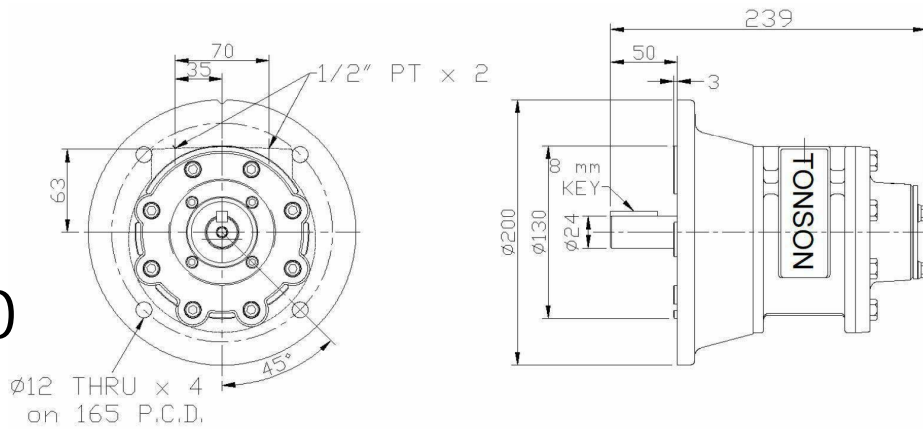

V16-L
Foot

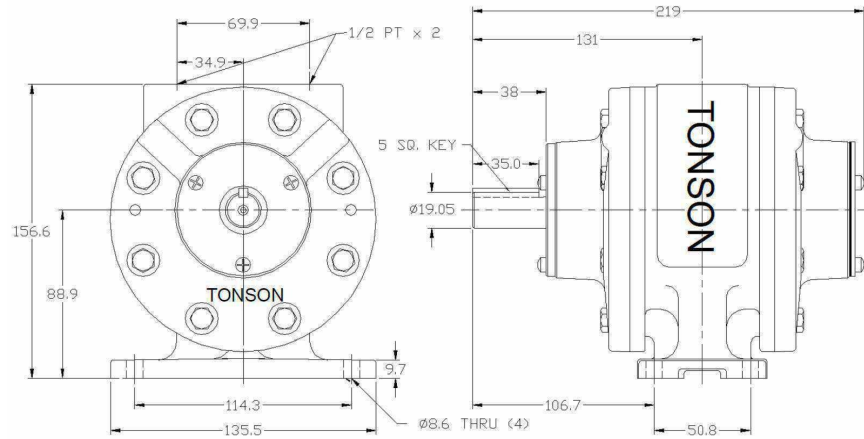

V16-N
NEMA 145TC

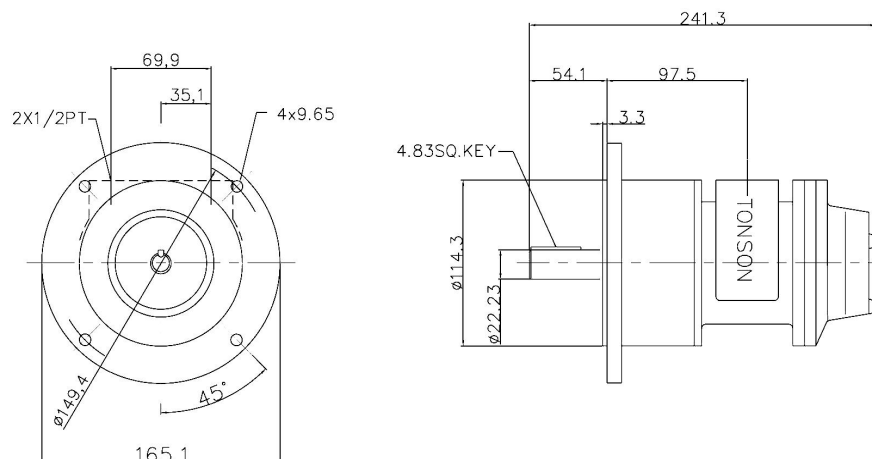

PERFORMANCE GRAPHS V16 SERIES

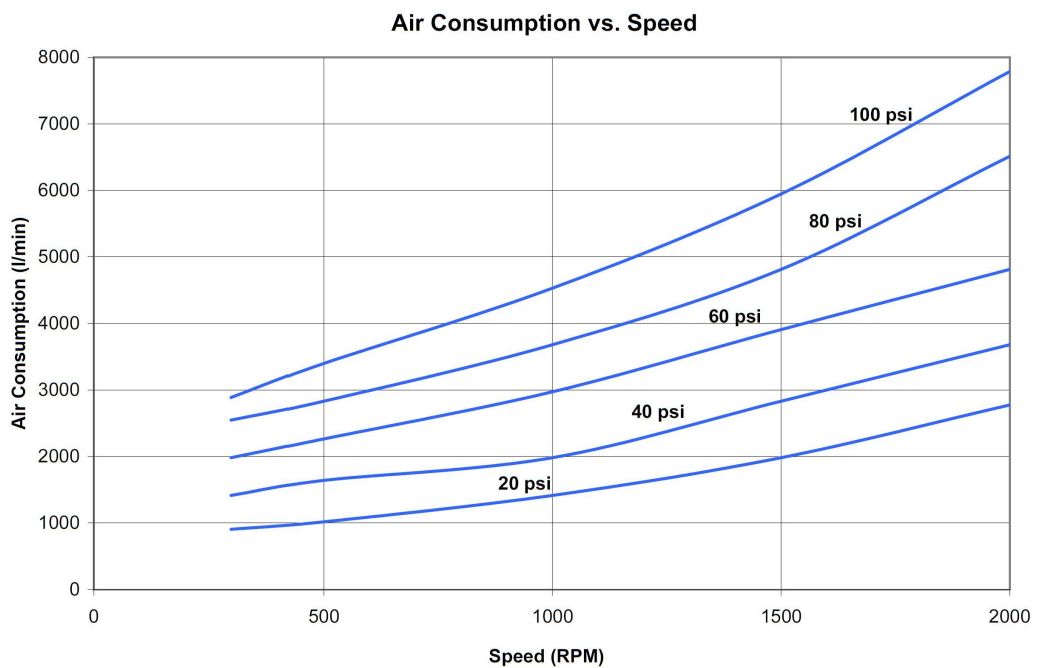
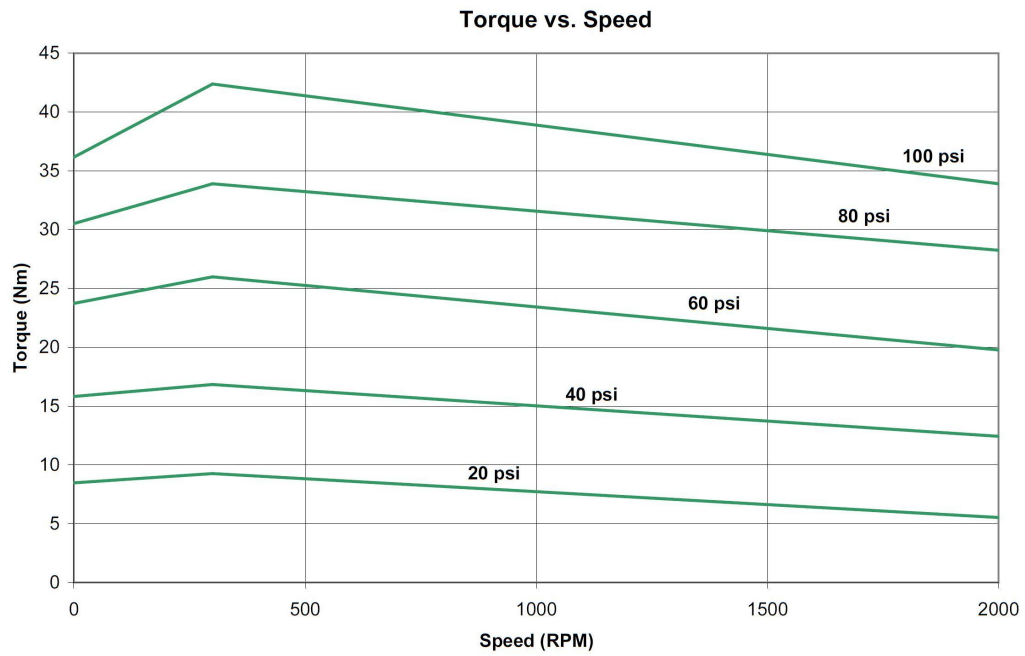
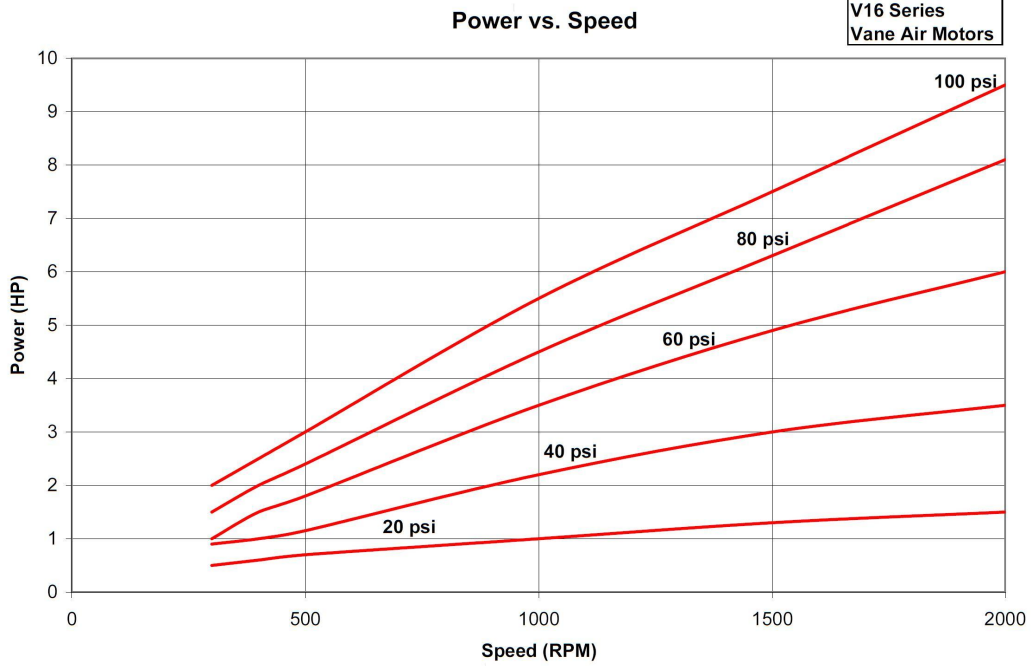

SAMT[®]



Specialised Air Motors and Transmission

TONSON[®]

New South Wales

HEAD OFFICE

Unit 19/5 Lyn Parade

Prestons NSW 2170

Ph: (02) 9607 4100

Fax: (02) 9600 8882

Web: www.tonson-motor.com.au

Email: sales@samt.com.au